

Mediterranean, Knowledge, Culture and Heritage 3

Özlem ÇAYKENT – Luca ZAVAGNO
Editors

PEOPLE AND GOODS ON THE MOVE

Merchants, Networks and Communication Routes
in the Medieval and Early Modern Mediterranean



ISBN online: 978-88-99662-02-8



Mediterranean, Knowledge, Culture and Heritage 3

Mediterranean, Knowledge, Culture and Heritage

Book Series edited by

Giuseppe D'Angelo and Emiliana Mangone

The Book Series, published in electronic open access, shall be a permanent platform of discussion and comparison, experimentation and dissemination, promoting the achievement of methodological action-research goals, in order to enforce the development of the territories and of the local and European identities, starting from the cultural heritage and from the Mediterranean Area. All the research work revolves around three key topics:

Mediterranean: The knowledge and cultural values of southern Europe and the Mediterranean Area may represent the strategic elements to overcome the current crisis in Europe, to the point of becoming a stimulus for the review of policies.

Knowledge: Language, history, tradition and art have always conveyed dialogic relations and interpersonal relationships within societies, founding on otherness the peculiarities understood as knowledge development, processes, sedimentation and transformation. What becomes peculiar is the "knowledge" as the achievement of an advantage derived from the possession of unique and inimitable knowledge.

Culture and Heritage: Culture, understood as its cultural heritage, is proposed as one of the privileged areas of the "new economy". In fact, the encounter between culture and territory represents one of the most valuable opportunities for development.

Each manuscript submitted in English will be subject to double-blind peer reviewing.

Scientific Board

Ines Amorin (UP – Portugal), Paolo Buchignani (UNISTRADA – Italy), Rosaria Caldarone (UNIPA – Italy), Bernard Callebat (ICT – France), Calogero Caltagirone (LUMSA – Italy), Rossella Caruso (ISIA – Italy), John Chircop (UM – Malta), Folco Cimagalli (LUMSA – Italy), Louisa Driss Aït-Hammadouche (University of Alger3 – Algeria), Mar Gallego (UHU – Spain), Carlo Gelosi (UNISTRADA – Italy), Lea Mattarella (ABA of Naples – Italy), Blanca Miedes (UHU – Spain), Flavia Monceri (UNIMOL – Italy), Luís Nobre Pereira (UAlg – Portugal), Paul Sant Cassia (UM – Malta), Francesco Vespasiano (UNISANNIO – Italy), Grégory Woimbée (ICT – France).

Editorial Board

Mariarosaria Colucciello, Erminio Fonzo, Elvira Martini, Giuseppe Masullo, Emanuela Pece

Editorial Manager

Erminio Fonzo

Preface by the Series Editors

This book is the third issue of the ICSR Mediterranean Knowledge book series “Mediterranean, Knowledge, Culture and Heritage”. The first two focused attention respectively on the sociological implications of the recent events which retain a global impact; on the Mediterranean from the Middle Age to the Contemporary Era, delving on some topics that, for centuries, have been concerning the area analyzed in a diachronic perspective. This book focuses on the political, economic and religious aspects of the Mediterranean as a matrix of communication in the Medieval and Early Modern era.

The book results from an attentive and detailed selection of the papers presented during one of the MedWorlds Conferences (University of Salerno, 2011), but it is not only a traditional “proceedings volume”; it is rather an attempt to propose a comprehensive and diachronic approach to the problems of trans-maritime communications in the Mediterranean.

The Mediterranean Sea was called *Mare Nostrum* by the Romans, because the land washed by this sea – or the sea that bathed this land – was indeed almost entirely part of the Empire. “The Mediterranean is not just a geographical concept. Its borders are not defined neither in terms of space nor in time” (Matvejevic, 2013: 18), nevertheless, the Mediterranean area witnessed the development and diffusion not only of the Roman civilization, but also of the greatest civilizations, religions, and arts that stretch far beyond the fall of the Roman Empire and long before its birth (Mangone, 2015).

The Medieval and Early Modern Eras, analyzed in this book, were characterized by complex relations between Christians and Muslims; Henri Pirenne (1937) famously stated that, after the conquest of the VII-IX centuries, the Mediterranean became an “Islamic lake”, for the followers of Muhammad conquered almost all the territories along its shores and *de facto* ruled over the *Mare Nostrum*. However, the Mediterranean was also the place where the new Arab-Muslim culture and Christian Europe began to interact. Indeed, the bloody experience of the Crusades and the continuous fights between Christians and Muslims did not prevent fruitful exchanges, not only of goods, but also among peoples and cultures. In this way, places such as the Iberian peninsula and the Sicily saw the development of flourishing civilizations, built on the interaction of different cultures.

The book offers an overview of the documentary, literary and even material (archaeology) sources that are pertinent draw a chronologically extensive and coher-

ent picture of the people (and goods) which crisscrossed the *Mare Nostrum* from the Medieval to the late Modern period; thus, by implication, it also assumes to include the meanings that are variously expressed by the main studies of the Mediterranean and related contexts (from Braudel to Horden-Purcell and Abulafia). In this light, the array of papers included in the volume are meant to be integrated, in the sense that they make explicit connections between the elements of transdisciplinary studies (from history to art, from anthropology to archaeology, from literature to geography) embracing those global realities that help to shape interests and materials of high interest to both scholars and the general audience at large. On the basis of this assertion, the book aims to discuss different topics with a transdisciplinary approach (Piaget, 1972): “It is more and more necessary, indeed, to build new synergies and new epistemological relations among different, but complementary, sciences” (D'Angelo & Mangone, 2016: 4).

By focusing mainly on the “faces” which traveled, the book reveals a penchant for micro-history and for the stories of those who lived at the grassroots of the Mediterranean; slaves, pilots, intellectuals, teachers, merchants and diplomats emerges here as knots of a complex, transforming and resilient web of intercultural communication and cross-cultural encounters which reminds us that - as Horden and Purcell stated (2000) - defining the uniqueness of the Great Sea in its *long durèe* means exalting the importance of connectivity.

Fisciano, Italy
December 2016

Giuseppe D'Angelo
Emiliana Mangone

References

- D'Angelo, G. & Mangone, E. (2016). Beyond the Disciplinary Borders: A New Challenge. *Journal of Mediterranean Knowledge-JMK*, 1(1), pp. 3-9.
- Horden, P. & Purcell, N. (2000). *The Corrupting Sea. A Study of Mediterranean History*. Oxford: Wiley-Blackwell.
- Mangone, E. (2015). *The Mediterranean Knowledge for the Future of Europe*. Cava de' Tirreni: AreaBlu Edizioni.
- Matvejević, P. (2013). *Breviario Mediterraneo*. Milano: Garzanti.
- Piaget J. (1972), *L'épistémologie des relations interdisciplinaires*, in OCDE, ed., *L'interdisciplinarité: problèmes d'enseignement et de recherche dans les universités*, OCDE, Paris. Testo disponibile al sito: http://www.fondationjeanpiaget.ch/fjp/site/textes/VE/jp72_epist_relats_interdis.pdf, consultato il 20/06/2015.
- Pirenne, H. (1937). *Mahomet et Charlemagne*. Paris: Alcan.

ÖZLEM ÇAYKENT – LUCA ZAVAGNO

Editors

PEOPLE AND GOODS ON THE MOVE

**Merchants, Networks and Communication
Routes in the Medieval and Early Modern
Mediterranean**



MEDITERRANEAN KNOWLEDGE
International Centre for Studies & Research

The volume is available on the website:

<http://www.mediterraneanknowledge.org/publications/index.php/bookseries>

ISBN online: 978-88-99662-02-8

How to cite this volume:

Çaykent, Ö. & Zavagno, L. (Eds.). (2016). *People and Goods on the Move. Merchants, Networks and Communication Routes in the Medieval and early Modern Mediterranean*. Fisciano, Italy: ICSR Mediterranean Knowledge. DOI: 10.26409/2016MKbook03

On the cover: Globe by Juan de la Cosa (1500).

© ICSR Mediterranean Knowledge 2016

Via Giovanni Paolo II n. 132, 84084 Fisciano, Italy



Peer reviewed contents

Contents

<i>Introduction. A Mediterranean of traveling faces and ideas.</i> Özlem Çaykent and Luca Zavagno	pag. 1
--	--------

Part I – Medieval Mediterranean

<i>Slavery and the Seventh Century Caesura</i> T.J. MacMaster	» 9
--	-----

<i>A Kingdom of Silk: The Genoese as Artisans, Merchants, Bankers, 1450-1650</i> Cèline Dauverd	» 41
--	------

<i>Relations, Politics and Economic Choices in the Mediterranean: The Kingdom of Naples and Tunisia between the Thirteenth and the Fourteenth centuries</i> Mariasaria Salerno	» 65
---	------

Part II – Modern Mediterranean

<i>Procuratorial Networks: Reconstructing Communication in the Early Modern Adriatic</i> Stephan Sander-Faes	» 79
---	------

<i>The Construction of a Professional Minority. 'Istrian Pilots' in Early Modern Venice (15th-18th Centuries)</i> Alessandro Buono	» 93
---	------

*Intangible Cargo / Elusive Itineraries. Traveling Intellectuals,
Experts, Advisers and Artist at Byzantine, Ottoman and Renaissance
courts*

Slobodan Dan Paich » 111

Dutch Navigation in Sicily (First Half of the Seventeenth Century)

Federico Rigamonti » 143

Editors and Contributors

About the editors

Luca Zavagno graduated from the University of Venice (2002); he obtained his Ph.D. (2007) at the University of Birmingham with a dissertation on the society, economics and politics of Byzantine cities in the early middle ages. He is currently Assistant Professor in the Department of History at Bilkent University. Dr. Zavagno is the author of many articles on the early Medieval Mediterranean, as well as two monographs: *Cities in Transition: Urbanism in Byzantium Between Late Antiquity and the Early Middle Ages* (British Archaeological Reports-International Series, 2009) and *Cyprus between Late Antiquity and the Early Middle Ages. An Island in Transition* (Routledge, forthcoming 2017). He co-authored (with Özlem Caykent) the edited volume *Islands of Eastern Mediterranean. A History of Cross Cultural Encounters* (I.B. Tauris, 2014). He is also the co-organizer of the Conference of the Mediterranean Worlds (www.medworlds.org), Associate Scholar of the Mediterranean Seminar (<http://humweb.ucsc.edu/mediterraneanseminar/>) and former Visiting professor in Byzantine Art History at the University of Venice.
e-mail: luca.zavagno@gmail.com

Özlem Caykent is an assistant professor at History Department at 29 Mayıs University. She received her BA in English Language and Literature from Boğaziçi University and her MA and PhD in History from Bilkent University. Her research interests rest on Intellectual history ranging from Scottish Enlightenment, Modernity, to Global historiography. She is one of the founders of the MedWorlds Conferences. Some examples of her published work include co-edited book *Islands of the Eastern Mediterranean*, and articles on the popular conceptions of Enlightenment ideas, childhood memories from the conflict-era of Cyprus.
e-mail: caykent@gmail.com

Contributors

Thomas MacMaster is Adjunct Professor in the Department of History at Morehouse College where he teaches. He is the author of many contribution on the Islamic Levant and co-author of the volume *The Long Seventh Century. Continuity and Discontinuity in the Age of Transition* (Peter Lang, 2015). *Celine Dauverd* is Associate Professor of History at the University of Colorado Boulder. She specializes in the cultural history of Golden age Spain and Renaissance Italy. Her first book is entitled *Imperial Ambition in the early modern Mediterranean: Genoese merchants and the Spanish crown* (Cambridge NY 2015). Her second book deals with viceroys ceremonies and the principle of good government in Renaissance Naples. Her most recent book project investigates the concept of dhimma through the relationship between Maghrebi sultans and the Italian communities in the early modern Mediterranean.
e-mail: thomasjmacmaster@gmail.com

Mariarosaria Salerno is Assistant Professor at the University of Calabria in Italy. She teaches Medieval History, and History of the Medieval Mediterranean. Her main research interests are on Military Orders, and Medieval Mediterranean, with a particular focus on issues related to relationships between Southern Italy and Maghreb. Among her recent publications are “Les templiers dans le sud de l’Italie (Abruzzes, Campanie, Basilicate, Calabre) : domaines et activités.” In *L’économie templière en Occident : patrimoines, commerce, finances, Actes du colloque international* (Aube de Champagne, 2013), pp. 115-137; “The Hospitallers in Southern Italy: Families and Powers.” In P. Edbury (Ed.), *The Military Orders-vol. V: Politics and Power. The Fifth International Conference to be held by the Cardiff Centre for the Crusades. Cardiff, 3-6 September 2009* (Ashgate, 2012), p. 263-272; and the edited volume *Confluenze nel Mediterraneo, tra storia e letteratura* (Liguori, 2012).
e-mail: mariarosaria.salerno@unical.it

Slobodan Dan Paich is Director and Principal Researcher of Artship Foundation in San Francisco, USA and Visiting Professor, Anthropology-Cultural Studies Section, Victor Babeş University, Timisoara, Romania. Slobodan Dan Paich has delivered numerous papers at international conferences as a keynote speaker and presenter. Those presentations are based his courses, lectures, and research since 1969, which address tangible and intangible heritage, comparative cultural studies, and the migration of techniques and ideas. The courses he initiated in 1969 at the college and university level broadened the scope of art history into the History of Art and Ideas. These courses included geographies larger than the European cultural sphere and an interdisciplinary, across-time curriculum was developed that included ancient and indigenous people as differently cultured, ingenious, and refined, rather than primitive.
e-mail: artship@aol.com

Stephan Sander-Faes is a senior research assistant at the University of Zurich's Department of History. He is also a visiting lecturer at the University of Fribourg. His main research interests are Renaissance and early modern Italy, with an emphasis on the economic and social history of the Venetian Republic, and Central Europe, with a particular focus on state and society in the early modern Habsburg monarchy. He is the author of *Urban Elites of Zadar: Dalmatia and the Venetian Commonwealth, 1540-69* (Viella, 2013), in which he critically questions the long-held belief about Dalmatia's long decline after the re-establishment of Venetian rule in the 15th century. Since 2011 he works on an analysis of the emergence of the Habsburg Monarchy as a great power during the late 17th and early 18th centuries.

e-mail: stephan.sander@hist.uzh.ch

Alessandro Buono is Marie Skłodowska-Curie Fellow at CRH-LaDéHiS, EHESS, Paris (France). He is also assistant lecturer (on contract) of "Military institutions of early modern period" at the University of Milan (Italy). His main research interest is the history of identification procedures, property and inheritance rights in Italy and in the Spanish Empire. His current research project aims at analyzing the ways in which the institutions of the early modern Spanish Empire identified the legitimate heirs of mobile individuals coming from the Iberian Peninsula who died suddenly, often without making a will, while they were in the monarchy's extra-European territories, thousands of kilometres away from their home towns. Among his recent publications are: "La manutenzione dell'identità. L'identificazione degli eredi legittimi nello Stato di Milano e nella Repubblica di Venezia (secoli XVII e XVIII)", *Quaderni Storici*, 148/1, 2015, pp. 231-266 and "Identificazione e registrazione dell'identità. Una proposta metodologica", *Mediterranea. Ricerche storiche*, 30, aprile 2014, pp. 107-120; and the monography *Esercito, istituzioni, territorio. Alloggiamenti militari e «case herme» nello Stato di Milano (secoli XVI e XVII)* (Firenze University Press, 2009).

e-mail: ale.buono@gmail.com

Federico Rigamonti is currently a novice at the Comunità monastica di Bose in Magnano, Italy, where he works as a librarian. His main research interests are, or rather were, economic and maritime history in the Early Modern Mediterranean, with a particular focus on issues related to the so called "Nordic invasion" and the somewhat clumsy relation between commerce, smuggling and privateering, and the ways they affected Italian merchants and seamen from the late Sixteenth to the mid-Seventeenth Centuries.

e-mail: federicorigamonti@libero.it

Acknowledgments

The editors would like to thank Harun Celik, Muhammed Asad Rafi and Zeynep Olgun for their invaluable help in editing and proof-reading the volume. Without them this book would not have been published.

Introduction
A Mediterranean of Traveling Faces and Ideas

ÖZLEM ÇAYKENT and LUCA ZAVAGNO

This selection of essays is the third edition of the Mediterranean Worlds (MedWorlds) Conference, which was held at the University of Salerno in 2011. Nevertheless, it is not simply the proceedings of a conference. In our opinion these carefully selected essays are a step along a long term and interdisciplinary effort to examine the diverse social, political, economic and religious aspects engrossing the matrix of communications across the Mediterranean basin from the early Medieval to the Modern era. The aim of this small conference was to bring together scholars from diverse backgrounds on a common theme to create a real “supradisciplinary” discussion zone. In this light these scholarly meetings had its origin largely in recent increase in a Mediterranean history whether it is commerce, politics or social aspects. In specific this interest is aims to look beyond the national and individual cultural territorial boundaries trying to establish the networks of communications in their various aspects.

The fruits of these meetings came together in 2009 with the publication of the proceedings of the first MedWorlds conference centered upon the interpretative issues of Mediterranean cultural encounters and continued few years later with the publication of the edited volume exploring the influence on and the role of the Mediterranean islands early modern and modern era (Khoo, Marotta & Zavagno, 2009; Çaykent & Zavagno, 2014).

Each of the abovementioned meetings took place at different locations that realised as the result of a collaborative effort among a growing number of different European and American institutions, which joined the ranks of the MedWorlds family. The result is remarkable. This volume brings together a constellation of a multi-focused collection of articles that explore the politics and economics of trade across the Mediterranean in the passage from the late Medieval period to the modern era; narratives centered upon the tangible and intangible aspects of commercial relationship across political, religious and cultural frontiers of the Mediterranean; a narrative piercing through the Commercial revolution of the

eleventh century when – as Cipolla states – mercatores dictated the tempo of a social and cultural revolution (Cipolla 1967: 52-7).

Since the volume includes papers on different aspects of the commercial dynamics – from historical to archaeological, from political to sociological – it aims at illustrating the important interactive role trade played within different Mediterranean societies stressing the continuity emanated from people (traders and other actors) and used spaces (trade routes) from the seventh to the seventeenth century.

Certainly, the array of essays in this volume is much indebted to two compelling volumes at the very heart of the historiographical debate on the Mediterranean: *The origins of European Commerce* by Michael McCormick and *The Corrupting Sea* by Peregrine Horden and Nicholas Purcell (McCormick, 2001; Horden & Purcell, 2000). Indeed, these seminal works have contributed to reassess the historiographical debate on the nature of Mediterranean communications, cultural interaction and political and economical relationship across different historical periods. In particular, as the latter stressed the importance of connectivity in the Mediterranean (with an ecological penchant), the former focused on the role of commerce and communications at the origins of the Mediterranean world as a vehicle for the creation of a European economy.

Although McCormick deals with the period 300-900 A.D., the methodological importance of his analytical approach moves beyond the late antique and early medieval period. A great deal of systematic and exhaustive collection of literary and documentary sources together with indirect evidence of communication and, material evidences (from coins to seals, from shipwrecks to ceramics) give us further clues in this methodology.

McCormick highlights the fact that rather than expecting that the sources provide us with what we want, we should take what they can give to us, for they give us communications (McCormick, 2001, p. 16.) In order to trace these communications McCormick insisted upon two sets of movements: the movement of individuals and of objects.

If independent sets of evidence continuously uncover the same patterns, chances are strong that those patterns stem from reality, and are not artifacts of the circumstances, which produced and preserved that set of evidence (McCormick, 2001, p. 18).

Upon presenting the reader with a wide array of objects that travelled (from relics to coins) and people on the move (from ambassadors to pilgrims), McCormick provided a richer matrix for patterns of Mediterranean communications not always commercial in nature.

With this caveats in mind this volume stresses the continuities in the dynamic connectivity of the Mediterranean. In fact there is an endless loop of continuously building, shifting and reestablishing of networks and goods traveling across the Mediterranean which reminds us of Penelope and her loom where endless threads and knots were made during the day and unraveled during the night. In a similar vein (loosely in tune with a Braudelian *longue durée*), the volume offers an interdisciplinary and encompassing digest over the manifold actors of this incessant

weaving and undoing of communications across different periods of Mediterranean history.

However, it is useful to emphasize that apart from the two above mentioned seminal works, this volume tries to follow the course of scholarly history set by those economic historians like Henry Pirenne, Carlo Cipolla, Roberto Sabatino Lopez, Emanuel Ashtor and more recently Richard Hodges, Angeliki Laiou, Cecile Morrisson, Karl Persson, David Jacoby and Chris Wickham (to quote just a few); rather than proposing a generalizing, macro-historical narrative of the trading institutions or merchant activities inhabiting the coasts of the *Mare di Mezzo*. The volume indeed explores a number of key studies (micro-histories) spanning across almost ten centuries of Mediterranean history.

The first essay by Thomas McMaster analyses the often invisible and faceless (in the written sources) groups of forced laborers, namely slaves. Dispelling the idea that the cultural unity of the Mediterranean was broken by the ruinous Muslim incursions, this paper stresses a re-orientation of shipping routes and trade patterns, which predated the appearance of Islam in the Mediterranean coasts. In tune with this idea of functional rearrangement of commercial relationships between western and eastern half of the Mediterranean, it also establishes the relationship of the Mediterranean to continental Europe.

The second contribution by Slobodan Paich partially moves away from the Mediterranean trade depicted by McMaster to usher the reader into the world of the abovementioned “faces who travelled” the exchange routes crisscrossing the Great Sea. Paich’s essay represents an audacious attempt to picture a diachronic and comparative backcloth of the maritime dynamics that aided or hindered flows of trade, populations and ideas. By looking briefly at itineraries of several carriers of intangible cargos of knowledge, inspiration and expertise the author reflects upon the history of the transmission of ideas and skills throughout the Mediterranean. In particular Paich’s attention focuses on late Byzantium and the life, travel and influence of Georgius Gemistus Pletho (1355-1454). His philosophy and life work summarizes intellectual currents of the Eastern Mediterranean and Asia Minor in the Late Middle Ages and even inspired Cosimo de’ Medici to found a new Platonic Academy.

In this light, Paich’s contribution is an ideal link to the second part of the book, which moves to communication and cultural traffic emanating from personal exchanges. Mariarosaria Salerno and Stephan Sander-Faes’s essays, offer excellent examples of inter-Mediterranean communications and relations generated through the role of elites. On the one hand we are presented with a complex coexistence of political and cultural implications of the long standing interest in and influence of the Maghrebi during the thirteenth and fourteenth century on the rulers of the Neapolitan Kingdom. On the other hand the second essay moving to the northern part of the peninsula dwells on the importance of “procuratorial” appointments for the reconstruction of ‘communication’ in Venice during the late Middle Ages and the early Modern Period. The suitable characteristics and advantages of the

procurae, indeed, make them an ideal tool to investigate the extent of Venetian commercial and political network of communications.

The next article by Alessandro Buono reminds us that the above mentioned network was also the results of the incessant travels of crucial group of border-crossers, the pedotti: a real maritime minority of professional ferries between Istria and the Serenissima who in the sixteenth century not only transported ships and goods but also contributed to forge a cultural link between the two sides of the Adriatic.

Finally, and in tune with the coda of the volume, Federico Rigamonti encourages the reader to look beyond the Mediterranean in a diachronic and comparative perspective. He is reflecting on the different modes, natures and trajectories of traveling and communications while at the same time analyzing the gravitational attraction exerted by the Mediterranean over Dutch traders -- with particular emphasis on their presence in Sicilian ports.

In conclusion, by looking at the plurality of lives and influences of different Mediterranean commodities and intellectuals, the abovementioned collection of articles reflect on and revisit the history of the transmission of ideas and skills from the Byzantine to the Ottoman era. Basically, journeys, and especially sea journeys with their onboard cargos both goods and people in an inescapable small space for several weeks/months, were the only tangible element in the convergence and divergence of worldviews. In these ship-spaces the arteries of trade routes became elusive carriers of songs, philosophies and technical know-how. In fact, whether the Mediterranean facilitates cultural and ethnic interplay, or whether we view it as a barrier that separates civilizations and traditions, a close study of Mediterranean on the sea exchanges can be very revealing. The history of transportation and commercial activities tell stories of men and cultures; the nature of individuals and societies; problems inherent in shipping and routes, as well as faiths of currencies and commodities. Looking at commercial activity and travelling is the method of mapping, reading and comprehending the Mediterranean world, and the dialogue of societies beyond its immediate shores. It reveals a dialogue shaped into an “intangible cargo” and transported across shipping routes often escaping the deeper glimpse of historians.

References

- Ashtor, E. (1976). *A Social and Economic History of the Near East in the Middle Ages*. Los Angeles: UC press.
- Çaykent Ö. & Zavagno L. (Eds.) (2014). *The Islands of the Eastern Mediterranean: a History of Cross-cultural Encounters*. London-New York: I.B. Tauris.
- Cipolla, C.M. (1967). *Money, prices and Civilizations in the Mediterranean World*. Princeton: Gordian.
- Hodges, R. & Whitehouse D. (Eds.) (1983). *Mohammed, Charlemagne and the Origins of Europe. Archeology and the Pirenne Thesis*. Ithaca-NY: Cornell University Press
- Horden, P. & Purcell, N. (2000). *The Corrupting Sea. A Study of Mediterranean History*. Oxford: Wiley-Blackwell.

Introduction. A Mediterranean of Traveling Faces and Ideas

- Jacoby, D. (2005). *Commercial Exchange across the Mediterranean: Byzantium, the Crusader Levant, Egypt and Italy*. Aldershot: Variorum.
- Khoo, T., Marotta, V. & Zavagno, L. (Eds.) (2010). Mediterranean Worlds: Cultures Issue of Interpretation. Proceedings of the I MedWorlds Conference, Famagusta 3-6 June 2009. *Journal of Intercultural Studies* 31 (3).
- Laiou, A. & Morrisson, C. (2007). *The Byzantine Economy*. Cambridge: CUP.
- Lopez, R.S. (1961). *Medieval Trade in the Mediterranean World*. NY: Columbia Univ. Press.
- McCormick, M. (2001). *Origins of European Economy. Communications and Commerce AD. 300-900*. Cambridge: CUP.
- Persson, K.G. (2010). *An Economic History of Europe: Knowledge, Institutions and Growth 600 to the Present*. Cambridge: CUP.
- Pirenne, H. (2001). *Mohammed and Charlemagne*. Dover: Dover Ed.
- Wickham, C. (2005). *Framing the Early Middle Ages. Europe and the Mediterranean. 400-800*. Oxford: OUP.

Part I

Medieval Mediterranean

Slavery and the Seventh Century Caesura

THOMAS MACMASTER

1. The Great Divorce?

At the beginning of the seventh century, the economies of the former Roman Empire remained focussed on maritime trade in the Mediterranean even if perhaps not what they had once been. The same key nodes (cities such as Marseilles, Carthage, Antioch, and Alexandria) had dominated it for centuries. A hundred years later, those patterns had all but broken down and several of those ports were all but abandoned. New patterns had begun to emerge which would remain in place in centuries to come. Where formerly the primary division in the Mediterranean had been between Latin West and Greek East, now a process of divergence had begun between an increasingly Arabic-using and Islamising south and the Christian north (where divergences between the remaining Greek and Latin areas also grew deeper). Trade between the main cultural provinces had receded and they had begun to go their separate ways.

In the last century, Henri Pirenne identified this period as the key break between the ancient and medieval economies. Rather than seeing the fifth century barbarian invasions and the Imperial collapse in the West as being a major dividing point, he argued for the essential continuity of the Mediterranean economy until the seventh century. In the decades since, of course, the study of Late Antiquity has advanced and increasingly proven Pirenne's view. However, Pirenne was almost certainly wrong when he ascribed the final breakdown of the ancient Mediterranean economy to "the rapid and unexpected advance of Islam" (Pirenne, 1954, p. 284).

The argument is premised on the notion that trade in the period would have simply ended when hostile states emerged on either side of the Mediterranean, a notion that flies in the face of much of human history. Trade and other economic activities have rarely ceased solely due to political hostilities; if anything, a state of war might make smuggling even more lucrative. Even if political decisions had led either the Christian or the Muslim states to deploy a trade blockade or economic

sanctions against the other, there is absolutely no evidence of it whatsoever nor is there even evidence of a *de facto* trade embargo.

Similarly, trade did not collapse from a lack of desire for eastern goods. The people of northern and western shores of the Mediterranean did not suddenly decide that they no longer wanted the products of the south and east; if anything, one would gather that, during the course of the seventh century, the economies of the countries around the North Sea were growing (Hodges, 1989)¹, and had far more desire (and ability) to obtain imports at the end of the century than at the beginning. So, it could not have been from a lack of demand that the trade ceased.

What will be argued below is that neither embargo nor warfare caused a breakdown in Mediterranean trade in the seventh century. Demand for eastern products (intellectual as well as physical) remained high in the Latin West throughout the period; if anything, demand was growing. Yet, the supply of east Mediterranean products and eastern treasure (as well as ideas) coming into the West fell rapidly in a series of dramatic drops in trade when the major export of Europe – Europeans – ceased to be a lucrative trade.

To understand what happened, the Mediterranean trading system as it appeared around the year 600 will first be examined before looking at that same region in the early eighth century. Once the magnitude of the rupture is understood, we will attempt to date it more closely using two principle lines of evidence, texts and coins; from these, as well as from material covered earlier, it will become clear that while trade did not decline all at once, it did so in what can be described as a series of punctuated collapses. These can be dated and compared to the public events of the time. Those parallels will make it clear what actually happened and the role of the shift in the slave trade in the period.

2. *Mediterranean economic systems at the end of the sixth century*

At the end of the sixth century, the economy of the ancient Mediterranean continued to function, even if it was not as robust as it had once been. A glance at the histories of Gregory of Tours or the voluminous correspondence of Pope Gregory the Great can demonstrate that trade and communications around the Mediterranean appear to have been active and vital as they had been in earlier times.

While both the collapse of Roman rule in the West during the fifth century and its partial restoration in the sixth century had drastically altered political geography, effects on economic systems were somewhat more limited. When the Vandals had conquered North Africa, they had at a stroke deprived the Western Empire of one of its main sources of revenue and ended the subsidised provisioning of the

¹ Hodges (Hodges, 1989) suggests that Quentovic emerged as an emporium from the 560's, Dorestad was founded c 670, Hamwic, c. 690, and Lundenwic re-emerges in the same period (p. 94).

city of Rome². At the same time, Vandal Africa experienced marked prosperity; freed of central government control, African exports to areas beyond Rome grew and more than made up for the loss of the guaranteed markets (Hitchner, 1992, p. 123). Similarly, the restoration of Imperial rule in North Africa, Italy, and parts of Spain does not appear to have substantively altered economic patterns.

Instead, the trade systems of the Roman world continued and, if anything, the export of humans as merchandise had steadily increased from the new ‘barbarian’ kingdoms³. In return for the human cargoes, an array of products was shipped to

² See Wickham, 2005, for an extended argument on the role of the collapse of state economic activities that followed from the loss of North Africa.

³ The invasions probably brought an increase in the extent of slavery. While many individual slaves are reported to have fled to the barbarians (Zosimus, *Nova Historia*, 5.13, describes slaves joining the revolt of Tribigild in 399 and, a decade later, 40,000 slaves fleeing Rome to join the forces of Alaric (5. 42). Other fifth century sources, including Salvian (*De gubernatione de Libri VIII*, 5.5 – 11) and Orosius (*Historiarum Aduersum Paganos Libri VII*, 7.40 – 41), appear to assert that the defection of slaves to the barbarians was common (though it should be remembered that both were writing as critics of Roman society, rather than as historians), the newcomers were hardly emancipationists. (Even if one doubts E. A. Thompson’s view (Thompson, 1956) that the primary motivation behind the Imperial settlement of Visigoths, Alans, and Burgundians in Gaul was motivated by a desire to defeat the Bacaudae, who, at least in Thompson’s view (Thompson, 1977; where they are credited with a national liberation movement that created a grand worker and peasants collective) are understood as social revolutionaries freeing peasants and liberating slaves (an idea wholly unsupported by the evidence), it is clear from sources such as the writings of Apollinaris Sidonius (*Epistolae*, 1.2, etc) and his circle that the great landowners of southern Gaul were quick to find a mutually acceptable accommodation with fellow slave-owners.) Instead, regardless of the precise mechanics by which the new military elites were after the conquest, it is probably safe to say that the units in which the benefits of the conquests were allocated among the invaders were largely territorial or fiscal. Certainly, all the barbarian peoples relied on slaves for labour and all of them had profited immensely from the sale of captive civilians as well as defeated enemies. Marseilles, for instance, grew markedly in the fifth and sixth centuries as an emporium handling the exports of Gaul and literary sources point to its major export as being humans brought from further north. Bede, *Historia Ecclesiastica gentis Anglorum*, 2.1 contains the famous story of Gregory the Great encountering English slaves in the Roman market, c. 590; a somewhat different account from Bede is found in the *Vita Sancti Gregorii I Papae*, 9, written somewhat earlier (late seventh/early eighth) at Whitby. There, the Angles are not described as slaves (nor as youths) and Gregory summons them to his presence rather than finding them in the market place. Gregory the Great himself had English slaves purchased at Marseilles as part of the mission to England a few years later (*Registrum Epistolae*, 6.7). English slaves are mentioned later in the century as part of the cargo of ships (presumably passing through Marseilles): «Sane ubicumque uenundandum intellexisset mancipium, magna cum misericordia et festinatione occurrens, mox dato praetio liberabat captiuum; interdum etiam usque ad uiginti et triginta seu et quinquaginta numero simul a captiuitate redimebat; nonnumquam uero agmen integrum et usque ad centum animas, cum nauem. egrederentur, utriusque sexus, ex diuersis gentibus uenientes, pariter liberabat, Romanorum scilicet, Gallorum atque Brittanorum necnon et Maurorum, sed praecipuae ex genere Saxonorum, qui abunde eo tempore ueluti greges a sedibus propriis euulsi in diuersa distrahebantur. (Dado of Rouen, *Uita Eligiius Episcopi Nouiomagensis*, 1.10. Truly, in whatever place he understood that slaves were being sold, with great mercy and haste he rushed, soon freed the captive at the given price: sometimes as many as even twenty or thirty or even fifty captives he redeemed at the same time: sometimes even a hundred souls at once, when in a ship, they came out together of both sexes and coming from different nations, he freed them together, Romans, namely, Gauls and

the northwest from the eastern Mediterranean. A great deal is known about what sort of things were being exported from North Africa and the eastern Mediterranean to Western Europe at the time. These goods were not simply the wine, oil, and fine pottery⁴ that appear on western sites nor were the ships that sailed small vessels⁵. While many of the other goods have left little in the archaeological record, the surviving scraps of literary evidence sometimes reveal objects that otherwise would have left little trace. Many trade goods appear by chance through comments such as those with which Gregory of Tours rebukes the Bishop of Nantes: «Oh, if only you had been bishop of Marseille! Then, its ships would never have had to carry oil but only paper so that you could have a better opportunity to defame the good' (Gregory of Tours, *Decem Libri Historiarum*, 5.5.)»⁶.

These comments show that Egyptian papyrus was still the principle material for writing letters. Elsewhere, he shows that wine from Gaza is regularly drunk on the Loire⁷. Just as churchmen in north-western Gaul relied on imports of writing materials and wine from across the sea, Frankish churches continued to be lit with lamps burning imported oil, rather than locally available candles (Fouracre, 1995, p. 70). Meanwhile, Gregory depicts ambassadors regularly sailing between Marseille and Constantinople⁸ and even tells of how Byzantine coin funded an attempt-

Britons as well as the Moors but especially from the nation of the Saxons, who were as numerous at that time as if they were a herd expelled from their own land and scattered everywhere».

⁴ See below for examples of all three. Much wine and oil was carried in ceramics through this period and pottery has been used to track their export. Unfortunately, this was also in flux at the time as wine and oil were increasingly shipped in wooden barrels and casks while the ceramic traditions were about to come to an end. Both Phocaeen Red Slipware and African Red Slipware traditions end in the late seventh century after a steady decline in production over the preceding decades. The last Phocaeen RS dates from sometime in the last quarter of the century while the last ARS from right around the year 700 (722-724) (Wickham, 2005). As these had been major export wares throughout the Mediterranean, their disappearance is significant for tracking commerce. Other more localised wares had also seen an end to large-scale production, notably in Lombard Italy at mid-century (732) and localised traditions there and elsewhere replaced the former imports. In inland areas, whether in Syria, Spain, or northern Gaul, local traditions had always dominated. Only in Egypt did truly massive potteries continue to exist throughout the seventh century and into the eighth (and beyond) without interruption (762).

⁵ An Alexandrian vessel that sailed from Egypt to Britain and back is mentioned by Leontius of Neapolis (*Vita Sancti Iohannis Eleemosynarii*, 10) as having a cargo of 20,000 bushels of wheat would have had a holding capacity of at least 594 tonnes. A fleet of thirteen ships each with a capacity of 10,000 bushels are also mentioned by Leontius as operating in the Adriatic (28) while the ships described as taking part in the Battle of the Masts (655) included vessels capable of carrying large catapults and towers and, if not exaggerated, companies of over 1,000 warriors (Sebeos, *Patmut 'iwn Sebeosi*, 50: 1710-1711). Ships of considerable size have even been found from the period; a vessel found off the coast of Sicily dating from the 530's carried over three hundred tonnes of worked marble (ship no. 671) while a vessel sunk in 626 carried over eight hundred large amphorae (no. 1239) (Parker, 1992).

⁶ Gregory of Tours, *Decem Libri Historiarum*, 5.5: «O si te habuisset Massilia sacerdotem! Numquam naues oleum aut reliquas species detulissent, nisi cartam tantum, quo maiorem oportunitatem scribendi ad bonos infamandos haberes».

⁷ Gregory of Tours, 7.29. See Philip, 1985.

⁸ Gregory of Tours, 6.2.

ed usurpation based in Constantinople⁹. Certainly, whether they were ambassadors or other travellers, Gregory had sources that provided him with miraculous stories from the Eastern Empire (Gregory of Tours, *Liber in Gloria Martyrum*, pp. 5, 30, 102). A Syrian friend named Iohannes provided a text and helped him translate the tale of the Seven Sleepers of Ephesus into Latin, a Syriac Christian folktale previously unknown in the West (Gregory of Tours, *Passio Sanctorum Septem Dormientium Apud Ephesum*, p. 12)¹⁰.

Similarly, the letters of Pope Gregory the Great (590-604) reveal a world where reliable fast sea communications ran from Rome not only to Marseille (Gregory the Great, *Registrum Epistolarum*, 1.45, 6.52, 7.12, 9.209, 11.10, 11.41)¹¹ and towards Spain (*Registrum Epistolarum*, 1.43) but also to Carthage (*Registrum Epistolarum*, 1.61, 1.74, 1.75, 1.77, 6.63), Constantinople (*Registrum Epistolarum*, 1.4, 1.5, 1.25, 6.65, 7.33), and Antioch (*Registrum Epistolarum*, 1.7, 1.25, 1.26, 8.2). The Pope could carry on a long exchange with the Patriarch of Alexandria over the export of Italian timber to Egyptian shipyards (*Registrum Epistolarum*, 6.58, 7.37, 8.29, 8.38, 9.175, 13.45) while also writing to kings (*Registrum Epistolarum*, 9.109) and queens (*Registrum Epistolarum*, 9.216) (as well as churchmen)¹² (*Registrum Epistolarum*, 11.10) in Gaul regarding what he saw as distasteful trade policies (*Registrum Epistolarum*, 6.29, 9.36, 9.105)¹³.

In the writings of the period, east Mediterranean merchants appear frequently. Many of them are based firmly in the cities of the West while others seem to be itinerant traders. As Syrians, they are far from rare in Gaul (Gregory of Tours, *De Gloria Martyrum*, pp. 94-95; Gregory of Tours, *Decem Libri Historiarum*, 7.29, 8.1, 10.26)¹⁴ and are also known from Spain (Gonzalez, 1979, p. 688)¹⁵. Jews, too,

⁹ The pretender Gundovald landed in Marseille in 582 and claimed to be Chlothar's son, coming directly from Constantinople with Byzantine treasure. Bishop Theodore of Marseille supported him but was accused by Count Guntram Boso of supporting a plot to restore imperial rule in Gaul (Gregory of Tours, 6.24). The notion that the Empire continued to be interested in restoring its rule in Gaul appears to have been an established view there. Note also Ebroin's reaction to Hadrian and Theodore when they were en route to Canterbury in 668-669 (Bede, *Historia ecclesiastica*, 4.1).

¹⁰ Gregory of Tours, *Passio sanctorum septem dormientium apud Ephesum translata in Latinum per Gregorium episcopum Turoicum*, 12. Curiously, the same story is repeated in the *Quran* (18: 9-26).

¹¹ Amongst the recipients of Gregory's letters were Bishops Virgil and Theodore (*Registrum Epistolarum*, 1.45), Bishop Serenus (6.52, 9.209, 11.10, 11.41), and Abbess Respecta (7.12). He mentions receiving a petition from Dynamius, the governor of the city (7.12).

¹² In a letter that would later be useful in explaining the Papacy's teachings on icons, Serenus, the Bishop of Marseille, was criticised for his opposition to the use of images and preaching against them. Though the iconoclast controversy still lay more than a century into the future, it seems that Serenus was already anticipating many of the positions that would later be articulated; Gregory criticised his proto-iconoclastic position in what would similarly become the Roman Church's response, telling him that images were necessary for the teaching of the ignorant (11.10).

¹³ Specifically, the Pope was disturbed by reports that the Frankish monarchy tolerated Jewish ownership of Christian slaves and the involvement of some Jewish merchants in slave-trading in their kingdom.

¹⁴ Gregory of Tours, *Decem Libri Historiarum*, 7.29, 8.1, 10.26, *De Gloria martyrum*, 94-95, etc. See also Jonas of Bobbio, *Vita Columbani*, 1.41. It has been suggested that many of these Syrians

appear frequently as merchants involved in the maritime trade of the Mediterranean¹⁶ and, in this period, Jewish merchants appear as originating in the east¹⁷. Of course, none of the Christian sources appear to have much kindness for them; whether the Jews are depicted as ship-owners (Gregory of Tours, *Liber in Gloria Confessorum*)¹⁸ or slave-traders (*Registrum Epistolarum*, 6.29, 9.36, 9.105)¹⁹, they come in for condemnation. Similarly, Egyptian ships are mentioned as sailing to the western Mediterranean by both western and Egyptian sources²⁰. Yet, while easterners of various origins are found journeying to all parts of the Mediterranean and even beyond, there was no opposite movement visible of western ships or traders; those westerners found in the eastern Mediterranean appear almost exclusively

were Monophysites and that Gregory's Christology (*Decem Libri Historiarum*, 5.43-44) might be read as showing a Monophysite influence.

¹⁵ Gonzalez, 1979. Gregory, a Syrian merchant and representative of the Acephali (an extreme Monophysite sect), presented himself before the 619 Council of Seville; this might suggest that such visitors were a normal feature of the time.

¹⁶ See Gregory of Tours *De Gloria Martyrum*, Gregory the Great notes that a significant trade in slaves shipped from Marseilles and bound for other parts was in Jewish hands. Writing to Fortunatus, the Bishop of Naples, he set down strict guidelines stating that if the slaves owned by Jews were pagans, that was permissible but that the Church would intervene and take the slave if the slave desired baptism (6.29). In a later letter, also to Fortunatus, he describes this Jewish traffic in more detail (see Appendix A). Other letters show Jewish slave traders in Narbo (7.21) as well as Marseille. Jews appear as merchants – though never explicitly as slave-traders – in the same regions and at the same time in the works of Gregory of Tours. He tells how, when the Bishop of Clermont decided to forcibly baptise the entire Jewish community of his city, five hundred of them had fled to Marseille to escape (*Decem Libri Historiarum*, 5.11). There, they likely would have found a large and prosperous Jewish community that appears to have been heavily involved in long distance trade (though as yet no trace of the Jewish community has been found in the digs there). Jews appear in his work as merchants, including one Priscus who was described as King Chilperic's familiaris and agent in buying costly goods. (6.5). Though Priscus is described as a friend of the King's, this does not spare him from the king's aggressive Christian proselytizing. Similarly, Priscus's kinsmen, when he is eventually slain, avenge him in typically Merovingian style (6.17).

¹⁷ See *Doctrina Iacobi nuper Baptizati*, 5.20, describes the principle character, Iacob, as having originated in Palestine and being involved in trading voyages between Constantinople, Carthage, and Gaul. Ioustos, in the famous passage regarding what is probably Muhammad (5.16), reads from a letter sent to him in Carthage by a relative in Caesarea. These stories may reflect the reality of the time: in 614, the Jewish population of Palestine was in the range of 15-25% of the total population of Palestine (which was probably at or near its pre-twentieth century population peak). Similarly, large Jewish communities are attested elsewhere in Syria (at Antioch, Edessa, and Dera'a, among others) as well as in Egypt and other eastern lands.

¹⁸ In the *Liber in gloria confessorum*, Gregory of Tours recounts how, after the confessor Hospitius died in 581, a man gathered some relics from his tomb and wanted to sail with them from Nice to Lerins but the only boat available was a ship bound for Marseille. As Jews owned it, he had to be cautious regarding sharing his purpose but, when he revealed what he carried to them, they miraculously landed him at Lerins (95).

¹⁹ Gregory the Great, *Registrum Epistolarum*, 6.29; 9.36; 9.105. See above.

²⁰ E.g., See Gregory the Great, *Registrum Epistolarum*, both Leontius (9-10) and Gregory the Great (6.58; 7.37; 8.29; 8.38; 9.175; 13.45) refer to the apparently very active shipping interests of the Alexandrian Patriarchate.

to have used eastern shipping (Gregory of Tours, *Decem Libri Historiae*, 10.2)²¹. Marseille and other western ports might have grown rich from trade with the East but they were largely passive participants, merely waiting for the voyagers from the east to come to them with their cargo.

This was a continuation of earlier patterns. Since at least the fourth century, most shipping and long-distance trading in the Roman world was by Levantines and Egyptians (McCormick, 2001, pp. 103-105)²². Even in the Aegean and along the coasts of Asia Minor, Syrian and Coptic mercantile-shipping had long since overwhelmed the local carrying trade while the same appears true in the ports of North Africa. While eastern ships regularly sailed to all the ports of the Mediterranean and beyond – trade at a modest level was even carried on directly between the West coast of Britain and Egypt (Campbell, 2007, pp. 129-131)²³ – very few ships went in the opposite direction. Trade, such as it was, was almost entirely transacted along lines defined by the easterners.

While the east Mediterranean served as the hub of trade networks linking sub-Saharan Africa (via the Nile), the Red Sea, the Indian Ocean, Persia, Central Asia, and onwards through China to the farthest east²⁴, western demand for silk, spices, ivory, gold, and other items brought by east Mediterranean merchants was not enough to drive trade. Similarly, while Egypt and the Levant were the most developed economies of the time, consistent surpluses of manufactured goods or agricultural products did not drive a search for new markets. Instead, these eastern merchants came to ports like Marseille from Carthage, Alexandria and the Levant to obtain something they believed could be sold at home at a profit. Whatever it was, one would expect it to have been something readily available in western ports at a substantially lower cost than in the East.

Besides the tin imported directly from Britain to Egypt on at least one occasion, there were very few products of Britain or the Gauls (or even of Spain and Italy) that east Mediterranean peoples would have been unable to find more readily available closer to home. Western wines were inferior; Western pottery was unwanted and Western grain and other foodstuffs were unwanted; even Western textiles were markedly inferior to those of the East. Some timber was exported to Egypt – the Alexandrian patriarchate sought timber in Italy for ship-building (*Registrum Epis-*

²¹ Gregory of Tours, *Decem Libri Historiae*, 10.2, provides a description of a Frankish embassy to Constantinople in 590; they ran into difficulties in Carthage while waiting for a ship to carry them onwards. While more detailed than most, it seems typical for the period. There is no evidence for use of the land route through the Balkans after the migration of the Lombards.

²² From the middle of the fourth century onward, the majority of shipping in the Mediterranean had been carried in Levantine and Egyptian boats. That trend had accelerated in the fifth century (McCormick, 2001).

²³ Leontius describes large Egyptian ships trading directly with the west coast of Britain (10); such voyages are archaeologically attested (Campbell, 2007).

²⁴ Note that the Nestorian stele from Chang'an dates the arrival of Syriac Christianity in China to 635. Christianity arrived along the increasingly active trade route from the Mediterranean to China leading through Persia and Central Asia.

tolarum, 6.58, 7.37, 8.29, 8.38, 9.175, 13.45)²⁵ – and wood might have been a marginal export (though there were sources far closer, including the Lebanese cedar forests) (Liphshitz, Biger, Bonani, & Wolfli, 1997, pp. 1045-1050). The amount of timber, tin, and similar raw materials sent east and south though appears unlikely to have been enough to balance trade. While an occasional exploratory voyage might be made to find new markets for trade and that such might return home with an empty ship, such chance events simply cannot account for the amount of trade that demonstrably did occur²⁶.

Instead, by far the largest export of the West and, probably, the force driving this trade was that in humans. Slaves appear constantly in the texts, whether as captives in some of the many wars, as labourers, or as objects of trade, as one would expect considering the vast number of slaves needed to maintain the economies of the time. Walter Scheidel has argued that the Roman economy needed between a quarter and a half million new slaves per annum in the first centuries of the era (Bradley, 2011, p. 309).

Whether populations as a whole had shrunk or not since that time, the demand had remained enormous. The collapse of Roman rule in the West meant a massive increase in wars and, with them, enslavements; enormous numbers had been imprisoned in the European provinces, whether as civilians captured by raiding bands and invading armies or as defeated warriors. Some of these captives were quickly freed²⁷ but many more must have been sold as slaves. Whether a slave had started life Roman or barbarian and regardless of what had led to enslavement, the slave would be taken to market and sold. While some were sold locally, many would be taken to Marseille or one of the other ports and from there sold on to points all around the Mediterranean.

While the period saw impoverishment in some regions overrun by barbarians, other Mediterranean areas were prospering and presumably needed new labour. The areas where prosperity was most marked in the period – Syria, Egypt, and North Africa – were precisely those that were exporting materials to the West (Hitchner, 1992, p. 126)²⁸. The ships bringing goods westwards would not have returned empty; the abundance of low-cost captives were a natural export.

²⁵ Gregory the Great, *Registrum Epistolarum*, 6.58; 7.37; 8.29; 8.38; 9.175; 13.45.

²⁶ Such might account for some evidence; only a handful of voyages would account for most of the known eastern remains found in Britain between 400 and 700.

²⁷ I.e., the frequent hagiographic topos of the redemption of captives, found for a great many saints in the areas where wars were waged. See Graus, 1961 for the most thorough exploration of this topos in the period. In general, it usually refers to redemption of captives (free people carried off by invading or raiding forces) though sometimes those freed have already been trafficked beyond their homeland.

²⁸ Eastern Mediterranean amphorae began arriving in Gaul in large numbers in the late fourth century and, at Marseille, they then comprised roughly 37-40 % of the trade while African amphorae made up about 20-22%. Similar ratios were also found at Arles (40% eastern to 30% African) and Beaucaire (48% eastern, 42% African). However, it is worth bearing in mind that the African amphorae are generally larger than eastern ones at Marseille. By the late sixth century, though, African amphorae made up over 50% of imports and eastern ones only 25%. That trend continued into the seventh century, when more than 90% of the amphorae were African in origin.

These traders from the east Mediterranean ports followed a route visible in both texts and archaeology that would have seen the majority of long-distance trade from Gaul, England and Germany passing through Marseille before being shipped eastward via Carthage (McCormick, 2001, p. 107). From Carthage, eastern goods were carried onwards to Marseille in cargoes of primarily African products before being exchanged for Gallic exports and a return journey made. From Carthage, slaves would be shipped onwards to Egypt, the Levant, or Constantinople.

In the ships bound southward from Marseille there would have been cargoes of humans. Some – possibly even the overwhelming majority – made it no farther than Carthage. In the last years of the sixth century and the first years of the seventh, North Africa appears to have been as peaceful as it had been in centuries and its economy was expanding. Whether the slaves brought from the north were needed for their labour or were viewed as luxuries, Africa in these years was unquestionably a major importer of labour though some slaves would have been transported on further to the east, to the prosperous regions of Egypt and the Levant.

This economy is that which might be termed a “late antique” one, with the same heavy emphasis on Egypt and the Levant that that term frequently implies. By the beginning of the seventh century, many of the cities of the West had shrunk substantially since the High Empire (Rome being by far the most obvious example)²⁹ and the former Western Empire was materially more impoverished than it had been. But, at the beginning of the seventh century, the patterns of trade revealed in both texts and archaeology remained fundamentally those of the ancient economy.

3. Mediterranean trade in the first decades of the eighth century

Yet, if the patterns of trade at the beginning of the seventh century were recognisably those of earlier antiquity, by the time another century had passed, they had changed utterly. These changes were not seen as permanent at the time as demonstrated by a charter referring to customs duties at the port of Fos³⁰ issued on 30 April 716 by Chilperic II:

To the pious and venerable abbot of the monastery that is called Corbie, which is recorded in the district of Amiens, to which either our uncle, the late and beloved king Chlothar, or the lady and our grandmother, the queen Balthild, once, on account of the love of Christ in honour of Saint Peter and Saint Paul, chief of the apostles, and of the holy Martyr Stephen, caused to have been built, was added to our presence, suggested to the gentleness of our kingdom, because they said our uncle, the late king Chlothar, he also said our grandmother, lady Balthild the queen, so that the monks there might con-

²⁹ Marcellinus Comes, *Chronicon cum Additamento ad A. DXLVIII*, 9th Indiction, 6th Year (546): «Postquam deuastationem quadraginta aut amplius dies Roma ita fuit desolata, ut nemo ibi hominum nisi bestiae morarentur».

³⁰ Fos, the modern Fos-sur-Mer, is located (and receives its name) at the mouth of the Roman Fossae Marianae, the canal dug by Caius Marius to connect the Rhone directly with the sea. It is unclear when the canal ceased to be in operation. The port itself seems to have been a subsidiary of that of Marseille during the Merovingian era.

sistently hold vigil, they conceded from the tolls collected at Fos be given every year to the monastery; that is, 10,000 pounds of oil; 30 measures of fish sauce [garum]; 30 pounds of pepper; 150 pounds of cumin; 2 pounds of cloves; 1 pound of cinnamon; 2 pounds of spikenard; 30 pounds of costmary; 50 pounds of dates; 100 pounds of figs; 100 pounds of almonds; 30 pounds of pistachios; 100 pounds of olives; 50 pounds of hidrio [?]; 150 pounds of chick-peas; 20 pounds of rice; 10 pounds of golden pepper [white pepper?]; 10 seoda [?] hides; 10 Cordovan hides; 50 tomi of paper; we command that the tolls, after the Fos custom house has seen them collected, from each year's taxes all will have been sent to the monastery, as it has been drawn up, to give and to fulfil, and rather than that they be sent themselves to collect, which requires that they go there, without every year giving a new deed; this is 10 cart-horses or palfreys, 10 loaves of bread, twenty of the following, 1 measure of wine, 2 measures of beer, 10 pounds of bacon, 20 pounds of meat, 12 pounds of cheese, 20 pounds of peas, 1 goat, 5 chickens, 10 eggs, 2 pounds of oil, 1 pound of fish sauce, 1 ounce of pepper, 2 ounces of cinnamon, salt, vinegar, herbs, sufficient wood (*Diplomata Regum Francorum*, 86)³¹.

These items include not just products from around the Mediterranean (olives, dates, pistachios, fish-sauce, cumin, Cordovan leather, etc.), sometimes in enormous quantities, but things that came from even farther away: cinnamon and pepper from southern India, spikenard from the Himalayas, and even cloves brought from as far away as the Moluccas (a distance of seven thousand miles). Taken at its face value, the charter implies that, in the second decade of the eighth century, a truly massive amount of trade was still reaching Gaul from all parts of the Mediterranean and beyond.

A closer examination may make it seem somewhat less likely. Among the products listed were fifty *tomi* of Egyptian papyrus. Depending on the size of a *tomus*, this may have been as many as 25,000 large sheets every year (Bertelli, 1998, pp. 43-44; Loseby, 2000, p.187). Yet, even the charter itself demonstrates the changes that had occurred; it was written on the more expensive (but locally produced) parchment as papyrus was no longer available in Gaul in any amount (Wellhausen, 1963, p. 217)³². Gregory of Tours had considered papyrus as a major import of

³¹ *Diplomata Regum Francorum*, 86: «Igitur relegiosus et uenerabilis abba de monasterio cognominante Corbeia, qui ponitur in pago Ambianense, quem praecelsus auunculus noster Chlothacharius quondam rex, uel domna et aua nostra Baldechildis quondam regina, ob amorem Christi in honore sanctorum Petri et Pauli, principes apostolorum, et sancti Stephani martyris uisae fuerunt construxisse, ad nostram accessit praesentiam, climentiae regni nostri suggessit, eo quod praefatus auunculus noster, Chlothacharius quondam rex, seo etiam dicta aua nostra domna Baldechildis regina, unde lumenaria monachis ibidem consistentis habere deberent, de tulloneo de Fossas annis singulis ad ipso monasterio concesserunt: hoc est, oleo lib. 10 millia, garo modios 30, pipere lib. 30, cumino lib. 150, cariofile lib. 2, cinamo lib. 1, spicio lib. 2, costo lib. 30, dactilibus lib. 50, karigas lib. 100, amandulus lib. 100, pistacias lib. 30, oliuas lib. 100, hidrio lib. 50, cicer lib. 150, oridia lib. 20, auro pimento lib. 10, seoda pelles 10, cordeuisae pelles 10, carta tomi 50: ita ut telonaria, qui post teloneo Fossense agere uidebatur, anno illatione haec omnia ad missus ipsius monasterii, qui inde directi fuerint, dare et adimplire, immoque et euectione ad ipsus missus, qui hoc exigeri ambularent, perpetualiter absque renouata tracturia annis singulis dare praecipemus; hoc est uiredus siue paraueridus decem, panis nitedus decem, sequentes uegente, uino mod. 1, ceruisa mod. 2, lardo lib. 10, carne ponda uegente, cassio lib. 12, pisus lib. 20, capro 1 pullus 5, oua 10, oleo lib. 2, garo lib. 1, piper uncia 1, cimina uncias 2, sal, acetum, olera, lignum sufficienter».

³² The production of papyri remained a state monopoly in Egypt throughout the period. Even after the Islamic conquest (639-642), export of it to Constantinople (and elsewhere) had remained a major

Marseille, and, though parchment had been becoming more frequently used from the fourth century onwards, it continued to be used until the middle of the seventh century both for books and documents (Bischoff, 1986, p. 8). Sixth and seventh century texts composed in Gaul survive in papyrus (Bischoff, 1986, p. 8; Hen, 1995, p. 41)³³ while it continued to be used for charters for as long as it was possible. Papyrus appears to have been the preferred material for official documents even after parchment had begun to be widely used in books, yet, from 673, parchment began replacing it; the first parchment charter was issued on 10 March of that year and, after it, papyrus would only be used in Gaul three more times (in 690, 691, and 700) (Levillain, 1944, pp. 5-6). One can posit that these were among the last scraps of papyrus available in Gaul (Lewis, 1951, p. 93)³⁴.

The Corbie charter also appears at second glance to be referring to a reinstatement of privileges given to Corbie by the founders of the monastery, Queen Balthild and her son Chlothar, between 659 and 661. When it was made, such imports appear to have still been possible but papyrus and other items began to become harder to find in southern Gaul at around that time. Yet, while the trade of Marseille and similar Mediterranean ports withered and imports all but disappeared, long-distance trading had not vanished.

Instead, trade was expanding and flourishing elsewhere. In the North Sea regions, a new economic dynamism had begun to emerge centred on newly established trading communities like Hamwic and Dorestad as well as the revival of towns like London. A silver-based currency began to appear there; by the early eighth century (at the latest), it had replaced its gold predecessor. Merchants steadily expanded into outlying regions to the north and east. Within another century, closely linked trading communities would be found northwards into the Baltic Sea and beyond. Similarly, the same period saw the growth of both sea-borne trade in the Indian Ocean, Red Sea and Gulf as well as in overland trade across the Sahara and eastwards into Asia. Trade into these regions expanded even as Mediterranean trade died. In Syria, the inland cities – Aleppo, Homs, and Damascus – grew while the Levantine ports withered. The economy of the ancient world had died.

The eastern imports known from sixth and early seventh century Gaul and beyond had virtually disappeared from the West well before the Merovingian dynasty lost power. East Mediterranean and North African pottery had disappeared from Western Europe. Just as papyrus ceased to be used in Western chanceries and replaced with parchment, candles had replaced oil lamps in the churches of Gaul

source of Egyptian revenues but sometime around 692, Abd'l Malik banned export to the Byzantines at the outbreak of the hostilities that would lead to the Byzantine loss of Africa.

³³ Hen refers to manuscripts of Avitus from the sixth century while Bischoff notes that one of the last known papyrus manuscript from the West is a Luxeuil codex containing Augustine's writings. One must wonder whether part of the reason that so few Merovingian texts survive compared to Carolingian ones is due to the use of papyrus, a material that would not last nearly as long in the more humid climates of Europe.

³⁴ The last use of papyrus in the Lombard kingdom comes from 716.

(Fouracre, 1995, p. 70). Gold coinages ceased production and fell out of use³⁵. Along with such tangible items, knowledge of developments in the eastern Mediterranean and North Africa became far more confused. The trade links between the eastern Mediterranean and Western Europe all but disappeared and a sea that had been the centre of economic exchange as well as of political and cultural unity rapidly became a frontier zone separating diverging cultural blocs, a pattern that would endure.

4. Dating disruption: Information gaps

The collapse of trade had come quickly and it may be possible to date this more closely. One possible route might be through texts. While the corpus of west European literature from the seventh century is relatively small, one can see an interesting trajectory in it when it comes to reports of news from the East. At the beginning of the century, interested observers in Gaul³⁶ or Spain³⁷ (if not in the British Isles) were well aware of events in the eastern Mediterranean. They knew who was currently Emperor and a great deal of what happened in cities like Constantinople, Antioch, Jerusalem, and Alexandria. Ships came frequently; perhaps more important than their cargoes were the people that were carried on them. The textual evidence strongly suggests that, just as under the Empire, news and ideas could still spread rapidly from one end of the Roman world to the other.

That pattern broke down, though, sometime in the second quarter of the seventh century. While western reporters had been aware of the eruption of warfare between the Persians and Byzantines at the beginning of Heraclius's reign and reports can be found of key events through the late 620's³⁸, no one in the seventh century West seems to have been aware of the recovery and restoration of the True Cross at the end of that war (though that event was very well known later in the West)³⁹.

³⁵ See below.

³⁶ See the eastern materials in Gregory of Tours as well as the *Chronicle of Fredegar*.

³⁷ See Isidore of Seville's *Chronica Maiora*, 414-416; written in 626, it recounts the loss of provinces to both the Persians and the Slavs. An earlier 615 version of the same text merely identifies the Emperor's accession. Note also the lengths to which the Second Council of Seville in 619 went to combat Monophysitism.

³⁸ See, for instance, the *Chronicle of Fredegar*, 4.64, regarding the Battle of Nineveh in 627. The Frankish chronicler depicts him as defeating the Persian champion in single-combat while, in Theophanes, *Chronicle*, AM 6118, the same feat of arms is depicted and the Persian named as Razates. In Fredegar's account, Heraclius is referred to as a 'second David'; curiously, a series of silver plates found in Cyprus may show that this analogy came from the Court of Heraclius (Wander, 1975). All suggest that, as of 628 or so, the Fredegar chronicler is well-informed of Byzantine propaganda. Note that the author reports the return to Gaul of an embassy to Constantinople in 629 (*Chronicle of Fredegar*, 4.66) that had, in his words, made a permanent peace. This is the last attested journey between Constantinople and Gaul in the seventh century (save for Arculf).

³⁹ See, for instance, the use made of it by William of Tyre (*Historia rerum gestarum in partibus transmarinis*, 1.1-2) and other Crusade-era historians or its appearance in the Golden Legend (Jacobus de Voragine, *Legenda Aurea*, 137). The event is, however, reflected in Armenian and Arabic sources of

The situation only deteriorated still further during the following decades. Reportage of events in the Eastern Empire become increasingly confused; one finds, for instance, the *Chronicle of Fredegar* claiming that the Arabs had come from the Caucasus in its incredibly confused account of what might be the Battle of Yarmouk (*Chronicle of Fredegar*, 4.66)⁴⁰.

What was known of Islam in the seventh century west was neither adversarial nor friendly; it was, instead, virtually non-existent. Writers in the West simply do not seem to have known about what had happened in the eastern Mediterranean, barely possessing even garbled accounts. The late seventh century account of a traveller to Jerusalem, Adomnán's *De locis sanctis*, was composed not as a guide to travellers but with the assumption that the reader could never possibly travel there (O'Loughlin, 1992, pp. 37-53). In Bede's reworking of it, just as in Adomnán's original text, there does not appear to have been much awareness of the emergence of Islam or the decline of the Byzantine Empire. They are aware of a 'Saracen king' situated in Damascus and ruling over Jerusalem but, beyond knowing he is neither a Christian nor a Jew (though he recognizes Jesus as 'Saviour of the World')⁴¹ (Adomnán, *De locis sanctis*, 2.11; Bede, *De locis sanctis*, 4), there is no knowledge of the new religion⁴². Yet, after the Muslim invasion and conquest of Spain, Bede wrote an extensive commentary on the Book of Genesis and, when discussing Ishmael, stated:

This means that his [Ishmael's] seed was to dwell in the desert, that is the Saracens, who are without fixed habitations. That they would set upon all the nations and be attacked by all. But this is only the beginning. Now, however, his hand is against all men, and the hands of all are against him, to such an extent that the whole of Africa is in the dominion of their squeezing, and they also hold the greatest part of Asia and some part of Europe, hateful and hostile to all (Bede, *Commentarius in Genesim*, 4, 16:12)⁴³.

the period. That Western chroniclers would have been unaware of what was viewed within the Empire itself as the climax of the struggle suggests that no one was aware of it. While the loss of the Cross was not noted in contemporary sources of East or West (as it would have simply been a small detail in the over-all accounts of the loss of Jerusalem), it appears to have been used as a principle propaganda argument by Heraclius's regime in the period immediately after the end of the Persian War. It is notable that, in the two accounts of Arculf's journey to Jerusalem and Constantinople, neither Bede nor Adomnán are aware of how the Cross came to be in Constantinople. The earliest sure knowledge of the event from Latin sources is from the ninth century (Hrabanus Maurus, *Homiliae*, 70. 131).

⁴⁰ *Chronicle of Fredegar*, 4.66. Almost the only detail he provides that is substantively correct is in identifying Heraclius's biological relationship to the Empress Martina.

⁴¹ Bede, *De locis sanctis*, 4. Adomnán, *De locis sanctis*, 2.11.

⁴² Though they do refer to the existence of a Saracen 'four-sided house of prayer' on the site of the Temple (Adomnán, *De locis sanctis*, 1.1; Bede, 2.3).

⁴³ Bede, *Commentarius in Genesim*, 4, 16:12. «Significant semen eius habiturum in eremo, id est Sarcenos uagos, incertisque sedibus. Qui uniuersas gentes quibus desertum ex latere iungitur incursant, et expugnantur ab omnibus. Sed haec antiquitus. Nunc autem in tantum manus eius contra omnes, et manus sunt omnium contra eum, ut Africam totam in longitudine sua ditone premant, sed et Asiae maximam partem, et Europae nonnullam omnibus exosi et contrarii teneant».

Curiously, this text, usually dated to between 722 and 725 (Kendall, 2008, p. 45), is the very first notice from the British Isles of Islam, despite a century having passed since the Hegira; knowledge of even the emergence of Islam was slow to reach these shores. Even among the Franks, a strong awareness of Islam only emerges after the conquest of Spain. While Fredegar had only a slight awareness that the Arabs are of a different religion, his eighth century continuator had no such confusion and is quite hostile (*Chronicle of Fredegar*, 4.108)⁴⁴. By then, one also finds that the *Apocalypse of Pseudo-Methodius* had been translated into Latin by Petrus Monachus and its extremely hostile reading of the rise of Islam and the imminent end of the world spread rapidly (Beckett, 2003, p. 145)⁴⁵.

Awareness of events in the West also fades from Eastern sources. In the sixth century, Byzantine writers appear to have had regular sources of information from the west. The outlines of Frankish and Visigothic history are obtainable from writers such as Procopius, Agathias, and Menander Protector. Even details of fifth century Western history seem to have been widely known⁴⁶. Early in the century, for instance, Zosimus wrote what remains the fullest description of the end of Roman rule in Britain (*Historia Nova*, 6.1-10). Similarly, Britain was well within Procopius's range of interests. Even if some details confused him when he wrote of Britain, he could claim to have seen Anglo-Saxon warriors as well as having met people who had been to Britain on the docks of Constantinople (Procopius, *De bellis*, 8.20). His Frankish and Spanish information appears to have superior to his British. Procopius's descriptions of Frankish war tactics remain a key source on Merovingian warfare (Procopius, *De bellis*, 8.20)⁴⁷. Similarly, Agathias' descriptions of the Franks appear based on first-hand knowledge (Agathias, *De imperio*, 1.20, 2.5)⁴⁸. Even the Emperor Maurice himself was interested enough in the Franks to describe methods of fighting them (Maurice, *Strategikon*, 11.3). Spaniards, Gauls, and Britons make appearances as visitors to the East in sixth century Christian literature as well; Evagrius, for instance, describes British and Spanish visitors to St. Simeon Stylites on his pillar in rural Syria (Evagrius Scholasticus, *Historia Ecclesiastica*, 1.13). Such contacts continue into the first years of the reign of Heraclius.

From the remainder of the seventh century, though, Greek, Syriac, and Coptic sources have virtually nothing to say about the western lands. An anonymous author writing between 658 and 660 composed a collection of miracle stories related to the cult of the fourth century Saint Artemios of Antioch. Artemios' relics had been transferred to Constantinople and had caused numerous cures, including that of a shipbuilder named Theoteknos who was cured of his afflictions while sailing

⁴⁴ *Chronicle of Fredegar*, 4.108 speaks of 'faithless Saracens' and the role of Christ in giving Charles Martel victory.

⁴⁵ The text appears to have been originally composed in Syriac sometime in the seventh century after 634, then translated into Greek, and the Greek version was used as the basis for the Latin version of which the oldest copies date from the eighth century

⁴⁶ As found in Jordanes, Marcellinus Comes, Procopius, Zosimus, etc.

⁴⁷ Procopius, 6.25, etc.

⁴⁸ Agathias, *De imperio et rebus gestis Iustiniani Imperatoris libri quinque*, 1.20, 2.5, etc.

to Gaul (*The Miracles of Saint Artemios*, Miracle 27). How long before the author's time the voyage had occurred is, however, unclear. The only other mentions that can be found of the British Isles are rather vague and do not suggest any recent knowledge from those lands. Jacob of Edessa (c.640-708) in his Syriac *Hexameron* knows of Hibernia (as "YWB' RNY"), Albion (as "LW'YWN"), and Brettanikoi as islands at the end of the Earth but has nothing beyond their location to say of them (Brock, 1995, p. 52). A more curious mention comes from the *Doctrina Iacobi nuper Baptizati*. While the text contains the first mention of Muhammad and Islam (though not by name) written in any language (*Doctrina Iacobi*, 5.16), it also contains a discussion of the former extent of the Roman Empire, including, Scotia, Britain, France, Italy, Greece and Thrace, as far as Antioch, Syria, Persia, and all the East, Egypt, Africa and the African interior (*Doctrina Iacobi*, 3.10). That, though, was in the past and the loss of those lands is seen as symptomatic of the imminent complete collapse of the Empire and the Apocalypse. Similarly, Arabic sources are silent on these lands even though later tradition attributed awareness of events abroad to Muhammad who is supposed to have said, *Seek knowledge even in China* (Lammens, & Ross, 1926, p. 71)⁴⁹.

The West had receded from being a place to which ships sailed and from which pilgrims – as well as tin and other trade goods – came to be simply a far off distant land, if it was recalled at all. The silence regarding the West was even more complete than the Western lack of knowledge of the Eastern lands. The difference is not hard to understand. The Westerners saw themselves as living on the edge of the world and so they were regarded. They were curious about things at the center even when they were not directly involved. The more centrally located peoples, on the other hand, were only interested in those far away in as much as they impacted upon them. The Byzantines were always focused on one city, Constantinople, and other places, even their own provinces, only mattered if they impacted upon it and its rulers. In the sixth century, Justinian's wars had brought an interest and involvement in things even further west. In the seventh century, what happened north and west of Rome mattered very little. Syriac, Armenian, Coptic, and Arabic writers tended to see the lands of the West from a Byzantine perspective and largely saw events there through a Byzantine lens; if the Byzantines did not think it worth mentioning, they are unlikely to have done so. The West had no special significance in the East, nothing to match the role of the East in the minds, if not the reality, of Westerners.

During the seventh century moved on, less news from the East reached Western ears than in the past or in the following century. Yet, this was a time when the western countries were no longer in cultural decline or even standing still; they were already embarking on new cultural paths and achievements. Trade was expanding and Britons and Franks were going south of the Alps in increasing num-

⁴⁹ A well-known and frequently quoted hadith though, apparently, one of questionable authenticity, even if attested quite early.

bers, if only as far as Rome⁵⁰. They were still hungry for information but it was no longer readily available to them when they reached the Mediterranean.

A desire for knowledge of news from the East remained in the West throughout the seventh century, a desire fuelled by the natural curiosity of learned Christians about the land of origin of their faith and by the tendency of those living in peripheral regions to be keenly interested in the latest news, fashions and gossip from the centre. That desire for news would have been mirrored in other features of the time. Westerners mimicked what they thought were the most up to date trends in the East just as their predecessors had done since before they had been brought into an expanding Roman Empire. Under the Empire, that desire had been expressed in the spread of Latinate high culture and Roman civilization throughout the West as well as the spread of Christianity into those peripheral areas. By the fifth century, the concepts of *Romanitas* and *Christianitas* were seen as being coterminous by most in the Latin West and the two were long used as equivalents (Markus, 1988, pp. 102-103). Post-Roman residents of the West continued to think of themselves as a part of the Roman world, dating chronicles by regnal years of Emperors for centuries after the Empire had ceased to rule in their regions, referring to themselves as Romans, and even raising monuments marking a consul in Constantinople on the shores of the Irish Sea⁵¹. In that vision, whether expressed as Roman or Christian, the peoples of the Atlantic coasts of Europe saw themselves as living far from the centre; like so many peripheral peoples, they possessed a far greater interest in what happened in the centre than those in the centre possessed regarding them.

Yet, when the evidence for contacts between the regions in the seventh century is evaluated, it appears that, while a desire for knowledge of news from the East remained, the fulfilment of that desire had become far less possible. The ‘quality of reporting’ on the East found in the Western sources seems to decline sharply during the seventh century. This strongly suggests that, by the middle of the century, ships were no longer regularly arriving in the Mediterranean ports of Spain and Gaul with the latest news and gossip from Constantinople, Alexandria, and the Levantine ports. Contact had not completely dissolved but it was not what it had been in former times. Instead of maritime trade, it appears that most trade between the Mediterranean and northern Gaul now moved overland via the Col de Montgenèvre and other Alpine passes (Loseby, 2000, p. 179)⁵². Rather than wine, oil, papyrus, and other bulky materials, only relatively light-weight items (such as spices or silks) would have been traded, though slaves might have been walked over the passes.

⁵⁰ Most famously, Wilfrid of Hexham, but also Aldhelm of Sherborne and King Caedwalla of Wessex, while Oswiu of Northumbria intended to go at the time of his death.

⁵¹ The famous Penmachno inscription, which can be read as referring to the consulship of Justin in 540. See Handley, 2001. The inscription might also be derived from the Burgundian system of dating years in the post-consulship of Justin, 540-640.

⁵² This route, via the Po Valley and crossing the Alps at Montgenèvre, had been used in Roman and Ostrogothic periods but had fallen largely out of use in the aftermath of the Lombard invasion.

5. Dating disruption: Numismatic traces

The numismatic record provides further evidence. The presence of – or lack of – Eastern coins on Western sites would, one assumes, mark clearly whether trade and other economic activity persisted. Coins from the Byzantine east could have made their way to the West either through direct exchange – arriving in the purses of merchants coming from the Empire or as subsidies from the Empire – or through exchange carried on between intermediaries, in Italy or elsewhere. Coins might mark trade routes and a distribution of Byzantine coins might mark where ships and traders from the Empire (as well as its successor states) had gone.

Presumably, a significant change in the distribution of these coins in the West should occur around the time posited as being the period of the break in economic ties between the regions (629-655). Interestingly, this may be precisely what happened. Using a list of all Byzantine coin finds in modern France, Switzerland, Germany, the Low Countries, and the United Kingdom (Lafaurie, & Morrisson, 1987, pp. 38-98), a distribution by reign can be developed (table 1).

Tab. 1 *Byzantine coin finds in the West, 491-741.*

Emperor	Dates	Years	Total Coin finds	Coin finds per regnal year
Anastasius	491-518	27	22	0.81
Justin I	518-527	9	17	1.88
Justinian I	527-565	38	73	1.92
Justin II	565-578	13	18	1.38
Tiberius II	578-582	4	7	1.75
Maurice	582-602	20	23	1.15
Phocas	602-610	8	25	3.12
Heraclius	610-641	31	42	1.35
Constans II	641-668	27	12	0.44
Constantine IV	668-685	17	3	0.17
Justinian II	685-711	26	1	0.03
Leo III	717-741	24	1	0.04

The sudden and precipitous drop from the reign of Heraclius is interesting. Unfortunately, many of the types do not allow a closer dating than to the reign of a given emperor so a further narrowing may not be possible. Similarly, while older coins could have remained in circulation long after issue, that few newer ones appeared is arresting.

Even more striking, perhaps, is the apparent lack of coins from the Levant. Official Byzantine issues were being imported into Syria well into the 650's and the locally issued coinage – the so-called 'Arab-Byzantine' issues – followed the declining Byzantine standards closely (as well, of course, as making some attempts to follow the designs) (Foss, 2008, IX-X). Coins and mints proliferated in the Levant after the Islamic conquest with between 30 and 33 different localities issuing coins. The overall impression «leaves little doubt about the active – almost hyperactive –

state of the monetary economy in the seventh and eighth centuries» (Walmsley, 2010, p. 23). However, these are almost entirely inland sites, suggesting major changes in the economy since the sixth century (Walmsley, 2010, p. 24). Only one example of the Arabo-Byzantine coinage (issued until the monetary reforms of Abd'l Malik in 695) has been found in these regions (a dinar minted in Damascus between 640 and 650 and found near Autun) (Lafaurie & Morriison, 1987, 67-68).

Curiously, a precedent to the Arabo-Byzantine issues can be found in the coinage issued in Syria during the Persian occupation. The coins are relatively rare (only around 200 examples are known) (Pottier, 2004, p. 19). Most of these were purchased in Levantine markets so the find sites are largely unknown though they appear to be concentrated in Northern Syria. Probably, most were minted in Homs (Emesa) (Pottier, 2004, p. 98) rather than at Antioch (Pottier, 2004, p. 21). As a group, they are highly erratic in design and have frequent mistakes in mint marks (Pottier, 2004, p. 25). Various emperors appear on them, including Phocas, Heraclius, Justin II, and Maurice. Production was lowest in the first years of the occupation but doubled after 616 and again after 621 (Pottier, 2004, pp. 100-102), suggesting that the monetary economy did not falter and that the coins already in circulation were insufficient for the needs of the economy.

Byzantine coins from the reign of Justinian II were, apparently, one hundred times less likely to be lost in the West than those of Phocasa century earlier⁵³. If commerce were monetized in this period, one might presume that trade had fallen at least as much. Unfortunately, in some regions and periods where we know that some level of exchange with the East occurred, coin finds are almost completely lacking. Ceramics and other imports conclusively show, for example, that the West coast of Britain was in direct contact with the eastern Mediterranean during the sixth century. Yet, coins from that area are almost unknown (Campbell, 2007, pp. 74-76). The British Isles had stopped using coins as a medium of exchange fairly early in the fifth century and coins would not be minted in Britain again until sometime between 570 and 650 (Kent, 1961, pp. 1-22).

Similarly, coins, especially gold ones, appear to have been found in areas where they were not used for monetary exchange but as simply treasure, whether as articles of display or as stock for smithing. Gold coins may have had some sort of ritual significance far beyond their actual monetary circulation. The Sutton Hoo coin-purse may very well be an example of this; the coins could have been intended as an exchange for the services of the rowers on the ship, conveying the deceased to the afterlife (Grierson, 1970, pp. 14-18).

⁵³ The apparent surge of usage in the reign of Phocas might have several possible origins; a statistical fluke could be caused by sheer chance (as the numbers of finds are relatively small); Phocas is known to have had relatively good relations with the Papacy and the coins could reflect sizable gifts sent to Rome; Phocas's regime may have put more of the treasury inherited from Maurice into circulation; imperial subjects might have 'unloaded' unwanted reminders of his reign on westerners; or these might even represent examples of the coinage issued under Persian occupation.

In much of Gaul and Spain, though, coins continued to be minted and, presumably, were used as a medium of exchange to at least some level. In both Frankish and Visigothic realms, the coinage initially conformed to an imperial standard but was later adjusted. From 580 or so, the main gold coin in circulation in the Merovingian realms was the tremissis, valued at a third of the solidus (Harl, 1996, p. 184).

In Gaul, the decline in both quality and quantity of the coinage was steady. At the beginning of the seventh century, the only appreciable differences in quality of coinage were those between mints in the regions with the areas furthest from the Mediterranean having lower amounts of gold in their coins than those in the south. From the beginning of Chlothar II's reign (615), though, the gold coinage began to be steadily debased; the older standards appear to have been abandoned sometime around 638 (Kent, 1972, pp. 69-74). It has been hypothesized that this was due in no small part to a cessation – or at least a significant decrease – in Byzantine subsidies from the massive ones known to have been given in the late sixth century. Gregory of Tours writes of the donation of 50,000 solidi to Childebert by Maurice and the 'gift' was not the only one (Gregory of Tours, *Decem Libri Historiarum*, 6.42). In the seventh century, though, those ample gifts appear to have vanished. Only Dagobert's acquisition of 200,000 solidi from the Visigoths in 631 stalled the decline (Kent, 1972, p. 73).

As the gold, whether from trade or subsidies, would have entered Gaul primarily in Marseille, it was from there that the gold coin issues of the Frankish kings largely emanated. The officials who had been sent to the port were also in charge of the mint and, fortunately, one of them, Eligius, went on to a further career in the Church as Bishop of Noyon (645-660) from which he led the Christianisation of Flanders. These efforts brought him sainthood and caused a hagiographical life to be written about him by Dado of Rouen. Under Dagobert, he had served the crown as master of the mint and coins with his mark survive. Interestingly, his *vita* informs us of how he was able to 'stretch' gold, something that fits with the increasing scarcity of the metal.

Similar series continued after his time with a steady decrease in gold content. The precious metal was increasingly rare and the last gold coins to be minted in Gaul were issued in Marseille around 670. By then, gold coins had been largely abandoned in favour of silver throughout the Merovingian sphere (Metcalf, 1972, p. 401). The new silver coinage was also being used in England and its spread appears to be linking to the growth of the North Sea economic system and the new emporia around it. Gold was no longer coming into the region as trade as well as gifts and subsidies had stopped flowing from the gold rich economies of the eastern Mediterranean. The close match between numismatic and literary evidence is striking in its suggestion of when the former Mediterranean economy finally broke down.

These coins' patterns can be further amplified with data from within the Empire. Byzantine copper coinage, after a long period of stability with a follis of eleven grams, had a marked collapse during the reign of Heraclius. In the sixth regnal year of Heraclius (615-6), the follis dropped to between eight and nine grams be-

fore, during his fifteenth year (624-625) declining to just above five grams. In Heraclius's twentieth and twenty-first years (629-631), the old weight of eleven grams was restored temporarily before again falling to five grams for the rest of his reign (Hendy, 1985, p. 498). Similarly, Heraclius had been forced to issue a new silver coinage, the hexagram, during the worst years of the early part of his reign (from 615), minted from plate donated by the Church. That coinage disappeared by the reign of Justinian II (Grierson, 1999, pp. 12-13).

In contrast to what went on with the Frankish coinage during the seventh century, the fineness of Byzantine gold coins minted in Syracuse and Constantinople itself did not decline in this period, remaining nearly (98%) pure throughout the century (though some issues minted at Syracuse under Justinian II in 695 had a notably lesser - 80% - fineness) (Morrisson, Barrandon, & Poirier, 1983, p. 280). The close dating of that decrease to the vicissitudes of Byzantine Africa may be coincidental but it is striking that such coins appear not to have been reaching Marseille.

6. A new model of decline and collapse

Taken together, these disruptions in the supply of coinage, gold, papyrus, oil, and wine, as well as the rupture in the flow of information, point to several stages of decline in the former Mediterranean trading community. These can be seen as occurring at or around 615 (when the supply of eastern gold begins to falter) and between 628 and 631 (when there is a break in the spread of knowledge of current events from the East as well as the beginning of the precipitous decline of Merovingian gold supplies) followed by a degree of stabilisation until around 670 (when the arrival of new gold and papyrus into Gaul appears to cease) with a final collapse occurring at the very end of the century (when the last imports of African ceramics vanish from European sites). After the turn of the century, information from the eastern Mediterranean only begins to revive with the establishment of Islamic rule in Spain; it is even later that gold and other materials again begin appearing in Francia and Britain, in the period after 750.

What had happened? If Pirenne were to be believed, the precipitating crisis for the disappearance of trans-Mediterranean trade was the Islamic Conquest. Yet, the dating of the collapse does not neatly follow any logic following from that. The first stages of decline – those dated to 615 and 628-631 – occurred before the first Muslim armies had begun their expansion into the territory of the Empire while the other two dates (of 670 and 695-700) occur well after the most dramatic stages of the conquest had occurred. The restoration of trade and the resumption of contact in the eighth century would, if anything, appear to have been encouraged by the conquest of the Visigothic kingdom in 711-712 and the success of the Abbasid revolution at mid-century.

But, while clearly showing the break and, perhaps, dating it to the years between 615 and 640, such evidence does not explain an end to communications.

Private individuals in Gaul, whether churchmen returning from the East or the Syrian merchants beloved by Pirenne, ought to have known details of current events in the East and that knowledge should have left some traces. Instead, what was known was fractured and flawed. Trade had withered and ships landing at Marseille and elsewhere on the western shores of the Mediterranean became rarer and, with fewer ships, less news and fewer coins came from the East.

Political changes and wars could have disrupted the networks of trade that had existed at the beginning of the century. Yet the collapse of the contacts was more complete than would seem likely without an effective embargo. During the wars with the Persians and with the Avars, the Byzantines had remained masters of the sea. Their fleets had been practically unchallenged in the Mediterranean since, at least, the re-conquest of Carthage early in Justinian's reign. The whole success of the resurgence of the Empire and its defeat of Persia were premised on a level of naval supremacy that enabled Heraclius and his army to land far to the rear of the Persian front and effectively prevented meaningful coordination between Persians and the Avars. When the Arab invasions happened, again, the Byzantines initially had unchallenged control of the sea. Without that, they would not have been able to retake Alexandria briefly in 645-6. It was only in the following year that Muawiya's attempts to build a fleet paid off when, at the Battle of the Masts off the Lycian coast (Theophanes, AM 6146), the Roman fleet was defeated⁵⁴. It was in the context of that defeat that Fredegar had written of the end of the Empire (*Chronicle of Fredegar*, 4.81). Yet, the fleet remained vital and its west Mediterranean squadrons appear to have been unchallenged right up until the very end of the century. Carthage and other North African harbours remained in Byzantine control long after most of the interior had passed into Muslim hands⁵⁵. Byzantine fleets might even raid as far as the coasts of Spain (*Chronicle of 754*, 87.1)⁵⁶.

A simple military explanation of the lack of communications thus seems unwarranted. Henri Pirenne suggested that it was the threat of Arab piracy that caused the collapse of Marseille's fortunes (Pirenne, 1954, p. 248) but that seems, at best, to only give a fraction of the story and to be far too glib. One reads, for instance, that Pope Stephen II sailed to Marseille in 756 (*Liber Pontificalis*, 94.43), at a time when Pirenne would have us believe the seas were full of Saracen corsairs and hardly safe for anyone, let alone the head of the Catholic Church (Pirenne, 1925, p. 30). So, Pirenne's notion that Arab piracy and raiding broke the unity of the Mediterranean is mistaken. The first Arab fleet only appeared after the lines of communication had broken down; the Byzantine fleet remained a major force throughout the Mediterranean long afterwards; Arab naval activity cannot be seen as causative for these first decreases in shipping.

⁵⁴ The first naval defeat since the Vandal's defeat of the fleet of Heraclius of Edessa in 468.

⁵⁵ Carthage was conquered by the Arabs in 695 but was retaken by a naval expedition sent by Leontius in 697 and finally lost in 698. See Theophanes, AM 6190 for the expelled fleet's subsequent rebellion.

⁵⁶ *Chronicle of 754*, 87.1, reports a Byzantine naval raid during the reign of Wittiza (694-702/3).

Instead, it seems more likely that the breakdown in communications had already happened in the decades before the Battle of the Masts. Other evidence points in the same direction. In the sixth century, the Frankish Church had held regular Pan-Gallic councils (Wallace-Hadrille, 1983, pp. 94-106). Those had ceased to function in the latter part of the seventh; in 742, Boniface could claim to the Pope that there had been no councils in eighty years (Wallace-Hadrille, 1983, p. 107). At the same time, the Frankish kingdoms appear to have grown weaker and all of the Merovingian states experienced disintegration.

By then, the great trade was long dead. Cities that had relied on it, like Marseille, had shrunk greatly and, in place of fine wines and spices served on imported pottery from the whole Mediterranean, their diminished population used coarse local wares and drank poorer local vintages. The ships that once had brought trade from the East had stopped coming; regardless of whether or not there was still demand in Gaul for the things they had brought⁵⁷, they were gone. As those ships had merely visited ports like Marseille and had not belonged to the Masillians or other Westerners, the collapse of trade was entirely driven by their absence.

They had come west for slaves and that need disappeared during the course of the seventh century. Perhaps the wars of the Byzantines, whether with the Persians or the Muslims, had a significant effect on the drying up of trade. Egypt, the Levant and Anatolia had long been the economic powerhouses of all of western Eurasia (Wickham, 2009, p. 362). While the Western Roman Empire had gone into political and economic decline, those regions had seen their economies boom (Wickham, 2005, p. 27). Now, though, they were invaded, occupied and ravaged by decades of war. Rather than being economic engines that drew exports of raw material from the periphery, they were in economic decline. The goods that they had traded for in the west, whether wood, tin, or human slaves, were no longer needed in such abundance. So, the merchants of the East sailed less and less to the west. News along with gold and all the products of the East were no longer carried on those ships.

Meanwhile, the demand for slaves in the East would, increasingly in the years after 610, have been met from local sources. The Persians took large numbers of Byzantines as captives, such as the reported many tens of thousands captured in 611 in Cappadocia (Theophanes, AM 6103), ‘multitudes’ from Damascus (Theophanes, AM 6105), or the large number taken from Jerusalem, including the Patriarch, and transported to Persia⁵⁸. Defeated soldiers on both sides would have often been sold as slaves. When the tide of war turned in favour of the Empire, the peoples of the Persian Empire would have found themselves captured and enslaved by the victors, whether the Byzantines themselves or the Gökturks who ravaged the

⁵⁷ The demand was certainly there; the North Sea emporia were expanding rapidly at this time while the desire for products like papyrus and olive oil remained after they were no longer available.

⁵⁸ Theophanes, AM 6106. Theophanes claims 90,000 Jerusalemites were killed, including many who had been purchased by the Jewish community for the purpose of execution. Sebeos (69) gives a figure of 57,000 dead.

northern parts of the Sassanid realm. The wars of the Islamic unification of Arabia and expansion beyond it similarly resulted in further massive increases in slaves.

The Islamic conquests involved, if anything, even more enslavements than had the Persian Wars. Certainly, the occasional numbers found in the sources suggest a truly massive number of people were taken into slavery (or, if already enslaved, found themselves with new masters). Even if the numbers are exaggerated, they must reflect a reality. During the initial campaigns against the Roman and Persian Empires, for instance, sometimes entire communities were enslaved, as happened to much of the population of the Mesopotamian Sawad⁵⁹ (including the Arab supporters of the Persians)⁶⁰ (Al-Tabari, 2042) as well as to cities such as the Palestinian capital of Caesarea whose inhabitants were taken to Hijaz after its capture (Al-Tabari, 2398) or in Egypt, where, we are told, the women and children of cities such as Kilunas that resisted were taken off as captives and divided among the conquerors after the men were all slain (Al-Tabari, 2581-2583, 2589-2590; John of Nikiu, 119.12)⁶¹.

Further wars brought even more slaves and slave-trading itself often became the chief purpose of warfare, as, for instance, in the annual campaigns waged from northern Syria against the Byzantine Empire (Theophanes, AM 6142, 6154)⁶². Sometimes, the numbers are quite astonishing: an inscription found at Soloi in Cyprus testifies to the Arab capture and removal of 120,000 people during Mu'awiya's great raid of 649 (Gagniers, & Hinh, 1985, pp. 115-126). The North African campaigns as well as the other wars of the Umayyad period saw even more people enslaved and many of them were exported back to the core territories of the growing empire (Theophanes, AM 6161)⁶³. Normal practice was for a large share of the slaves and other booty to be handed over to the state with the remainder divided up among the commanding generals and their followers. After the conquest of the Visigothic kingdom, for instance, sixty thousand prisoners were handed over to the Caliphal authority as slaves, forming one fifth of the total number of captives (Ibn al-Ather, 4.112). At that same time, Musa ibn Nusayr himself is said to have returned to the East with thirty thousand enslaved virgins from the defeated Visigothic aristocracy (Ibn al-Ather, 4.124)⁶⁴.

⁵⁹ Al-Tabari, *Tarikh al-rusul wa al-Muluk*, 2025, 2029, 2031, 2032, 2036, 2042, 2045, 2066, 2072, 2073, 2077, 2122, 2170, 2198, 2205, 2207, 2440, 2464, 2465, all testify to the capture and enslavement of both defeated soldiers and civilians during the conquest of Iraq. Tabari, writing in Abbasid Iraq, was far more concerned with the details of the conquest there and in his native Iran than in other regions.

⁶⁰ Al-Tabari, 2042, quotes ibn Buqaylah as mourning the defeat of the Arabs of al-Hirah saying: 'The tribes from Ma'add divide us up openly like the shares of a slaughtered beast'.

⁶¹ John of Nikiu, 119.12. Al-Tabari, 2581 - 2583, 2589 - 2590, refers to captured Egyptians taken into slavery in Arabia.

⁶² Theophanes, AM 6142, gives 5.000 prisoners as being taken from Isauria; AM 6154, refers to many captives

⁶³ Theophanes, AM 6161, states that, during the second invasion, 80.000 Africans were taken away as captives.

⁶⁴ Ibn al-Ather, 4.124; Ibn Qutiyya writes that Musa set off for Syria accompanied by a mere four hundred prisoners of noble birth, wearing gold crowns and belts (Tarikh, 53).

While these numbers may be doubtful⁶⁵, they probably do express something of the sheer massiveness of the number of captives entering slavery in the period. Slaves became massively cheap in the aftermath of these wars, much as they had done during the period of Roman expansion. Slave labour overwhelmed free in many places while the flood of slaves from the new conquests meant that formerly profitable commerce became unnecessary. Merchants no longer needed to sail across the seas to foreign ports to bring back slaves to North Africa, Egypt, or the Levant. Instead, the new rulers were overwhelmed by the sheer numbers (Shaban, 1971, p. 47). A property owner in Syria or Egypt would be unlikely to have purchased slaves imported from the far west when captives from the near constant raiding and campaigning across the frontiers in Anatolia and the Caucasus were readily available. The same situation also affected the more impoverished Byzantine side of the frontier; they used war captives as forced labour from the same regions in addition to the large numbers of Slavic captives from the Balkans who were sent to Anatolia⁶⁶.

Such economic activity as was carried out by the peoples of the eastern Mediterranean was increasingly into new markets rather than to the west. Trade south and eastwards increased as the frontiers between Roman and Sassanid Empires vanished and the merchants of Mecca became rulers of a vast empire (Brown, 1971, p. 196). New sources of raw materials came into use and new lands entered intense cultivation in southern Mesopotamia (Wickham, 2009, p. 361). In that region, large numbers of East African slaves were already being imported by the end of the century; a slave rising near Basra in 694 was led by an East African slave named Ribah (Shaban, 1971, p. 106)⁶⁷. Elsewhere, a new slave trade developed out

⁶⁵ Transporting three hundred thousand – or even thirty thousand – slaves from Spain would necessitate a sea journey. While the Muslims definitely possessed or could acquire a large amount of shipping by the early eighth century, the size of ships cannot be imagined as incredibly large yet, even if it were, an enormous number of separate voyages would need to be made from Spain. Assuming a single ship could carry an astounding 300 slaves, a thousand voyages of these very large ships would be required. This raises the immediate question of what was being carried on the same ships when they arrived in Spain. As the total number of Arab and Berber settlers in Spain is far smaller than the number of slaves said to have been exported, it is unlikely that the slaves could simply have been sent on returning transport bound for North Africa or elsewhere.

⁶⁶ E.g., see Theophanes, AM 6149, mentions large numbers of Slavic prisoners from Constans II's Balkan campaign while, under AM 6156, he refers to a group of 5,000 Slavs fleeing to Syria and joining the Arabs. Byzantine seals from 694 and 695 attest to the sale of large numbers of Slavic slaves (Oikonomidès, 1986).

⁶⁷ The East African slave trade to the Persian Gulf had been in existence for some time: The *Periplus of the Erythraean Sea* (Περίπλους τῆς Ἐρυθρᾶς Θαλάσσης), 13, (probably dating to between the first and third century) refers to a town called Opone (probably located on the coast of modern Somalia) that exports «better slaves, which are brought to Egypt in increasing numbers» (δουλικά κρείσσονα, α εἰς Αἴγυπτον προγοῦρει μάλλον). It is just north of the region that the author refers to as Azania, probably the same name as the Arabic Zanj. Cosmas Indicopleutes's *Christian Topography* (Χριστιανικὴ Τοπογραφία), 2.64, written during the reign of Justinian I, similarly refers to a traffic in slaves from the farthest reaches of Ethiopia via the Red Sea to Egypt. There is also some extremely

of Nubia; after a rather obscure campaign against Maqqaria in 651, a treaty was made whereby they provided the Muslims with four hundred slaves annually (Al-Hamdani, *Kitab al-Buldan*, p. 74). From the province of Khurasan even after its conquest, an annual tribute of two thousand slaves was levied (Al-Hamdani, *Kitab al-Buldan*, p. p. 297), while the Khazars and Armenians each provided more than one thousand slaves each year (Al-Baladhuri, *Futuh al-Buldan*, 245).

Clearly, the evolution of the new system in the east Mediterranean meant that far fewer ships came west as far as Carthage after the collapse of Byzantine rule in Egypt and the Levant. Yet, Byzantine North Africa itself remained one of the most prosperous and stable regions of the Empire in this period. Its peace and prosperity, along with that of the neighbouring island of Sicily, allowed it to be used by Heraclius as the base for his rebellion as well as for the ultimately successful war against the Persians. However, after the loss of Egypt to the Empire in 641, the situation of the North African provinces rapidly deteriorated. Gregory, the Exarch of Carthage, revolted against the Empire in 646 and set himself up as an independent Empire. Hardly had he done so than the first major Arab raid beyond Egypt was undertaken and reached as far as central Tunisia. There, in 647, Gregory was slain though the invaders swiftly retreated to Egypt. Though the Islamic conquest of North Africa only began in earnest in 663, Byzantine pre-eminence had been shattered and many of the Berber groups began to act in an increasingly independent manner. Warfare became endemic over the course of the remainder of the century and, after the Arabs established themselves on a more permanent basis, North African captives began to be taken eastward in great numbers. Certainly, the price of slaves in North Africa must have collapsed just as, earlier in the seventh century, the wars between Byzantines, Persians, and Arabs must have flooded the markets further east (Savage, 1992, pp. 356-358).

The first step towards the conquest of North Africa for the invaders had been the subjugation of the Garamantes. This group, living in the semi-desert south of Tripolitania, had been independent of the Empire though had recently Christianised and controlled such trans-Saharan trade as existed at the time. When the Garamantes were subjugated (666-667), their communities were made to pay an annual tribute in slaves. The people of the oases of Waddan (Ibn Abd al-Hakam, *Futuh Misr*, 194.7)⁶⁸, Germa⁶⁹, and Kawar⁷⁰ each agreed to provide 360 slaves per year as tribute. Their own population being quite small, it is unlikely that the slaves that the Garamantes were expected to provide came from their own population. Instead, it appears much more likely that these slaves were brought north from regions on the

circumstantial evidence to the presence of East African slaves in China as early as 463 as well as fairly clear evidence of their arrival by sea by the late Umayyad period (Hsing-lang, 1930).

⁶⁸ Abd al Rahman ibn Abdallah ibn Abd al-Hakam, *Futuh Misr*, 194.7.

⁶⁹ See Ibn Abd al-Hakam, 195. Germa (or Jarma) was the largest town of Fezzan and location of the royal capital of the Garamantes.

⁷⁰ See Ibn Abd al-Hakam, 195. Kawar was at the extreme southern edge of the desert, in the northeast of modern Niger.

far side of the Sahara and the agreements are among the earliest evidence for the export of black Africans (though the agreements suggest that the trade was already in existence at the time).

The Arab conquest of North Africa was what had finally broken the Mediterranean trade. They had slowly pushed the Byzantines out of the interior of North Africa during the last decades of the seventh century, leaving the Empire holding only a few towns on the coast; it is significant that the later dates – 670 and 695-700 – related to the decline of Mediterranean trade match closely with significant events in Africa. Even while Byzantine Africa shrank, it still had a functioning economy and some trade continued with Gaul and Italy. After the Arabs had established a permanent base at Kairouan in 670, though, they lost their hinterlands and were finally over run⁷¹. But, once Carthage and the other African ports had passed into Arab hands, unlike the ports of the Levant, their trade was not able to reassert itself and the cities themselves withered (Kaegi, 2010, p. 249)⁷². Rather than being used as a base for disrupting the sea-lanes leading to Gaul, it seems more likely that any surviving North African shipping would have been blocked by Byzantine fleets; Sicily, Sardinia and southern Italy long remained in Byzantine hands and would have effectively stopped any attempts at trade between Gaul and Africa.

Despite such challenges, though, trade would likely have continued had the desire for it remained in the hands of those controlling shipping. Few blockades have ever been effective and would only have increased potential profits had the merchants desired it. The products of the eastern Mediterranean and North Africa were still desired in Gaul so it was not a lack of demand for them that stopped the ships from coming; rather it would seem to have been a lack of demand for what Gaul had to offer. That can only have been slaves and slaves were, during the years when the trade collapsed, available in enormous numbers far closer than Gaul. It was this lack of demand more than anything that killed the trade.

The slave trade that was the lifeblood seems to have vanished and, when it began to revive in the eighth century, new markets had begun to emerge. First and foremost, of those would appear to have been Venice, which, at exactly that time, began to develop as the premier port linking northern Europe to the Mediterranean (McCormick, 2002, p. 39). Other towns also emerged; Amalfi in Italy also seems to have developed in these years (Citarella, 1968, p. 536). Both Amalfi and Venice grew as ports exporting slaves southward and eastward, to both the Byzantine Empire and the Islamic states (Citarella, 1968, p. 538; McCormick, 2002, pp. 46-51). Unlike Marseille, though, they did not wait for the ships to come from the east. Instead, they built their own boats and took their products to the buyers and, be-

⁷¹ Carthage was conquered by the Arabs in 695 but was retaken by a naval expedition sent by Leontius in 697 and finally lost in 698. See Theophanes, *Chronographia*, AM 6190 for the expelled fleet's subsequent rebellion.

⁷² Carthage itself was all but abandoned when the Arabs finally captured it. Its former satellite of Tunis took its place. Tunis was selected by the new Arab rulers as it was far more defensible from sea-borne attack than Carthage was.

cause of that crucial difference, they, and not Marseille, were responsible for the revival of European trade.

This caesura in trade, caused first by the wars between Byzantines and the Persians and then compounded by the advance of the Arabs, is what we find reflected in the sources and is what causes the lack of reliable news from the East reaching the west. It – not piracy, not the rise of a new religion, not even the wars themselves – is what makes this period the ‘end of the ancient world.’ That world had been premised on the Mediterranean as the route of commerce and the maker of unity. So long as ships sailed regularly from one end of the sea to the other, so long as the peoples of the West had things that the people of the East wanted, that world would continue, regardless of the political surface events. The seventh century, though, saw a break in the *longue durée* and, when trade revived around the sea, the regions had gone far enough down their paths of separate development as to have lost their former civilizational unity.

To sum up, the economic break between the Mediterranean world of antiquity and that of the Middle Ages occurred in the second quarter of the seventh century. That rupture began before the Islamic expansion and continued during it; it cannot have been caused by it. Instead, the break was caused by a significant drop in trans-Mediterranean trade. That drop occurred because of a change in the local supply and demand for captive human beings, that is slaves, in the eastern Mediterranean region due to the impact of the wars of the early and middle seventh century and the consequent overabundance of cheap, local slaves there. Eastern merchants had previously sought slaves in Gaul and elsewhere in Western Europe but no longer needed to do so. As long-distance shipping was overwhelmingly in the hands of Easterners, when they no longer had need of the primary Western export, trade collapsed and with the collapse of trade, civilizational ruptures emerged and grew. When the demand for Western slaves finally re-emerged in the second half of the eighth century, a new economic cycle began as now the Westerners themselves carried their human products to the eastern markets.

*Appendix**Gregorii I papae Registrum epistolarum IX, 105*

Cognoscentes, qualis fraternitatem uestram zelus pro christianis mancipiis, quae Iudaei de Galliarum finibus emunt, accenderit, adeo nobis sollicitudinem uestram placuisse signamus, ut inhibendos eos ab huius modi negotiatione nostra etiam deliberatio iudicaret. Sed Basilio Hebraeo cum aliis Iudaeis ueniente comperimus hanc illis a diuersis iudicibus reipublicae emptionem iniungi atque euenire, ut inter paganos et Christiani pariter comparentur. Unde necesse fuit ita causam ordinatione cauta disponi, ut nec mandantes frustrari nec hi qui contra uoluntatem suam se iniquiunt oboedire aliqua sustineant iniuste dispendia. Proinde fraternitas uestra hoc uigilanti sollicitudine obseruari ac custodire prouideat, ut reuertentibus eis de praefata prouincia christiana mancipia, quae ab ipsis adduci contigerit, aut mandatoribus contra dantur aut certe christianis emptoribus intra diem quadragesimum ueniant. Et transacto hoc dierum numero nullum apud eos quolibet modo remaneat. Si autem quaedam ex eisdem mancipiis talem aegritudinem fortassis incurrerint, ut intra statutos dies uendi non ualeant, adhibenda sollicitudo est, ut, dum saluti fuerint pristinae restituta, similiter modis omnibus distrahantur, quia rem quae culpa caret ad damnum uocari non conuenit. Quoniam uero, quotiens nouum quid statuitur, ita solet futuris formam imponere, ut multa dispendiis praeterita non condemnet, si qua apud eos mancipia de emptione anni praeteriti remanserant uel a uobis nuper ablata sunt, dum apud uos sunt posita, ea habeant alienandi licentiam, ne detrimentum ante prohibitionem possint ignorantes incurrere, quod eos postmodum dignum est uetitos sustinere.

Recognizing that, my brother, your zeal has been lit for the Christian slaves whom the Jews buy from the Gauls, so your solicitude will be pleased that we have signed a judgment that they are inhibited such as forbidding them from even considering trading in this manner. But we have learned from Basil the Hebrew, who came along with other Jews, that this business is commanded them by diverse judges of the republic, as they are placed equally between Christians and pagans. Hence it was necessary that the business be disposed, as to not frustrate the instructions that they were not forced to so against their will nor that they should unjustly sustain any losses. Accordingly, my brother, your anxiety is observed and so keep a vigilant look out, that when they return from the said province, any Christian slaves which they happen to be brought be either handed over to those who gave the order, or, at least, they sell them to Christians by the fortieth day. And after the performance of this number of days let none in any way remain with them. But if some of the slaves fall into such distress, perhaps, to within the stated time they may not be sold, concern should be given that, when they are restored to health, they should be sold the same in every way, that no one who is without blame for

the loss shall not be fit to be called. But since, as often as it is ordained to something new, so it is wont to impose on the form for the future, and the past not to condemn, that many losses, if there be any slaves among them, were left out of the purchase of the past year or had recently been taken away by you from them, let them have liberty to dispose of them while they are with you. So may there be no possibility of their incurring loss for what they did in ignorance before the prohibition, such as it is right they should sustain after they have been forbidden.

References

- Beckett, K.S. (2003). *Anglo-Saxon Perceptions of the Islamic World*. Cambridge: Cambridge University Press.
- Bertelli, C. (1998). The Production and Distribution of Books in Late Antiquity. In R. Hodges, & W. Bowden, (Eds.), *The Sixth Century: Production, Distribution, and Demand*. Leiden: Brill.
- Bischoff, B. (1986). *Latin Palaeography: Antiquity and the Middle Ages*. Cambridge: Cambridge University Press.
- Brock, S. (1995). The Syriac Background. In M. Lapidge (Ed.), *Archbishop Theodore: Commemorative Studies on his Life and Influence*. Cambridge: Cambridge University Press.
- Brown, P. (1971). *The World of Late Antiquity*. London: Thames and Hudson.
- Campbell, E. (2007). *Continental and Mediterranean imports to Atlantic Britain and Ireland, AD 400-800*. York: Council for British Archaeology.
- Citarella, A.O. (1968). Patterns in Medieval Trade: The Commerce of Amalfi before the Crusades. *Journal of Economic History*, 28(4). 531-555.
- des Gagniers, J. & Hinh, T.T. (1985). *Soloi: Dix campagnes de fouilles (1964-1974)* (Vol. 1). Québec: Université Laval.
- Foss, C. (2008). *Arab-Byzantine Coins: an introduction, with a catalogue of the Dumbarton Oaks collection*. Washington: Dumbarton Oaks
- Fouracre, P. (1995). Eternal light and earthly needs: practical aspects of the development of Frankish immunities. In W. Davies, & P. Fouracre, (Eds.), *Property and Power in the Early Middle Ages*. Cambridge: Cambridge University Press.
- Fouracre, P. (1995). Eternal light and earthly needs: practical aspects of the development of Frankish immunities, In W. Davies & P. Fouracre (Eds.), *Property and Power in the Early Middle Ages*. Cambridge: Cambridge University Press.
- Gonzalez, T. (1979). La Iglesia desde la conversión de Recaredo hasta la invasión arabe. In R. G. Villoslada (Ed.), *Historia de la Iglesia en España*. Madrid: BAC.
- Graus, F. (1961). Die Gewalt Bei Den Anfängen Des Feudalismus und die "Gefangenenbefreiungen" der Merowingischen Hagiographie, *Jahrbuch für Wirtschaftsgeschichte*, 2(1). 61-156.
- Grierson, P. (1970). The Purpose of the Sutton Hoo Coins. *Antiquity*, 44. 14-18.
- Grierson, P. (1999). *Byzantine Coinage*. Washington D.C, MD: Dumbarton Oaks.
- Handley, M. (2001). The origins of Christian commemoration in late antique Britain. *Early Medieval Europe*, 10(2). 192-194.
- Harl, K.W. (1996). *Coinage in the Roman Economy, 300 BC to AD 700*. Baltimore, MD: Johns Hopkins University Press.
- Hen, Y. (1995). *Culture and Religion in Merovingian Gaul, AD 481 – 751*. Leiden: Brill.
- Hendy, M.F. (1985). *Studies in the Byzantine Monetary Economy, c. 300 – 1450*. Cambridge: Cambridge University Press.
- Hitchner, R.B. (1992). Meridional Gaul, trade and the Mediterranean economy in Late Antiquity. In J Drinkwater. & H. Elton (Eds.), *Fifth-century Gaul: a crisis of identity?*. Cambridge: Cambridge University Press.

- Hitchner, R.B. (1992). Meridional Gaul, trade and the Mediterranean economy in Late Antiquity. In J. Drinkwater, & H. Elton, (Eds.), *Fifth-century Gaul: a crisis of identity?* Cambridge: Cambridge University Press.
- Hsing-Lang, C. (1930). The Importation of Negro Slaves to China Under the Tang Dynasty (A. D. 618-901). *Catholic University of Peking Bulletin*, 7, 37-59.
- Kaegi, W.E. (2010). *Muslim expansion and Byzantine collapse in North Africa*. Cambridge: Cambridge University Press.
- Kendall, C.B. (2008). *Bede: On Genesis*. Liverpool: Liverpool University Press.
- Kent, J. (1961). From Roman Britain to Anglo-Saxon England. In R.H.M. Dolley, (Ed.), *Anglo-Saxon Coins: Studies Presented to F. M. Stenton on the Occasion of His 80th Birthday, 17 May 1960*. London: Methuen.
- Kent, J. (1972). Gold Standards of the Merovingian Coinage. In E.T. Hall, & D.M. Metcalf, (Eds.), *Methods of Chemical and Metallurgical Investigation of Ancient Coinage*. London: Royal Numismatic Society.
- Lafaurie, L., & Morrisson, C. (1987). La pénétration des monnaies byzantines en Gaule mérovingienne et visigotique du VI^e au VIII^e siècle. *Revue numismatique*, 29, 38-98.
- Lammens, H. & Ross, E.D. (1926). *Islam: beliefs and institutions*. London: Methuen.
- Levillain, L. (1944). Études mérovingiennes. La charte de Clothilde (10 mars 673). *Bibliothèque de l'École des Chartes*, 105, 5-48.
- Lewis, A. R. (1951). *Naval Power and Trade in the Mediterranean, AD 500 – 1100*. Princeton, NJ: Princeton University Press.
- Liphshitz, N., G. B. G., Bonani, G., & Wolfli, W. (1997). Comparative Dating Methods: Botanical Identification and C-14 Dating of Carved Panels and Beams from the Al-Aqsa Mosque in Jerusalem. *Journal of Archaeological Science*, 24, 1045–1050.
- Loseby, S. (2000). Marseille and the Pirene Thesis, II: Ville Morte. In I.L. Hansen, & C. Wickham, (Eds.), *The Long Eighth Century: Production, Distribution, and Demand*. Leiden: Brill.
- Markus, R.A. (1988). The Latin Fathers. In J.H. Burns, (Ed.), *The Cambridge History of Medieval Political Thought, c. 350-c. 1450*. Cambridge: Cambridge University Press.
- Mayerson, P. (1985). The Wine and Vineyards of Gaza in the Byzantine Period. *Bulletin of the American Schools of Oriental Research*, 257, 75-80.
- McCormick, M. (2001). *Origins of the European Economy: Communications and Commerce, AD 300 – 900*. Cambridge: Cambridge University Press.
- McCormick, M. (2002). New Light on the 'Dark Ages': How the Slave Trade Fuelled the Carolingian Economy. *Past and Present*, 177, 17-54.
- Metcalf, D.M. (1972). Analyses of the Metal Contents of Medieval Coins. In E.T. Hall, & D.M. Metcalf (Eds.), *Methods of Chemical and Metallurgical Investigation of Ancient Coinage*. London, Royal Numismatic Society.
- Morrisson, C., Barrandon, J.N., & Poirier, J. (1983). Nouvelles recherches sur l'histoire monétaire byzantine: évolution comparée de la monnaie d'or à Constantinople et dans les provinces d'Afrique et de Sicile. *Jahrbuch der Österreichischen Byzantinistik*, 33, 267-286.
- O'Loughlin, T. (1992). The exegetical purpose of Adomnán's *De Locis Sanctis*. *Cambrian Medieval Celtic Studies*, 24, 37–53.
- Oikonomides, N. (1986). Silk Trade and Production in Byzantium from the Sixth to the Ninth Century: The Seals of Kommerkiarioi. *Dumbarton Oaks Papers*, 40, 33-53.
- Parker, A.J. (1992). *Ancient Shipwrecks of the Mediterranean and the Roman Provinces*. Oxford: Tempus Reparatum.
- Pirenne, H. (1925). *Medieval Cities: Their Origins and the Revival of Trade*. Princeton, NJ: Princeton University Press.
- Pirenne, H. (1954). *Mohammed and Charlemagne*. London: G. Allen and Unwin.
- Pottier, H. (2004). *Le Monnayage de la Syrie sous l'occupation Perse (610 – 630)*, Paris: Cahiers Ernest-Babelon.
- Richard Hodges, R. (1989). *The Anglo-Saxon Achievement*. London: Duckworth.

- Savage, E. (1992). Berbers and Blacks: Ibādī Slave Traffic in Eighth-Century North Africa. *Journal of African History*, 33(3). 351– 368.
- Scheidel, W. (2010). The Roman slave supply. In K. Bradley, & P. Cartledge, (Eds.) *The Cambridge World History of Slavery* (pp. 287–310). Cambridge: Cambridge University Press.
- Shaban, M.A. (1971). *Islamic History: A New Interpretation, 1 AD 600-750 (AH 132)*. Cambridge: Cambridge University Press.
- Thompson, E.A. (1952). Peasant Revolts in Late Roman Gaul and Spain. *Past & Present*, 2. 11-23.
- Thompson, E.A. (1956). The Settlement of the Barbarians in Southern Gaul. *The Journal of Roman Studies*, 46(1-2). 65-75.
- Thompson, E.A. (1977). Britain, A. D. 406-410. *Britannia*, 8. 303-318.
- Wallace-Hadrill, J.M. (1983). *The Frankish Church*. Oxford: Clarendon Press.
- Walmsley, A. (2010). Coinage and the Economy of Syria-Palestine in the Seventh and Eighth Centuries CE. In J. Haldon, (Ed.), *Money, power and politics in early Islamic Syria: a review of current debates*. Farnham: Routledge.
- Wander, S. H. (1975). The Cyprus Plates and the *Chronicle* of Fredegar. *Dumbarton Oaks Papers*, 29. 345-346.
- Wellhausen, J. (1963). *The Arab Kingdom and its Fall*. Beirut: Khayat.
- Wickham, C. (2005). *Framing the Early Middle Ages: Europe and the Mediterranean, 400-800*. Oxford: Oxford University Press.
- Wickham, C. (2009). *The Inheritance of Rome: A History of Europe from 400 to 1000*. London: Penguin.

*A Kingdom of Silk:
The Genoese as Artisans, Merchants, Bankers, 1450-1650**

CÉLINE DAUVERD

*Viene il Greco, Il Tedesco, e vien l'Inglese,
L'Alemanno e il Francese,
Il Pugliese, Abruzzese e Calabrese,
Non dico il Fiorentin nè il Genovese,
Che stan così in arnese
Che non voglion tornar più nel paese.
Ma il Turco, il Moro e l'Indo, ogni straniero
Ivi sta volontiero*

(Volpicella, 1880, p. 89).

1. Introduction

Artists, novelists and philosophers of the Renaissance have repeatedly sung the praises of Napoli Gentile in regard to its amiability for foreigners. While poet Giambattista del Tufo's lines depict foreigners' fascination with the city of Naples, writers eulogized foreigners' industriousness¹. In Aragonese-Habsburg times Naples hosted many foreigners such as the Florentines, the Genoese, the Spaniards, the Lombards, the Venetians, and the Greeks, all of whom established their own churches, neighbourhoods bearing their names, and poorhouses that benefited from their charitable spirit. Whether the citizens of these merchant nations settled on a permanent basis or established second residences in Naples, they all sought access to the lucrative trade. As the quotation indicates, Turks, Germans, Indians, and Italians all found commercial profit in southern Italy.

In their treatise on southern Italy, Mazza and Ucelli observed that «the infallible

* The paper was partially included in Dauverd, C. (2014), *Imperial Ambition in the Early Modern Mediterranean: Genoese Merchants and Spanish Crown*. New York: CUP. This research was funded by a Lynn and Maud White fellowship from UCLA's Center for Medieval and Renaissance Studies. I thank the generous funding from the IMPART (Multicultural Perspectives in Research & Teaching) grant at the University of Colorado, Boulder which has enabled me to present this paper at the 3rd International Conference on the Mediterranean World, Salerno (Italy) 9-12 September 2011.

¹ Neapolitan poet, Diomedea Carafa, lamented the lack of local entrepreneurial spirit but commended that of foreigners: "the sterility of the country ... is compensated by the industriousness of foreigners (Persico, 1974).

abundance of all kinds of goods, navigation, and commerce with the Venetians have enriched the people of the Kingdom. Its fertile land is a real warehouse where Genoese and Tuscans acquire their silk; Barbary gets almonds, oil, and meat; and Rome bread, wine, wheat, horses, lambs and sheep» (Mazza & Uccelli, 1598). Using the principle of trade diaspora, or commercial networks connected by family ties, these communities of foreign merchants linked the Italian south to their European and Mediterranean outposts throughout the premodern era.

Medieval Naples was a haven for commerce: it was a buzzing port-city with scores of foreign traders, markets, ports, and exotic items. Boccaccio described the city as «happy, peaceful, prosperous, and magnificent»². In Angevine and Aragonese times the Kingdom of Naples had become one of the anchors of western Mediterranean commerce. At the dawn of the fifteenth century the port of Naples was described by a Tuscan informant as «a harbour with two quays in which there are armed galleys at any given time, boats and wood in quantity overlooked by the marvellous Castelnuovo ... merchants that come and go are continuously greeted with sounds of trumpets and boisterous music, which is a spectacle to whoever arrives» (Kristeller, 1956, pp. 407-8). Beginning in the mid-fifteenth century, most Italian merchants from the municipal areas turned from trade with the Levant to the western Mediterranean, with the Italian south as one of their anchors³. The magnificent tavola Strozzi below illustrates the prominence of the harbor in Naples.

Fig. 1. *Tavola Strozzi, La città di Napoli al tempo del trionfo navale di Ferrante d'Aragona* (1464). Courtesy of the Museo Nazionale di Capodimonte, Naples



Studies of merchant life in early modern southern Italy are largely absent from the historical literature, but this subject merits attention because it reveals a new episode in the history of commercial relations between continental Europe and the

² The great Tuscan writer had come to Naples as a young merchant and a few stories of the Decameron were set in the city of Naples.

³ The Genoese from Chios brought spices, cotton, alum, while their two main export commodities to the east were grain and silk from Sicily and Apulia. Slaves (on behalf of Catalans) and timber were also a valuable income of the Genoese portfolio. Other items the Genoese traded were oil, grain, and salt. See ASG, AS 2647: Consoli Due Sicilie, Palermo (1506-1581) and ASN, Sommaria, Banchieri Antichi.

western Mediterranean. Because of Spanish political domination and foreign merchants' economic ascendancy, the historical literature has treated southern Italy as a peripheral and colonial area in premodern times⁴.

By examining Genoese bankers' records and Neapolitan guild registers, I have compiled a coherent account of the role of the region in the premodern economy. The emerging story portrays the *Mezzogiorno* as neither peripheral nor colonial, but as an influential participant in the precapitalist economy⁵. For instance, my examination of silk guilds' inventories shows that about half of the population of southern Italy was living off the silk trade during this period⁶. Other items such as grain, nuts, salt and oil were of equal exportable importance. Hence the kingdom acquired a crucial role in the European protoindustrial economy, whether under the auspices of colonial foreign merchants or hegemonic local aristocrats.

This paper has two purposes: first, to restore the status of the Kingdom of Naples as a vibrant commercial player in that it interacted with both northern Italy and the rest of Europe, thereby disproving the perception of a feudal, backward, and inanimate south⁷; and second, that its economy did not depend on foreign merchants because its internal markets had a vitality of their own⁸. Not only was south-

⁴ World historian Immanuel Wallerstein portrays southern Italy as peripheral to the world system economy and Giuseppe Galasso paints the region on the periphery of western commercial empires (Wallerstein, 1976). *The Modern World-System: Capitalist, Agriculture, and the Origins of the European World-Economy in the Sixteenth Century* (New York: Academic Press, 1976). Galasso argues that Calabria is the prototype of a "missed take off" and Apulia as overwhelmed by "provincialism." (Galasso, 1994, pp. 387-393). He bases these statements on a comparison with the developing industrialism in England and the Netherlands, of which Naples never took part.

⁵ The economy was still pre-capitalist or proto-industrial as it depended on family structures, network connections, and state control. An edited volume by Paola Lanaro (Lanaro, 2006) has shown the importance of the economic development of Italian cities and their proto-industrial districts. Focusing on cities in the periphery of Venice, the authors call for a reconsideration of the economic history of Venice and the Veneto in pre-modern times, focusing on their successful attempt to adjust to the changing European economy.

⁶ Southern Italians lived off the silk, either as a worker, merchants, masters, or dependents (children or wives of guild members) during the early modern era. See ASN, *Arte della Seta, Libri di Matricole*, Vol. I-XII. According to silk guild members, it is estimated that in 1582 about 100,000 people "lived on the silk" in Naples, hence half of the population "Quello che consiste il Tribunale dell'Arte della Seta" (AGSim, *Visitas de Italia, Legajo 25, Libro III folio 316t, f. 1*). In 1624 the same guild members counted about 300,000 people who "lived around the silk" in the kingdom including the dependents (ASN, *Regia Camera della Sommaria, Processi, Pandetta Comune, Fascicolo 592*). In 1694 about 60,000 people worked on silk making, thus one quarter of the population of Naples (ASN, *Regia Camera della Sommaria, Consultationum, vol. XC, folio 175, Consulta of October 16, 1694*).

⁷ Most studies on the Italian communes have concentrated on Tuscany and the Veneto, seen as the quintessential civic communities of the late Middle-Ages. Until recently, historians have contrasted the civic conscience of the northern communes with the lack of civic concern of the south (mainly agrarian and feudal). See Eckstein & Terpstra, 2009.

⁸ The most active debate about 'colonial economies' in the medieval Mediterranean addressed the place of the Italian south in the systems of exchanges linking the Italian islands and mainland southern Italy to the big cities of northern Italy and Catalonia. David Abulafia argues that the importation of southern Italian products had a highly stimulating effect on the northern Italian economy See Abulafia, 2002. He concludes that during the Middle Ages, there were 'two Italies' because a complemen-

ern Italy a full participant in the precapitalist economy, but it also benefited both foreign merchants and local producers. By bringing into play the Genoese interest in the silk industry, the strong commercial linkages between southern Italy and the European continent are made clear.

The Kingdom of Naples bloomed into a Genoese emporium for two centuries. The Genoese empire was a sea empire whose mercantile and maritime vocation connected southern Italy to the European continent in various ways. Italy was the dynastic, religious, historical, and geographical setting of the convergence of continental Europe and the Mediterranean Sea. Usually viewed as the fringe of the empire, southern Italy was actually an important node of the Spanish imperial system and held an active role in the Genoese trade diaspora in which it was integrated. The Genoese sea and land empire exploited its mercantile networks in London, Bruges, Seville, Lyon and elsewhere to establish its connections to the rest of Europe.

Since empires of the sea are mainly interested in exchange and in establishing trading monopolies, the region became a vital locus of interaction for the Genoese commercial empire⁹. The Genoese commercial praxis in the silk industry highlights its financial versatility, ability to link various mercantile nodes, and capacity to work on both land and sea. The relationship with silk in southern Italy underscores the Genoese empire's role in the two themes of production (surpassing the rest of the Italian peninsula) and interaction (establishing a complementary relationship with continental Europe).

The Genoese merchant nation made these connections by making different "career choices" and following the political developments of the Spanish Crown. Each of the three eras under review corresponded to an area of concentration that affected the Genoese merchants' relation with the silk industry. In the 1470s they started as artisans, switched to merchants by the dawn of the following century, and finally became bankers in the mid-sixteenth century. They deliberately moved from one sector to the next in order to increase both production and sales, resulting in ties to European markets that craved the kingdom's silk.

The first section of this discussion explores the Genoese as artisans, starting in the 1470s. Their success first stemmed from their capacity to work in concert with other trading nations, then Aragonese monarchs granted them royal dispensations

tary relationship between the two parts developed. To say that 'two Italies' existed does not necessarily mean that northern Italy naturally dominated its southern counterpart (Abulafia, 1977). From the work of Stephan Epstein, three distinct approaches emerge to define the economic relationship between the different economies of northern and southern Italy. The first approach emphasizes the dependence of Sicily on foreign merchants, proposing a 'colonial' relationship. The second approach emphasizes the continued vitality of the internal markets within the islands, downplaying the significance of foreign trade. The last approach seeks to avoid positive or negative value judgments about the island economy, insisting instead that foreign demand for the island products had a highly stimulating effect on the north Italian economy. See Abulafia, 1992.

⁹ Annalists who seek to approach history in its totality have recently pondered about the functioning of merchant networks in the early modern period, as well as their relationship with the economic structures and political institutions of the time. See Molho & Ramada Curto, 2003. For an example of Jewish trade diaspora and their commercial network in and beyond Italy see Trivellato, 2009.

in order to «enliven the silk industry»¹⁰. The second section covers the period from 1515 to 1580 and analyzes the Genoese transformation from artisans-merchants to a domination of the guild system. The Genoese continued to work in tandem with other nations, notably Neapolitans and Florentines, but they were the main exporters of Neapolitan silk, which they shipped to their European commercial nodes. The necessity of exporting silk fueled production in the guilds while the Genoese dominated them. The third section progresses from 1580 to 1650, and presents the Genoese conversion from merchants to bankers of the Spanish Crown. The Genoese continued to act as merchants but added the activity of financiers of the Crown, enabling them to bargain for continuous commercial privileges but also to link the kingdom to the precapitalist economy. Their involvement in the silk industry became more entrenched as they exported both raw and finished silk.

2. The Genoese as Artisans: Privileges and Cosmopolitan Alliances. 1470-1500

This segment examines the Genoese ability to exploit their partnership with other merchants (foreign and locals, but all Italians) as well as the financial privileges granted by the Aragonese Crown in order to penetrate the kingdom's commerce. Although the Genoese usually gained from their dealings with their conational network¹¹, in the kingdom of Naples their ultimate triumph stemmed from an increasing degree of adaptability and capacity to work with other trading nations¹². The commercial impetus derived from the monarchs' bestowal of financial privileges granted them a way to pierce the southern Italian market and replace the traditional medieval commercial monopolies of the Catalans and Venetians, and to obtain a pivotal role in the silk industry as merchant-artisans.

The Aragonese commercial policies that aimed at increasing local textile production assisted the Genoese assimilation into the kingdom of Naples. The creation of the silk and wool guilds in the mid-1460s by King Alfonso I (r. 1442-1458) made these two products the pillars of Neapolitan economy for three centuries (del Treppo, 1972, 210). This was accomplished by introducing the finer sheep of Spain, which improved the common Neapolitan breed. His son Ferrante (r. 1458-94) subsequently altered Alfonso's initiatives by prohibiting the introduction of foreign wools. Silk was an item of conspicuous consumption. The court, nobility, and priests purchased silk not only for clothing, but also for altar decorations and household furnishings.

¹⁰ ASN, Ministero dell'Interno 242, Capitolazione delle Antiche Capelle di Arti e Mestieri, vol. 5198 n.34: Arte della Seta, Napoli, 4 November 1474, section 1.

¹¹ Trading nations have been defined as «controlling minorities» stressing that «any minority will have a tendency to stick together, for mutual aid and self-defense: when abroad, a Genoese merchant would back up his fellow-citizen» (Braudel, 1982, p. 165).

¹² Francesca Trivellato argues that the diasporic communities able to work in tandem with other merchants were the most successful. See Trivellato, 2007.

Worked in the kingdom's regions of Apulia and Calabria but also Sicily since the thirteenth century, silk was one of the most desired items, not only as a source of prestige by the local aristocracy but also as an export commodity for the many merchant nations¹³. The kingdom provided raw silk (exported to be worked up elsewhere) and spun silk thread (woven into textiles elsewhere). The factories supplied velvets and brocades interwoven with gold, for the preparation of which the Venetians gave instruction. (Summonte, 1603). The produced silk was mainly for exportation and not for local consumption. During Aragonese times Genoese, Florentine, Venetian, and Catalan merchants became involved in its exportation mainly in raw form.

Fig. 2. *Foreign merchants and their trade in Naples in the mid-fifteenth century* (from del Treppo, 1972, pp. 198-204).

Catalans:	cloth, wax, leather, wool, slaves, spices, sugar, rice
Genoese:	cloth, metals, leather, slaves, salt, spices
Florentines:	cloth, iron and metals, spices, sugar
French:	cloth, coral, metal, hats
Milanese:	armaments
Venetians:	sugar, metals, dyes, and spices

The figure 2 based on merchant records indicates that there was a great deal of foreign investment in cloth, spices, metal, and sugar: the one thing that has been overlooked by scholars until recently is the investment in silk. While records indicate the generic term “cloth” most of this trade referred to silk. Why have scholars overlooked the importance of the silk industry, even if raw, in the Kingdom of Naples? The answer that research has concentrated on centers like Bologna, Venice, or Lucca, which had prosperous manufacturing industries, is unsatisfying. One possible reason stems from the possibility that the south had been a victim of the north- south dialectic, a colony of the north in the historiography and hence not a productive center. I propose that the reason lies in the fact that silk production was in the hands of a foreign market, destined for exportation, and thus not viewed as a significant source of local production and promoter of the economy. Only very recently have scholars appraised records from the silk guilds¹⁴. The Genoese regis-

¹³ Silk manufacture, originally centered in the east Mediterranean, had arrived in southern Italy by the eleventh century, as even the bishop of Reggio di Calabria carefully listed his mulberry bushes for silk-worms. Skinner considers that the product was probably exchanged for foodstuffs by Calabrian monks. Apart from magnificent items such as the coronation robe of King Roger II. It is clear that members of the aristocracy also wore silk clothing as sign of their social status. See Skinner, 2004.

¹⁴ Beginning of the twentieth century a number of southern Italian historians have devoted time to the study of trade in the Kingdom of Naples such as Giuseppe Coniglio (*Il Regno di Napoli*) and

ters indicate that their prominence was salient in a thriving local industry.

The Genoese established a close rapport with the silk industry because they benefited from the Aragonese monarchs' system of commercial privileges toward foreign merchants. The usage of fiscal privileges was feudal in substance, yet the economic implications were clearly modern in that it was production centered¹⁵. In the context of the Aragonese privileges were meant to stimulate economic production and local markets, encourage business partnerships, allow social mobility, and reduce imports. The graph suggests that the Genoese and other foreign merchants were already trading local commodities, but how did they get entrenched in the silk industry? They were already connected to exports but how did they get to this level of production? A very capable ruler, Ferrante invigorated the economy of the south by adopting measures that attracted foreign capital (Munck & Winter, 2012, p. 17)¹⁶.

In 1469, for example, he drafted an edict designed to increase the population of the city of Naples by encouraging the immigration of skilled foreign merchants¹⁷. Hence in this context privileges were used to attract skilled people. As a result, the Genoese joined the silk industry, the first transnational commercial enterprise in the kingdom to receive fiscal privileges. The first commercial corporation that benefited from Ferrante's royal privileges was an all-Italian affair comprised of Florentines, Genoese, Neapolitans, and Venetians. Ferrante's 1474 statutes to the Coppola-Cavensi-Di Nerone company specified: «The enterprise was designed to enoble and embellish the arts of the city of Naples»¹⁸.

Neapolitan merchants Luisa and Francesco Coppola created a commercial partnership with the Florentine merchant Francesco di Nerone and the Genoese silk weaver Pietro Cavensi. The company's commercial representative in the city of Naples was Venetian silk master Marino di Cataponte while the Florentine Hieronimo de Giutiante served as the go-between in Florence¹⁹. On 2 May 1465, Di Cataponte

Francesco Caracciolo (*Il Regno di Napoli*) but industry has always tended to be overlooked until recently. For a recent counterbalance see Ragosa, 2009. Because southern Italy was such a dominant center of silk production during the pre-modern era, the excellent study of Luca Molà (Molà, 2000) on Venice establishes links with the Kingdom of Naples.

¹⁵ The acquisition of political authority and dynastic property was a modern phenomenon. For an interesting discussion of the relationship between the French monarchy and the maintenance of the traditional elite's social position (Romaniello & Lipp, 2001).

¹⁶ Access to guilds, tax exemptions, and grant privileges functioned as typical instruments to attract "skilled migrant communities" in early modern cities.

¹⁷ «Nos tantem attendentes maiorem fieri frequentiam hominum exterarum nationum in hanc nostram civitatem Neapolitanam, quae caput nostril Regni est, ad domicilium contrahendum, eamque magis inde repleti libreris hominibus, ac fieri populosam turbis diversorum hominum, suas provincias et civitates relinguentium» (del Treppo, 1989, p. 226).

¹⁸ ASN, Ministero dell'Interno 242, Capitolazione delle Antiche Capelle di Arti e Mestieri, vol. 5198 n. 34: Arte della Seta, Napoli, 4 November 1474, section 1. The Genoese artisan name was sometimes spelled Cavensi and at other Cavursio. For the sake of consistency, I have kept the spelling Cavensi.

¹⁹ ASN, Ministero dell'Interno 242, Capitolazione delle Antiche Capelle di Arti e Mestieri, vol. 5198 n. 34: Arte della Seta, Napoli, October 5, 1477. In 1531, the Genoese Pietro de Cavensi, the Florentines di Nerone, and Di Giutiante, and the Venetian Di Cataponte were still registered as master in the art of silk making in the guild of the same name. These plus eight other Genoese craftsmen

became the first master weaver to obtain privileges for the making of silk cloth and production of velvets, satins, and damasks (Mola, 2000, p. 311). His activities were varied since he was also involved in the exportation of alum (Feniello, 2005, p. 207). Francesco Coppola was an important shipowner who traded regularly with various countries around the Mediterranean and cities of the north of Italy, and possessed strong commercial links both in Italy and in the Levant²⁰.

As for the Genoese Cavensi, he was a silk master who benefited from close connections with his compatriots in Naples. Coppola, Cavensi and Di Nerone linked the kingdom to long-distance networks across the Mediterranean. Their access to commercial nodes allowed them to reconvert capital into the “arts” of Naples. Trade and art were thus initially united for the economic prosperity of the region. Coupled with privileges, the commercial vision of the three Italians increased production, extended their commercial reach, and invigorated the local economy, which explains the admiration for the industriousness of foreigners mentioned in the introduction. The transnational state-sponsored manufacturing enterprise Di Nerone-Cavensi-Coppola thrived since it was endowed, in the usual way, with commercial and judicial privileges. Besides free access to all segments of the silk and gold business, the company benefited from countless other privileges such as enticing salaries, waived customs rights, and tax-free import-exports²¹.

Italian merchants and local artisans increased their mutual benefits and established linkages with the countryside. The citizens of Reggio, for instance, traded silk freely within and outside of the region and were exempt from customs fees in the cities of Gaeta, and the Calabria and Sicily regions (Coniglio, 1951, pp. 117-

were registered under the consulate of Pietro de Stephano, Jo Baptista Agnario, and Stephano Mayo-lo. See ASN, Mercanti registrati al Consolato del' Arte della Seta: Libro delle Matricole vol. 1. Microfilm vol. 1-12.

²⁰ He eventually became a feudal landowner, and acquired the title of Count in Sarno (Caracciolo, 1966, I, 79). Coppola's engagement in the kingdom was not merely commercial and along with other barons he defied Aragonese rule. He was part of the first Baron Conspiracy (1460-64) which supported the French Angevine House. By examining the king's involvement in the local guild manufactures, we will see that he had granted fiscal privileges to Coppola's silk company following the baron's rebellion of 1460-64. What can we deduce from this? Perhaps the king was “magnanimous” like his father Alfonso or, more likely, he sought to appease the merchant by focusing his attention on a commercial enterprise rather than on pursuing the feud. After the second Baron Conspiracy (1485-86), Ferrante lost patience and had Coppola killed on his wedding day.

²¹ ASN, Ministero dell'Interno 242, Capitolazione delle Antiche Capelle di Arti e Mestieri, vol. 5198, n. 34: Arte della Seta, Napoli, 4 November 1474, section 1. It included silk masters who belonged to the city's guilds and received from the king a salary of «200 ducats for provisions, 100 other ducats to the gold and silk guild masters» (section 2).

The king also waived the customs rights on all the participants in the joint venture, which was «free and exempt of payment of customs, gabelle, and other rights that are usually paid for gold and silk, regardless of whether they originated from the Province of Calabria or whether they were exported. These rights also applied to all products involved in silk production, such as dyeing products, color, alum, machinery, looms, and grain (section 3). «The Di Nerone Company shall export by land or by sea any quantity of gold, silk, and colors involved in the production of said art. It shall also be granted the privilege to export and import freely from and to the city and kingdom of Naples» (section 4).

120). Becoming leaders in the silk industry mustered local and foreign talents, enabled merchants to deploy their commercial skills connecting Naples to their other locations, and provided the king with regulating rights while furthering the kingdom's economy.

The Genoese prospered because merchants and artisans received civil protection: the company's privileges included diplomatic rights of immunity²². Its foreign merchants and craftsmen also received rights similar to Neapolitan citizens. Likewise, the company was made dependent on the Camera della Sommara, a tribunal made up of Aragonese, and later Castilian delegates. This ensured the king's control over proceedings involving guild members prosecuted on civil or penal grounds²³. Similarly, the king made the Di Nerone's members his vassals with all the rights and responsibilities that this act entailed²⁴. For the Genoese Pietro Cavensi, being a king's vassal meant that his merchandise was exempt from excessive taxation and received the protection of the Aragonese tribunals. Commercial privileges became a model for future business enterprises because numerous fiscal and judicial dispensations invigorated foreign merchants' trade in the kingdom²⁵.

The graph below (Figure 3), pieced together based on bankers' records, reveals that Catalans were the most numerous foreign merchants in the mid-fifteenth century, followed by the Genoese, then by an equal number of Florentines and French. These numbers indicate that the market was mainly in the hands of foreign merchants but that the Italians were second to the Catalans, the nation of the Aragonese

²² «His Majesty guarantees that during the duration of the said art's work, the guild members should not be detained inside and outside the kingdom pro quavis causa» (ASN, Ministero dell'Interno 242, Capitolazione delle Antiche Capelle di Arti e Mestieri, vol. 5198, n. 34: Arte della Seta, Napoli, 4 November 1474, section 5.) In 1478, a decree stated that every man employed in the silk industry, whether silk weaver, master artisan, or simple journeyman enrolled in the guild registers was immune from prosecution for civil or criminal offenses perpetrated outside of the kingdom. See Molà, 2000, p. 31.

²³ «The ministers of the said art of the Di Nerone Co. will not undergo whether for civil or for penal cause a tribunal other than the Camera della Sommara» (ASN, Ministero dell'Interno 242, Capitolazione delle Antiche Capelle di Arti e Mestieri, vol. 5198, n. 34: Arte della Seta, Napoli, 4 November 1474, section 7).

²⁴ «His Majesty requires Francesco & Co. to be part of his vassals» (ASN, Ministero dell'Interno 242, Capitolazione delle Antiche Capelle di Arti e Mestieri, vol. 5198, n. 34: Arte della Seta, Napoli, 4 November 1474, section 8). The Genoese Petro di Cavursio, master of the silk guild in the year 1475 exhibited similar privileges. First, he was given the right to bring into the kingdom twelve men to assist him. Second they could come and go freely with their merchandise without being taxed. Third, they had the freedom to export the silk «in all the parts of the world», and were free from gabelles and customs. Fourth, they had the right to dye or have the silk died. Fifth, they would be treated in the same way as Neapolitans, and be taken to no magistrate or judge other than the Camera della Sommara. See ASN, Ministero dell'Interno 242, Capitolazione delle Antiche Capelle di Arti e Mestieri, vol. 5198, n. 34: Arte della Seta, Napoli, Castel Nuovo, 1475.

²⁵ In 1523, the *università dell'arte della seta* was granted the right to erect a church. The Duke of Maddaloni bought the church on behalf of the guild which was called the Church of San Filippo e Giacomo. See D'Aloe, 1883.

kings. In the mid-fifteenth century more merchants settled in the Kingdom of Naples in order to take advantage of the privileges granted by the Aragonese Crown. These were mainly Catalans, Genoese, and Florentines. The sixteenth century would see an increase in the number of Genoese involved in commerce in the kingdom, as I will show below.

Fig. 3. *Relation between numbers and financial involvement of foreign merchants in the Kingdom of Naples c. 1470.*

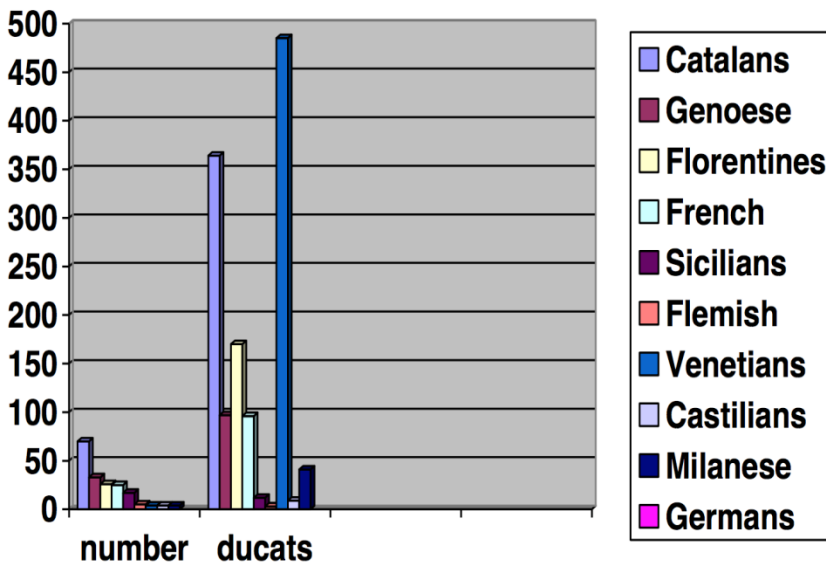

If we now look at the ducats, or financial investment in the mid-fifteenth century, the Venetians led by far, followed by the Catalans, then the Florentines in distant third. In fourth position the Genoese and French were tied. These numbers imply that even though the number of Catalans, Genoese and Florentines exceeded that of Venetians, it was the lagoon nation that “owned” the kingdom by exporting its raw product to the Veneto and European fairs. The Venetians sold most of the kingdom’s products, including the silk. This is important because it means that beginning in the Middle Ages the kingdom’s commerce was in the hands of foreigners. It also means that there was an industry of raw products exported elsewhere by foreign actors. Ferrante’s indulgent policies regarding the Italian merchants slowly reversed the balance of trade in the kingdom, with more Florentines and Genoese involved in the silk industry toward the last quarter of the fifteenth century.

The silk industry was such a thriving sector that Ferrante encouraged both foreign merchants and wealthy aristocrats to contribute to it more actively. Having attracted skilled merchant-artisans, Ferrante resorted to drawing capital. In 1477 he called for the participation of Neapolitan barons, and shortly thereafter edicts or-

dered Florentines and Genoese to settle in the kingdom²⁶. In 1481 the king ratified the collaboration of foreign nations in the wool industry, allowing «Neapolitans, Catalans, Spanish, Genoese, Ragusans, Milanese, Bolognese, and Florentines to introduce to the city of Naples the art of cloth making, which has been useful and of great benefit to the city, its subjects, and the vassals of the kingdom»²⁷. The previous year the Turks had raided Otranto, taking half of the population captive. Since Apulia was one of the kingdom's major silk distributors, the Ottomans foray must have troubled both the king and traders²⁸.

In 1483 the need to attract private capital for the art of silk making called for «everyone, noble or merchant, citizen or foreigner who will pledge his money to the benefit of the said art» (Tescione, 1933, pp. 18-9). Ferrante's interest in the kingdom's commercial life reached its climax when he received the guild masters who sought to increase production of these textiles²⁹. In 1483 he opened up the dyeing industry to Florentines, Venetians and Genoese, whose cities had acquired a reputation in Europe in the fifteenth century, thereby allowing for new methods of coloration to be developed in the kingdom (Ferorelli, 1999). Genoese merchants quickly seized this opportunity and opened dyeing shops in Naples.

Ferrante was successful not only at ennobling the arts of the kingdom but also at increasing production. The expertise of the trade diaspora communities heightened sales: 80 percent of the silk purchased went through the fairs (Del Treppo, 1972, p. 213). During Ferrante's reign the number of fairs across the kingdom doubled to about 230 every year (Astarita, 2005, p. 78). The escalation in silk production was notable. In 1293 about 4,300 pounds of silk were produced per year, in 1466 it rose to 30,000 pounds, doubled in 1481 to 64,000 pounds, and reached 70,000 pounds in 1496 (Minieri-Riccio, 1863, p. 84)³⁰.

²⁶ In 1483, the Spanish envoy recorded that King Ferrante had sent an invitation to the Neapolitan barons in 1477 to participate in the silk manufacture. See AGSim, *Visitas de Italia*, fascicolo 25, folio 314t. To do so, Count Diomede Caraffa and Count Giancarlo Tramontano were made protectors of the Art of Silk making. Francesco Coppola, Count of Sarno was invited along with Neapolitan merchants to participate actively in this endeavor such as Di Nerone, Cavursio, Cataponte, Folliero, Vespolo, the Tuscans Vecchietti and Strozzi and the Genoese Spinola. All in all, there were 104 merchants of which eighty were Neapolitans, ten Genoese, six Florentines, and a handful of Venetians, Milanese, Catalan, Spanish, and Pisans. Also ASN, *Arrendamenti, Arrendamento della seta*, fascio 1647, *Summario de arrendamenti*.

²⁷ ASN, Ministero dell'Interno 242, *Capitolazione delle Antiche Capelle di Arti e Mestieri* vol. 5197, n 18: *Arte della Lana*, Letter from King Don Ferrando, Napoli, 13 January 1481.

²⁸ Following the Muslim attack on Otranto, the Genoese Doge called on its Genoese subjects scattered across the Mediterranean to assist King Ferrante. «1480 proposta fatta in consiglio di governo a Genova per aiutare il Re Ferdinando contro l'armata turca a Otranto» (ASG, 2774 A *Materie politiche* (negoziazioni e trattati con le potenze estere Oriente e Africa-Costantinopoli).

²⁹ See ASN, Ministero dell'Interno 242, *Capitolazione delle Antiche Capelle di arti e Mestieri* vol. 5198, n 33: *Arte degli Orefici et Argentieri*, Article n. 2, 3 August 1593 [1481].

³⁰ ASN, *Arrendamenti, Arrendamento della seta*, fascio 1647, *Summario de arrendamenti*.

3. *The Genoese conversion from artisans to merchants: guilds and production, 1515-1580.*

This section presents the conversion of the Genoese from artisans into guild masters and exporters of silk. Artisans were local residents, but foreigners monopolized the reselling portion of the trade. While they always dedicated themselves to reselling, the role of the Genoese as guild masters afforded them a crucial role in production. A close examination of the silk guild registers thus reveals that not only were they involved in the guild but also they nearly monopolized it. This section makes two claims: first, that there was an explicit relationship between the role of the Genoese in the guilds and that of exporters of Neapolitan silk, and second, that their role as guild masters pushed production to export the much sought-after silk. The gradual insinuation of the Genoese into Naples's guilds underscores their capacity to both work in tandem with other merchant-nations and connect the Italian south to their commercial nodes on the European continent.

In 1514 King Ferdinand III of Aragon, also called the Catholic Monarch (r. 1504 on the death of Isabella) welcomed the foreign work force and their skills: merchants and foreigners who manifested interest in participating in the local administration received dual citizenship (Romano, 1994). The Genoese who benefited from Ferrante's privileges were present in the guild system mainly as artisans. By becoming masters of the silk guild themselves, the Genoese made an important career shift concentrating on the training of artisans. They simultaneously maintained their role as merchants, shipping the silk to their European entrepôts. Their dual-focused occupation induced artisans to increase production since the real benefit was in the reselling. The Genoese knew the market and influenced it because their main outlet for the silk was Genoa.

The Genoese were the main exporters and consumers of "Neapolitan" silk. Silk was destined for exportation and not for local use. The greatest export of southern silk was Genoa, followed by important centers such as Rome, Milan, Lucca, and Ragusa. But Genoa itself did not produce enough raw and spun silk to meet the demand from its own weavers: most of that raw material had to be imported, and much of it came from the Mezzogiorno, through the agency of the Genoese merchants there. Silk was not woven locally but rather shipped to other economic centers such as Lucca, Genoa, and Bologna. The Kingdom figured in this schema more as a source of raw materials than as a producer of finished textiles. The real profit was in the weaving of fine textiles, and the Genoese were careful to keep this sector of production for themselves³¹.

The Genoese involvement in silk production and exportation was both commercial and cultural. The Genoese silk industry followed the Ligurian capital's fashion. In the early sixteenth century black became the dominant color produced, and

³¹ ASN, Consulte, Arrendamento della seta, Sommario de Arrendamenti, Vol. 1968, Concordia tra la Regia Corte, l'Arrendatore delle sete ed i Consoli dell'Arte della seta, 15 November 1580, ff. 158 -163.

Genoa was famous for its beautiful black velvets. Black was the color of the nobility, of church members, of men of law, and of funerals. The link between Genoa and Naples was therefore strong because the Genoese fancied the silk (Epstein, 1996, pp. 232, 276). Rosalba Ragosta notes that from 1570 to 1600 the Neapolitan silk manufacturing industry declined but the exportation of raw silk increased (Ragosta, 1999). The explanation lies in the fact that first the Genoese operation in the silk trade was only one part of their overall commercial operations as a nation³². Then, over the course of the sixteenth and part of the seventeenth centuries, the introduction of raw silk accounted for almost half of all Neapolitan imports to Genoa (Kirk, 2005, 86). For instance, in 1516 the Genoese exported to Genoa 45,000 pounds of silk, in 1521 about 50,000, and in 1537 around 90,000 pounds (Gioffré, 1962). From 1578 to 1778 the Genoese involvement in the silk guild continued to increase especially the period from 1607 to 1630 (Ragosta, 1999).

Naples's guild system enabled the Genoese to control silk production and sales. The Neapolitan guild system was an anomaly because the Genoese completely dominated it by holding the focal position of guild master. In contrast, on the European continent guilds made it very difficult for newcomers to enter their ranks in order to maintain privileges and status for themselves (Burr Litchfield, 2002, pp. 82-103). Across Europe the position of guild master, a privileged position overseeing the general population of artisan craftsmen, was generally held by local members of the merchant class. In this situation few guild members were foreigners, but in Naples the opposite was common (Jacoby, 1997)³³. Silk registers indicate that half of the guild masters were Neapolitan while the other half was foreign to the kingdom. The Genoese dominated the guild system by holding the two positions of guild master and guild merchant. In fact, in each silk guild half of the masters were Genoese as were half of the merchants.

This anomaly clearly resulted from the fact that the Aragonese and Spanish administration used foreigners' craftsmanship to their financial advantage. The Aragonese granted privileges permitting the Genoese to penetrate the local industry. The number of people accepted in the guild was dependent on the amount of taxes the Spanish state collected. The foreigners who could afford them paid the high taxes on corporations' matriculation fees. Guild masters held the secrets of the trade, but were also responsible for the production of the guild. Hence those who had a stake in the economy fueled production and paid taxes to the viceroial court³⁴. This sys-

³² Tommaso Campanella ironically described the situation: «no sooner any artisan had gathered hundred ducats, he invested into buying grain rather than pursuing the art [guild industry], this way he pretended to be noble without using his hands» (quoted in Firpo, 1945, p. 184). The Genoese were involved in silk, grain, olive oil, salt, alum, cheese, nuts, and myriads of other products of exportation.

³³ Ragosta, 1998.

³⁴ Luigi De Rosa argues that through the matriculation fee the Spanish viceroys transformed every craft into a guild as a means of income (De Rosa, 1991). The numerous restrictions imposed on the guild merchants and producers led to abundant litigation. ASN, Regia Camera della Sommaria n.20, Curia dell'arte della lana, Inventario n 512. Similarly, guild members were constantly tried for infringing on laws regarding cloth dyeing, debts to local merchants, or tax owed to the Spanish admin-

tem guaranteed the well-being of trading minorities while heightening production backed by the avid hand of the Spanish state.

Fig. 4. *Activity of Nations in the Neapolitan Silk Guild from 1515 to 1600.*

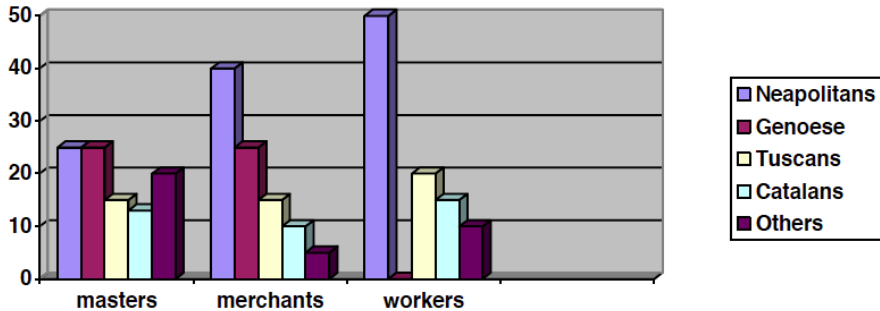

Source: ASN, Mercanti registrati al Consolato del' Arte della Seta: Libro delle Matricole, vols 1 to 6

The above graph (Figure 4) illustrates the Genoese monopoly on the silk guilds as both masters and merchants. The registers include three categories in the silk guilds: masters, merchants, and workers. The Genoese were conspicuous in the first two categories. Utilizing their talents as guild masters and/or silk traders, they left the actual craftsmanship to local artisans. The Neapolitans tended to production and local dissemination while Genoese merchants handled the distribution outside the kingdom. The inventories of merchants registered in the silk guild provide critical insight into the functioning and distribution of the nations involved in its production. Interestingly, a redistribution of the diasporic communities occurred.

First, Neapolitans composed the greatest number of merchants, which highlights the dynamism of internal markets. Second, the Genoese were no longer connected to craftsmanship, dedicating themselves entirely to mastership and sales. Third, Venetians were no longer included while the Tuscan nation was evenly distributed among the three categories. Finally the total number of Neapolitans involved indicates that they were by far the most important group, but in terms of positions of power the Genoese undoubtedly led. In Naples from 1515 to 1558, one of the guild masters was invariably a Genoese. In fact, the number of Genoese masters equaled that of Neapolitans³⁵.

The Genoese came to control production and distribution because of their involvement with European markets that demanded Neapolitan silk. From 1558 to 1570 they consolidated their merchant roles, working in concert with Neapolitans, Spanish, Catalans, French, Flemish, Germans, and traders from the rest of the Ital-

istration. See for instance ASN, Regia Camera della Sommaria n.20, Curia dell'arte della lana, Fascio 1 fascicolo 11: Atti per la creazione dei consoli della curia. Articoli addotti nella causa di Don Pedro de Toledo contro i consoli della curia. Quietanza (1546-1554).

³⁵ ASN, Mercanti registrati al Consolato del' Arte della Seta: Libro delle Matricole vol 1. Microfilm vol. 1-12.

ian peninsula such as Milanese, Florentines, Venetians, Romans, Lucchese and Messinese³⁶. As exportation grew, Genoese merchants emerged as the indispensable link between local production and European markets. This is indicative of the Genoese capacity to adapt to their new social environment but also of their commercial versatility. They were able to connect northern and southern markets while the Neapolitans were not. As a result, the dichotomy between production (dominated by Neapolitans) and exportation (dominated by foreigners) became so severe that in the 1600s Antonio Serra described the Kingdom of Naples' citizens as displaying little industriousness³⁷.

Figure 5. *National distribution of the Neapolitan silk guild from 1515 to 1600*

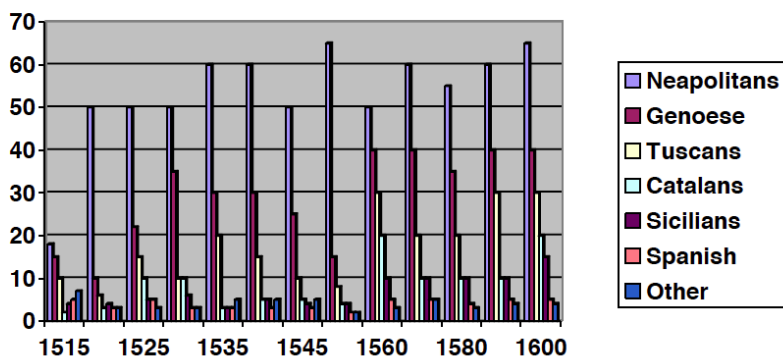

Source: ASN, Mercanti registrati al Consolato del' Arte della Seta: Libro delle Matricole, vol. 1.

Because major guilds gradually fell under the control of Genoese merchants, the guild system became a means for dominating the labor market³⁸. The above graph (Figure 5) emphasizes that from 1515 to 1600 the Neapolitan nation was the chief nation involved in silk production, followed immediately by the Genoese and then

³⁶ ASN, Mercanti registrati al Consolato del' Arte della Seta: Libro delle Matricole vol 1. Microfilm, vols. 2 and 3 (1573-1584), vol. 4 (1584-1592) and vol. 5 (1592-99).

³⁷ «Not only do Neapolitans not tend to commerce outside of Italy or any other region of the peninsula, but they are not even able to emulate the entrepreneurship of the other Italians in the kingdom» (Serra, 1613, p 105). This lack of entrepreneurship might have been due in part to the entrenched feudal system which produced land owners rather than traders. Those who engaged in trade, however, made wrong political alliances, as the rebellions of 1464 and 1528 exemplify. Following these upheavals, the local nobility lost both lives and estates.

³⁸ Recent scholarship on European economic history argues that due to innovation, technological change, and entrepreneurship early modern craft guilds formed the backbone of industrial production before the rise of the steam engine and created institutional environments conducive to technological and marketing innovations. See Epstein & Prak, 2008, especially Epstein, 2008 and Trivellato, 2008. For Venice see the quintessential study of Robert Davis (Davis, 1991). The city's shipyard hosted the greatest manufacturing complex in early modern Europe with about three thousand masters, apprentices, and laborers.

the Tuscans. Even though they were second to the Neapolitans, the Genoese truly steered the silk industry. At the end of the fifteenth century the masters of the craft lost their independence to merchant capital, enabling the Genoese to make a true impact on the guilds. Even though the guild structure remained intact, it served as a mere façade that allowed the merchant-entrepreneurs to hide the full extent of their power (Guenzi, Caselli & Massa, 1998). As a result, throughout the Italian peninsula merchants were labeled the real masters of the “trading game”. (Braudel, 1982, p. 301). The relationship between merchants and master craftsmen became conflicted: while artisans favored professional prestige, merchants worked according to the principle of competition. Neapolitans artisans sought to produce good quality pieces whereas Genoese merchants concentrated on production, therefore organizing production for export.

The collaboration between local and Genoese merchants through the guild transformed southern Italy into one of the European leaders in silk production in Habsburg times. In 1527 the Venetian ambassador Marco Foscarini estimated the production of silk in Florence at 33.900 kilos (74.580 pounds), when we know that at the beginning of the seventeenth century it was at 69.900 (153.000 pounds). Contrast this number with Naples where the government calculated 40.100 kilos (88.000 pounds) prior to 1578, after which it shot up to 104.300 kilos (228.000 pounds), surpassing Florence by far³⁹. Between 1607 and 1608 guild members recorded consumption of 202.500 kilos (444.400 pounds), which clearly put Naples at the top of European silk-cloth production in the early seventeenth century (Mola, 2000, pp. 18-19).

Recent data estimate that Calabria alone produced 181.800 kilos (or 398.200 pounds) of spun silk by the mid-sixteenth century, a number that doubled by the last quarter of the century (Caracciolo, 1966, p. 155). This number indicates the amount exported via the customs office, not of that produced, since we know that much of the silk was exported clandestinely (Ragosta, 2009, pp. 20; 40). In fact, recent estimates determined production in the regions of Terra di Lavoro, Capitanata, Contado di Molise, Bari, and Otranto to be about 722.000 pounds in 1588, while Calabria alone produced at least 900.000 pounds in 1615 (Galasso, 1992, pp. 172; 370). The Genoese afforded Naples a conspicuous position in European markets. Their ability to connect the kingdom to their commercial nodes created important outlets for Neapolitan silk.

³⁹ This number is explained by the fact that most of the silk did not enter local production but was shipped to be manufactured elsewhere in the peninsula or on the European continent.

4. The Genoese conversion from merchants to financiers: Naples connects to Europe, 1580-1650

This last section examines the final conversion of the Genoese from merchants to financiers. The Habsburg political and commercial centralization of the royal domains benefited the Genoese. Operating as financiers of the Crown, they were able to bypass laws in the kingdom and prolong their use of the south as one of its emporia, thereby reinforcing the economic relationship with their European entrepôts. Inevitably emerging «on top of the trading game», the Genoese exported different types of silk from the kingdom, thus enriching European markets, southern Italy, and their own commercial network.

There was a direct correlation between the Genoese predominance over the silk trade and their services to the Spanish Crown. While at the dawn of the sixteenth century competition over southern Italy's market existed, with the Habsburg ascent Florentines and Genoese, two banking nations, supplanted both the hegemony of Venetian trade and the preeminence of Catalans in the kingdom's commercial pursuits. This drastic change is understandable if the dependency of the Spanish Crown on its financiers is recognized. Neither the Catalans nor the Venetians reconverted from commerce into banking. Both Genoese and Florentines provided massive loans to the Spanish Crown, which neither Venetians nor Catalans were able to do. Banking and commerce thus became inexorably linked. The fate of the kingdom lay with the nation that could most invest the most in the interests of the Spanish crown.

The transition from artisan-merchants to merchant-financiers followed the Spanish Crown's dependence on reliable financiers. This conversion can be best understood by assessing the events of those years. The Crown changed in 1556, making the Genoese the bankers of the Spanish empire. This meant that the Genoese reconverted from merchant artisans to merchant bankers. The shift from artisans who concentrated on quality and production to merchant-bankers who concentrated on production for exportation, sales, and profit was in tune with their new banking vocation. The period 1570-1600 was thus one of steep economic growth for the Genoese. After 1571, another crucial year for Mediterranean relations, the Genoese became the alter ego of the Spanish Crown. In this century, the Genoese focus on finances, exports, and banking, with services rendered to the Spanish Crown became more concrete⁴⁰. Their heavy involvement in finances, both in Naples and Habsburg Europe, coincided with an increasing interest in silk guilds. Along with grain, the Genoese investment in silk production and export formed the basis of their economic stake in the kingdom.

⁴⁰ In his study of the Genoese capital Quentin van Dosselaere (Van Dosselaere, 2009, p. 207) claims that during the fifteenth century with the loss of control of trading routes, commerce suffered. However, the tighter core of elite families was well positioned for the 16th century's first wave of financial capitalism because raising funds and accessing liquidity were dependent on dense banking connections Genoa enters European politics more than any Italian city-states.

By utilizing their mesh of ties with foreign merchants, local producers, and Spanish kings, Genoese merchants succeeded in connecting the kingdom to the greater European economy⁴¹. While using their northern European network, notably Flanders, to export cloth from Naples to their international markets (Marino, 1992), Naples served as a trading outpost from where foreign entrepreneurs could ship their merchandise to their European entrepôts of Netherlands, England, Spain, and Genoa. The region generated resources that circulated in the European fairs, thereby enriching both Genoese and European markets. Southern Italy thus became one of the Renaissance emporia of the Genoese. In the mid-sixteenth century the merchandise exported from the kingdom, such as oil, grain, silk, wool, and nuts, was valued at three million scudi per year, whereas imports totaled only 600.000 scudi (Coniglio, 1951, p. 145). The Genoese and other Italian merchants who served the Crown performed a large part of the distribution.

In 1580 local and global developments facilitated Genoese organizational trade aspect. Although production was still centered in Calabria, the guilds, tribunals (which granted licenses to export), foreign banks and merchants (mainly Genoese), and the viceroial court made Naples an international center of commerce. Those engaged in the guilds were to be registered in the capital city. In 1580 Naples became the center of silk exportation for southern Italy. Genoese merchants provided financial stability in the realms: most of these merchants traded in silk, grain, and oil, and served as tax farmers for the Spanish authorities. In that year the Crowns of Portugal and Castile were united. This politics of centralization in Castile led to a politics of commercial centralization in southern Italy. Hence these structural policies facilitated merchants' exportation of silk. First, Naples became a Genoese entrepôt; second, the Crown was able to keep an eye on taxpayers involved in the guilds; and third, silk had to be shipped from Naples.

From 1580 on, the Kingdom of Naples exported both raw silk and finished silk products. In that year a *Concordia* among silk tax farmers, silk guild members, and the Spanish customs house agreed to increase twofold the exportation rate on raw silk⁴². One would assume that this would bring the prosperous silk exportation to an end because silk exporters could not afford to lose such money in their transactions, which were now based on the value and not the weight of the silk. Instead, the *Concordia* first produced an increase in the manufacturing of finished cloth made out of silk. Naples now manufactured both silk threads and woven textiles. Second, the merchants sold their silk locally rather than exporting it. This meant that local markets had commercial vitality. Third, the benefits of this initiative re-

⁴¹ Domenico Sella (Sella, 2009) has argued that large cities in the hinterland of Italy (away from the typical centers of Florence, Venice, and Milan) were becoming increasingly the centers of industries such as wool, iron, and papermaking because they were cheaper in a myriad of ways. Firstly, the countryside was not subject to the rigid guild system, and secondly the hefty tax of large cities was inexistent.

⁴² ASN, Consulte, Arrendamento della seta, Sommario de Arrendamenti, vol. 1968, "Concordia tra la Regia Corte, l'Arrendatore delle sete ed i Consoli dell'Arte della seta," 15 November 1580, ff. 158-163.

sulted in the monopoly of foreign merchants who were able to negotiate the tax on raw silk with the Spanish authorities. Hence they exported both finished and non-finished cloth, thereby pursuing export of raw silk to Genoa and that of finished silk products to the rest of Europe. Foreign merchants used locally woven silk (no longer the raw silk) and exported it to the cities of Genoa and Rome, but also to Lucca and Milan, changing the productive aspect of the city of Naples's *tessitura* (Delumeu, 1979, pp. 26-27).

From 1580 on silk was sent to various cities on the European continent, which indicates that northern markets depended on southern production and Genoese suppliers⁴³. The *tessitura* of Naples were supplied with raw wool and silk from Apulia, Abruzzo, and Calabria, creating a real presence of southern Italy in the international market of silk manufacture (Grimaldi, 1780). Silk became the chief resource along with other exported products such as saffron and wool. Productive capacity in Naples reached 3200 bales of raw silk per year and the exportation of this material surpassed this number by at least 200 bales because of clandestine exports. At least one million bales were manufactured outside of Naples, especially in Catanzaro, which became the principal center of manufacture closely followed by the capital. We know that about 90 percent of the silk that was produced in Sicily was destined for Genoese merchants⁴⁴. Genoese merchants depended on local production, which itself relied on export by merchants. Cities such as Reggio, Paola, and Tropea asked for silk manufacture facilities to be opened: this was granted in 1611 and 1613. Tropea claimed that production costs would fall if foreign merchants did not import the cloth and export the raw silk.

The map below (figure 6) illustrates the spread of silk markets across the European continent, which made the *Mezzogiorno* a major link among consumers of fine cloth. Thanks to the *Concordia* Naples eventually became an exporter of finished silk commodities, called "new cloth" or "light cloth" and embroidered with silver and gold, to foreign markets such as Flanders, Holland, England, Germany, Poland, and Spain. In the later sixteenth century the silk exports from Naples came from both finished cloth and raw and spun silk to be woven into fabrics. About 80 percent of the silk trade was carried on through fairs in Italy and Europe, such as Besançon, Piacenza, Provins, Troyes, and Medina del Campo⁴⁵.

⁴³ For instance, Giulio Ravaschiero bought in Stilo 142 pounds of silk (ASRC, G. Vitale, f. 23, 5 March 1563) while Pietro Francesco Ravaschiero acquired 480 tomoli of grain (ASN, Sommaria, Relevii, p. 352, ff 464).

⁴⁴ ASG, A.S. 2634 (1529-1804: Gaeta-Messina-Palermo) Letter from Consul Stefano de Franchi to Dux of Genova, 3 December 1565.

⁴⁵ Fernand Braudel (1982, p. 91) refers to the Genoese *cambiatori* who met four times per year at the Fairs of Piacenza.

Fig. 6. *Exportation of Neapolitan silk from 1580 on.*



Foreign merchants like the Florentines and Genoese conquered new markets by distributing new Neapolitan silk wares⁴⁶. It was a win-win situation for the merchants for whom the city of Naples had become a silk haven. Similarly, southern Italy became a European leader of fine textiles.

Throughout the sixteenth century silk production steadily increased: 524.000 pounds were produced in 1550, 560.000 pounds in 1580, and a grand total of 816.000 pounds in 1586 (Caracciolo, 1966, pp. 154-6). In the seventeenth century these numbers escalated, indicating avid foreign markets for Neapolitan silk. The customs house of Naples registered about 635.000 pounds of silk in 1607 «for the use of the guild»⁴⁷. These numbers suggest that both production and profit increased, and also signify that Naples was commercially linked to the rest of Europe via the Genoese, who made handsome profits. Writers of the time state that the Spanish kings (Habsburg) were able to acquire 2.500.000 ducats each year from the Kingdom of Naples. Of this, the Kingdom of Naples's tax on exported raw silk provided 250.000 ducats per year to the Spanish state⁴⁸.

⁴⁶ For a contemporary study on Florentine silk taxation see *Provisione*.

⁴⁷ ASN, *Arte della Seta*, II numerazione, b. 19, fascicolo 14, "Conto di sete sane e filate che si introducono in Napoli per uso dell'arte per fare drappi dal 31 luglio 1607 al 9 luglio 1608."

⁴⁸ In the mid-sixteenth century, southern Italy produced a total of 1.200.000 tomoli of grain (forty-eight million kilos or more than 105 million pounds) (Mazza & Uccelli, 1598, p. 123).

5. Conclusions

A scholar of the Mediterranean has recently proposed that the region can be better understood if we examined history through its ecological habitat, offering the systemic approach of the fig leaf⁴⁹. Fig leaves generally hide something of greater importance behind them. Similarly, southern Italy hid behind the greater silk manufacturing cities of Venice, Lucca, and Bologna. In exploring the Genoese conversion from artisans to merchants and finally to financiers, the fruit behind the leaf suddenly emerges.

The Genoese involvement in the silk guild, whether at the manufacturing or distribution level, had a deep impact on local and international markets. The internationalization of guilds allowed large-scale production and distribution. The Genoese pressed the Neapolitan guilds to adjust to the ever-increasing market. As a result of Genoese collaboration with local merchants and artisans, the Kingdom placed among the leading European metropolises in commodity exports in early modern times.

The Genoese involvement in silk distribution had both local and continental implications. At the height of the early modern age, for instance, southern Italy was the only one of all the Spanish domains in Europe that produced a continuous surplus (Braudel, 1972, p. 503). The mid-sixteenth century marked a watershed in the history of the Kingdom's industry. Genoese artisans became financiers of the Crown as their mercantile investments buoyed the ever-increasing financial needs of the Habsburg empire. At the same time, the Kingdom of Naples emerged as a vital component of the precapitalist economy. Naples became one of the Genoese emporia and was an integral part of their commercial empire. As maritime historians have recently suggested, "In the study of the socio-economic of the [Mediterranean] sea, 'states' and 'empires' remain ever present in the background" (Fusaro, 2010). Thanks to the long-distance trade networks of diasporic nations, the Aragonese-Spanish Crown's encouraging cosmopolitan environment, and the bestowing of commercial privileges and economic competition southern Italy became an important segment of the greater premodern European economy.

References

- Abulafia, D. (1977). *The Two Italies: Economic relations between the Norman kingdom of Sicily and the northern Communes*. Cambridge: Cambridge University Press.
- Abulafia, D. (1992). *An Island for Itself: Economic development and social change in late medieval Sicily*. Cambridge: Cambridge University Press.
- Abulafia, D. (2002), Introduction: Seven Types of Ambiguity, c.1100-1500. In Abulafia, D. & N. Berend (Eds.), *Medieval Frontiers: Concepts and Practices* (pp. 1-35). Burlington, VT: Ashgate.

⁴⁹ Peregrine Horden, conference on "Can we Talk Mediterranean?" University of Colorado, Boulder 6-7 April 2012.

- Astarita, T. (2005). *Between Salt Water and Holy Water: A History of Southern Italy*. New York: W. W. Norton.
- Braudel, F. (1972). *The Mediterranean and the Mediterranean World in the Age of Philip II* (trans. Siân Reynolds). New York: Harper and Row.
- Braudel, F. (1982). *The Wheels of Commerce: Civilization and Capitalism 15-18 Century*. New York: Harper and Row.
- Burr Litchfield, R. (2002). The social world: conflict, collision, and the city. In J.A. Marino (Ed.), *Early Modern Italy*. Oxford: Oxford University Press.
- Caracciolo, F. (1966). *Il Regno di Napoli nei secoli XVI e XVII. Economia e Società*. Rome: Tombolini.
- Coniglio, G. (1951). *Il Regno di Napoli at Tempo di Carlo V: Amministrazione e vita economico-Sociale*. Naples: Edizioni Scientifiche Italiane.
- Davis, R. (1991). *Shipbuilders of the Venetian Arsenal: Workers and Workplace in the Preindustrial City*. Baltimore, MD: Johns Hopkins University Press.
- D'Aloe, S. (1883). Catalogo di tutti gli edifizii sacri della città di Napoli e suoi sobborghi. *Archivio Storico per le Province Napoletane*, 8.
- De Munch, B. & Winter, A. (Eds.) (2012), *Gated Communities? Regulating Migrations in early Modern cities*. London: Ashgate.
- Del Treppo, M. (1972). *Els Mercaders Catalans y l'Expansió de la Corona Catalano Aragonensa*. Barcelona, Spain: Curial.
- Del Treppo, M. (1989). Stranieri nel Regno di Napoli: Le élites finanziarie e la strutturazione dello spazio economico e politico. In G. Rossetti (Ed.), *Dentro la città: Stranieri e realtà urbane nell'Europa dei secoli XII-XVI* (pp. 179-233). Naples: Liguori Editore.
- De Rosa, L. (1991). Le corporazioni nel sud della Penisola: problemi interpretative. *Studi Storici Luigi Simeoni*, 41, 49-68.
- Delumeau, J. (1979). *Vita Economica e Sociale di Roma nel Cinquecento*. Florence: Sansoni.
- Epstein, S. (1994). *Genoa and the Genoese 958-1258*. Chapel Hill, NC: University of North Carolina.
- Feniello, A. (2005). *Les Campagnes Napolitaines à la fin du Moyen Âge: Mutations d'un Paysage Rural*. Rome: Bibliothèque de l'École Française de Rome.
- Ferorelli, N. (1999). *Gli Ebrei nell'Italia Meridionale dall'Età Romana al Secolo XVIII*. Bologna: A. Forni.
- Firpo, L. (1945). *Discorsi ai Principi d'Italia ed altri scritti filo-ispatici*. Turin: Einaudi.
- Fusaro, M. (2010). Trade and Cultural Exchange in the Early Modern Mediterranean: Braudel's Maritime Legacy. In M. Fusaro, C. Heywood, & M-S. Omri (Eds.), *After Braudel: A Reassessment of Mediterranean History between the Northern Invasion and the Caravane Maritime* (pp. 1-22). London: I.B. Tauris.
- Eckstein, N. & Terpstra, N. (Eds.), (2009). *Sociability and its Discontents: Civil Society, Social Capital, and their Alternatives in Late Medieval and Early Modern Europe*. Turnhout, Belgium: Brepols.
- Epstein, S. (2008). Craft Guilds: Apprenticeship and Technological Change in Pre-industrial Europe. In S. Epstein & M. Prak (Eds.), *Guilds, Innovation, and the European Economy, 1400-1800* (pp. 26-51). Cambridge: Cambridge University Press.
- Epstein, S. & Prak, M. (2008). *Guilds, Innovation, and the European Economy, 1400-1800*. Cambridge: Cambridge University Press.
- Galasso, G. (1992). *Economia e Società nella Calabria del Cinquecento*. Naples: Guida.
- Galasso, G. (1994). *Alla periferia dell'impero: Il Regno di Napoli nel periodo spagnolo: secoli XVI-XVII*. Turin: Einaudi.
- Gioffrè, D. (1962). Il Commercio d'importazione genovese alla luce dei registri del dazio (1495-1537). In *Studi in Onore di Amintore Fanfani* (Vol. 5., pp. 113-242). Milan: Giuffrè.
- Grimaldi, D.D. (1780). *Osservazioni Economiche Sopra la Manifattura e Commercio delle Sete del Regno di Napoli: alle Sue Finanze*. Naples: G.M. Porcelli.
- Guenzi, A., Caselli, F & Massa, C. (1998). *Guilds, markets, and work regulations in Italy, XVI- XIX Centuries*. Hampshire: Aldershot.
- Kirk, T.A. (2005). *Genoa and the Sea: Policy and Power in the Early Modern Maritime Republic*,

- 1559-1684. Baltimore, MD: The Johns Hopkins University.
- Kristeller, P.O. (1956). An Unpublished Description of Naples by Francesco Bandini. In *Studies in Renaissance Thought and Letters*. Rome: Edizioni di Storia e Letteratura.
- Jacoby, D. (1997). The Migration of Merchants and Craftsmen: a Mediterranean Perspective (12th-15th Century). In D. Jacoby (Ed.), *Trade, Commodities and Shipping in the Medieval Mediterranean* (pp. 533-560). Hampshire: Variorum Collected Studies Series.
- Lanaro, P. (Ed.), (2006). *At the Centre of the Old World: Trade and Manufacturing in Venice and the Venetian Mainland, 1400-1800*. Toronto: Centre for Reformation and Renaissance Studies.
- Marino, J.A. (1992). *L'Economia Pastorale nel Regno di Napoli*. Naples: Guida.
- Mazza G.B., & Uccelli, G. (1598). *Recueil factice d'histoire généalogique et portraits de souverains de divers états*. Paris: Bibliothèque Nationale de France.
- Minieri-Riccio, C. (1863). *Studi sui fascicoli angioini*. Naples: Alberto Detken.
- Molà, L. (2000). *The Silk Industry of Renaissance Venice*. Baltimore, MD: The Johns Hopkins University Press.
- Molho, A. & Ramada Curto, D. (2003). Les réseaux marchands à l'époque moderne. *Annales H.S.S.*, 3, 569-579
- Persico, T. (1974). Diomede Carafa: uomo di stato e scrittore del sec. XV. In T. Persico (Ed.), *Gli scrittori politici napoletani dal '400 al '700*. Bologna: A. Forni.
- Ragosta, R. (1998). Conflicts and Norms in the Silkmakers' Guild in Naples in the Sixteenth to Eighteenth Centuries. In A. Guenzi, P. Massa, and F. Piola Caselli (Eds.), *Guilds, Markets and Work Regulations in Italy, 16th-19th Centuries* (pp. 211-226). Brookfield: Ashgate.
- Ragosta, R. (2009). *Napoli, Città della Seta: Produzione e Mercato in Etá Moderna*. Rome: Donzelli Editore.
- Romaniello, M. & Lipp, C. (2001), The Spaces of Nobility. In M. Romaniello & C. Lipp (Eds.), *Contested Spaces of Nobility in Early Modern Europe* (pp. 1-10). Burlington, VT: Ashgate.
- Romano, A. (1994), La condizione giuridica di stranieri e mercanti in Sicilia. In M. del Treppo (Ed.), *Sistema di rapporti ed élites economiche in Europa (secoli XII-XVII)* (pp. 113-132). Naples: Liguori.
- Sella, D. (2009). *Trade and Industry in Early Modern Italy*. Aldershot: Ashgate,
- Serra, A. (1613). *Breve trattato delle cause che possono fare abbondare li regni d'oro e d'argento dove sono miniere con applicazione al Regno di Napoli*. Naples: Scorriggio.
- Skinner, P. (2004). Material life. In D. Abulafia (Ed.), *Italy in the Central Middle Ages* (pp. 147-160). New York: Oxford University Press.
- Summonte, G. (1603), *Dell'istoria della città e regno di Napoli* (Vol. 1). Naples: Gessari.
- Tescione, G. (1933) *Statuti dell'Arte della Seta a Napoli, e la legislazione della Colonia di San Leucio*. Napoli: Consiglio Provinciale.
- Trivellato, F. (2007). A Republic of Merchants? In A. Molho and D. Ramada Curto (Eds.), *Finding Europe: Discourses on Margins, Communities, Images* (pp. 133-158). New York: Berghahn Books.
- Trivellato, F. (2008). Guilds: Technology and Economic Change in Early Modern Venice. S. Epstein & M. Prak (Eds.), *Guilds, Innovation, and the European Economy, 1400-1800* (pp. 199-231). Cambridge: Cambridge University Press.
- Trivellato, F. (2009). *The familiarity of strangers: The Sephardic Diaspora, Livorno, and Cross-cultural Trade in the Early Modern Period*. New Haven, CT: Yale University Press.
- Van Dosselaere, Q. (2009). *Commercial Agreements and Social Dynamics in Medieval Genoa*. Cambridge: CUP.
- Volpicella, S. (1880). *Giovan Battista del Tufo: Illustratore di Napoli del Secolo XVI*. Naples: Stamperia della Regia Università.
- Wallerstein, I. (1976). *The Modern World-System: Capitalist, Agriculture, and the Origins of the European World-Economy in the Sixteenth Century*. New York: Academic Press.

Archives and abbreviations

AGSim. Archivo General de Simancas.

AS. Archivio Segreto.

ASG. Archivio di Stato di Genova.

ASN. Archivio di Stato di Napoli.

ASRC. Archivio di Stato di Reggio Calabria.

Provisione. *Provisione sopra li drappi forestieri et lor gabelle: con la prohibitione delli ori falsi.*
Firenze, 1575.

Relations, Politics and Economic Choices in the Mediterranean: The Kingdom of Naples and Tunisia between the Thirteenth and the Fourteenth Centuries.

MARIAROSARIA SALERNO

The Mediterranean vocation of the kingdom, born in southern Italy in 1130, by the Norman Roger II, represents a very interesting historiographical theme, in its several shades. The aims of the numerous dynasties that ruled the kingdom, targeted from time to time from the Balkan Peninsula to Constantinople, from the Holy Land to northern Africa, with different events, more or less lasting political domains, joined by economic and cultural relations nearly forced by the territorial proximity.

This paper focuses on the thirteenth and the fourteenth centuries, from 1266 and from the ending of the Swabian domain, by the brother of Louis IX, king of France, Charles of Anjou, and aims to underline both the nearly endless interest of the rulers of southern Italy on the Maghreb zone and the influence of economic implication on political choices.

The Maghreb, the Barbary of Christian sailors, from the name of indigenous inhabitants, and in particular the eastern region, from Tripoli to Tunis, which Arabic writers called Ifrikiah, was, in those centuries, theatre of continuous conflicts among Arabic dynasties (Amari, 1854, pp. 121-122; de Mas-Latrie, 1866, p. 4). The Hafside, helped by the people, declared autonomy of Tunis in 1228, in a period of breaking up of the Almohad Caliphate domain and when Abou-Zakaria-Yahya, with the title of emir, became the first holder of an independent domain, although damaged inside by family struggles, expanded from Mauritania to Cyrenaica, from Tripoli to Djerba Islands, from Bougia to Algiers, the city disputed for a long time between the Kingdom of Tunis and that of Tlemcen, before the latter became an independent kingdom (Le Tourneau, 1969)¹. Tunis in that period could be considered the centre of western Islamism, with a huge influence, on the religious and doctrinal level: Abou-Zakaria embellished the city, with buildings, baths, created the Caravanserraglio and a big and famous library (Daoulatli, 1976; Romano, 1881-1882, p. 49; de Mas-Latrie, 1866, pp. 77-78, 185). The position of that king-

¹ See also Kably, 1993.

dom was also strategic because it was possible to control and to receive the caravans that brought gold from the countries of the southern Sahara (Guinea, Mali, Senegal and above all Ghana (Abulafia, 1983, pp. 223-270; Brett, 1969, pp. 347-364; Bovill, 1968; Levitzion, 1973). The Hafsi were able, in spite of all, to maintain the power until the fall by the Turks in the sixteenth century.

Within the relations between southern Italy and northern Africa many aspects need to be considered, that are placed in the “Mediterranean” policy of the Kingdom of Sicily. Armed attacks and territorial occupations made by the kings of Sicily in the Maghreb area, already started with Roger II, even of short duration, aimed at cleaning the way for economic arrangements and prerogatives, which were possible thanks to a peaceful context. Merchants and sailors, mainly inhabitants of the kingdom, took advantage of the favorable political conditions to extend their trades to the African coasts, in particular in the harbors of Tripoli, Mahdia and Sfax (Abulafia, 1985, p. 26-49; Houben, 1999, pp. 101-107). Maybe the first commends known in Sicily can be related to rudimental forms of commercial associations, whose texts were written in the eastern Barbary, and targeted Sicily even in the eleventh century. The mercantile environment of Palermo, moreover, had a very similar structure to Tunis (Bresc, 1986, p. 393). In 1181, during the age of William II, a ten-year peace and trade treaty was signed with the Almohad caliph; it didn’t include any political subjection for the latter but some performances, such as some privileges, probably in annual form, were granted. Through these agreements, the subjects of the king of Sicily ensured for themselves warehouses and places of worship in the main commercial towns of Ifrikiah; the north African people protected themselves from Sicilian pirates and preserved the possibility of buying exempted wheat when their harvests were insufficient (Abulafia, 1979, pp. 135-147; Abulafia, 1983, pp. 4-5; Amari, 1854, p. 516; Anonimo Cassinese as cited in Del Re, 1845, p. 470; de Mas-Latrie, 1866, p. 52; Romano, 1881-1882, pp. 45-46; Robert of Torigni, 1889, p. 285)².

With the transition from Normans to Swabians, apparently the peaceful relations with the eastern Maghreb continued, and in 1231 a new ten-year treaty was subscribed between Frederick II and Abou-Zakaria, that guaranteed freedom of trade, a mutual fight for seas security, the appointment of a Muslim prefect by the king of Sicily for the isle of Pantelleria, whose taxes were to be divided with the king of Tunis. Frederick II preferred ambassadorships and trades to the reconquest of lost territories, even if he conceded to the admiral a 10 per cent of the profit on the “old” and “new” taxes, where in the “old” ones there could be a tribute paid by Tunis, which in the following Angevin documentation results already paid to the Emperor Frederick II. At that time Abu-Zakaria reorganized the African trade with Christian merchants. The interests of the Frederician Curia with the emir weren’t just a mere treaty, but there were also the huge gains derived from the selling of wheat on Maghreb markets. Frederick II went as far as banishing private selling

² Ibn al-Athîr, BAS I, p. 499, An-Nuwayri, BAS II, p. 160, al-Marrakishi, BAS I, p. 514.

and he also used the incomes to buy personal objects, like foals, Arabian horses, leopards and elephants for his seraglio in Lucera. It doesn't seem a coincidence that the coinage of gold Frederician *augustales* started in the same year of the stipulation of the treaty with Tunis (Abulafia, 2001, p. 19; de Mas-Latrie, 1866, pp. 123-124, 152-155; La Mantia, 1922, pp. 171-173; Romano, 1881-1882, pp. 50-52)³.

The good relationship between Swabians and Tunis didn't hesitate to show up when Abou-Abd-Allah el-Monstancer, son and successor of Abou-Zakaria in the three Kingdoms of Tunis, Bougia and Tripoli, didn't recognize Charles of Anjou's ambitions on the Kingdom of Sicily. He, therefore, didn't feel obliged to pay the tax anymore and sustained the partisans of the Swabians, like Henry and Frederick of Castile, passed on his side, who organized an army in Tunis that in 1269 landed in Sicily, helped by men sent by the same Monstancer. The deed failed and only Frederick of Castile managed to go back to Tunis, probably because Charles of Anjou knew the relations between Tunis and the rebellions (de Mas-Latrie, 1866, pp. 129, 135; Ibn-Khaldoun, 1854, p. 347; Lower, 2006, pp. 508, 511-512; Romano, 1881-1882, pp. 54-55).⁴ It seems that in those years the submission of the isle of Pantelleria to Sicily took place, interrupting the cession of the half of gains to the king of Tunis.

A few years after Charles of Anjou's accession to the throne, in 1270, the relations between the Kingdom of Sicily and Tunisia took the appearance of a crusade, the one that is commonly considered the last one of traditional crusades, the second one organized by Louis IX, king of France, Charles's brother (Le Goff, 1996, p. 138; Runciman, 1966, pp. 904-923; Salerno, 2011, pp. 205-221). There were different positions and theories by contemporary authors on the motivations for this crusade: the conversion of the emir by the pious Louis IX; the obstacles put by Tunisians on the free sailing in the Mediterranean Sea; the conquest of Tunis as a base to better reconquest the Holy Land. This shows their ignorance of geography and of real distances among Tunisia, Egypt and Palestine. Other authors thought that Charles of Anjou diverted the crusade to Tunis to regain the tributes due by the emir. The most plausible hypothesis is the first one, the conversion of the emir, and then to get to the Holy Land (Kedar, 1991, pp. 210-211; Lefevre, 1977; Sternfeld, 1896, p. 243). On the Arabian side, al-Maqrīzī says that the king of France moved against Tunis, taking advantage of the famine that there was (al-Maqrīzī as cited in Gabrieli, 1969, p. 298).

Charles of Anjou showed interests in the executive developments of the deed promoted by his brother; but only in 1269, with the ultimate defeat of Swabian partisans, he showed concrete initiatives. These events foreshowed a change of direction in the crusade: Charles of Anjou sent a Dominican friar, Berengario, to Tunis, probably to calm the conflict based on the failed payment of the tax; contemporarily there was a Tunisian Embassy in France, confirmed also by Arabian sources, in which Louis IX said how much he cared about the conversion of the emir. The change of route towards Tunis, justified as a short step to give the emir

³ HB, III, p. 276.

⁴ RA, IV, p. 175; RA, II, p. 175; RA, II, p. 161; RA, V, p. 106.

the occasion to convert, was announced by Louis IX only after he left France, and Charles of Anjou had left Naples to Palermo (Le Goff, 1996, p. 237; Lefevre, 1977, pp. 26, 28; Salerno, 2011, p. 212).

The capture of Cartagena represented the only important war episode of the whole deed, and Charles of Anjou, although informed about the moves in Tunisia, sustained his brother's army from afar, helping even private merchants willing to send provisions to Tunis. Only after 22 of August he decided to leave for Africa, but he arrived when his brother Louis had already died, for dysentery or typhus.

Charles of Anjou immediately showed economic worries about continuing with the feat, and it was concluded with a fifteen-year treaty among el-Monstancer, Philip the Bold new king of France, the same King Charles and Theobald, king of Navarra. The agreements aimed at restoring the conditions existing before the crusade, both economic and religious, so the emir obtained the departure of the crusaders and the regain of the occupied territories, against the payment of a war indemnity; free trade in Tunisia for Christian merchants and the right to preach and pray in their churches for Christian priests (Pietro di Condé as cited in L. d'Achery, 1723, p. 668A; Salerno, 2011, p. 215). According to the conventions, slaves must be freed, goods were to be returned to their owners, security should be granted on land and on sea, wrecked ships in their own territories belonging to the others must be helped, others' enemies must be sent away from their own kingdoms (like Charles of Anjou's enemies from Tunis). The king of Sicily gained the most of the material advantages from the treaty: a war indemnity; the payment of the back tributes of Sicily, re-established and doubled compared with the ones of Frederick II's period (de Mas-Latrie, 1866, pp. 104, 137-138; La Mantia, 1922, pp. 176, 179-180; Romano, 1881-1882, pp. 58-59; Salerno, 2011, pp. 216-217). Charles of Anjou seemed more interested in regaining, for himself and his subjects, old privileges and serenity, than continuing with the war deed started by his brother in Tunis. It is to be considered that the king of Sicily raised in Africa non just the famous tribute, but also other proceeds and rights, maybe already existing in Norman Age: the tallage of the warehouse and the one of the consulate, that he contracted out from the 1 February of each year to the following 31 January at the price of 90 gold ounces. The maintenance costs of the warehouse were due by the emir of Tunis, and from there the agents of the king of Naples oversaw that the pacts of 1270 were respected, raised proceeds and incomes from the warehouse and the consulate and dealt all the commercial affairs directly managed by the Curia. As in the past, at the centre of this affairs there was the selling of wheat in African markets, with all possible consequences by the possibility of less or more gain and by the market prices in Barbary, not always with a correct mercantile policy, as when in public auctions false interested people appeared to raise prices of goods or of the same warehouse tallage⁵. Even Charles I, like Frederick II, used wheat as a mean of po-

⁵ See, for example, RA, VII, pp. 90, 96; RA, XIII, pp. 32, 94, 165, 167. See also Camera, 1876; Romano, 1881-1882.

litical pressure with tight control by his agents on wheat flow and private exporters (Bresc, 1986, p. 553)⁶.

It seems that Tunis paid regularly at least until the Sicilian Vespers rebellion, in 1282, when the emir took his chance to stop paying the tributes. The Angevin Curia, that was so cautious on this topic, annually sent royal commissioners to Tunis to raise money, together with a notary for rogation of the act, an expert to verify the coins and an interpreter (de Mas-Latrie, 1866, p. 157)⁷. Charles of Anjou, therefore, used his position to act in an authoritarian way on Tunis, as when, in 1273, arrested and sequestered Genoese merchandise in Apulia and in Sicily and ordered the emir to do the same. Diplomatic relations between the two kingdoms were very active during the first Angevin and during his son's vicarship, the future Charles II. These relations are witnessed by the numerous visits made by Tunisian ambassadors to Naples. Among the economic reasons that boosted these relations it's possible to list, for example, the purchase of 700 sheep and 300 young good-wood rams in Barbary, ordered by Charles I in 1279 to improve races and so wool fabrics created in the kingdom. However, ambassadorships didn't concern only political and economic interests, but also cultural ones: Charles I, supporter of studies, sent ambassadors to the emir of Tunis to receive a treaty on fevers that was ordered a Hebrew to translate into Latin (Amari, 1876, pp. LV-LVI; Imperiale di Sant'Angelo, 1926, p. 152; La Mantia, 1922, p. 182; Romano, 1881-1882, p. 63)⁸.

Charles I died in 1285, when the treaty expired, when Sicily had by then passed to the House of Aragon. The isle represented, until that moment, the bridgehead among Norman, Swabian, Angevin kingdoms and Maghreb, the starting point of every initiative concerning that Mediterranean area. Its loss brought several changes in Angevin kings' behaviour and opportunities, and even in the conquest by Peter III of Aragon. The latter had already tried to expand his influence in that area some years before, entering with success in dynastic affairs of Tunis and later, failing, even in those of the throne of Bougia (de Mas-Latrie, 1866, pp. 143-145; Mirto, 2001, pp. 25-46; Ibn-Khaldoun, 1854, p. 385; Runciman, 1971).

After the transit of King Peter in Sicily, there were two years of turbulence in Africa, in which the throne of Tunis was disputed between Monstancer's descendants and Bougia created an independent reign until 1318, in a time in which the payment of the tribute was interrupted, because of the new Sicilian situation (de Mas-Latrie, 1866, p. 146; Ibn-Khaldoun, 1854, pp. 392, 394, 396, 399; Muntaner, 1844; Romano, 1881-1882, p. 65). The Angevins, in the beginning, didn't try by force nor by the means of rights to regain the payment of the tribute, they just asked the emir of Tunis to borrow some amounts of money, in particular to boost the war against the House of Aragon. They never returned that money. From one of the requests made by Charles, prince of Salerno and vicar of the kingdom, it is

⁶ RA, XIII, p. 30.

⁷ RA, XIII, p. 114; RA, X, p. 213; RA, XIX, pp. 206-207; RA, XXII, p. 176; RA, XXV, p. 5; RA, XXVI, p. 269.

⁸ RA, XXI, pp. 177, 208.

possible to verify that a new pact between Naples and Tunis had been established from 1277 to 1279, when Jahya, threatened by his uncle Abu Zakaria, probably wanted to ensure the protection of the Angevin with a treaty. Nearly at the same time the future Charles II protected a certain Peter, the king of Tunis's son, maybe one of the outsiders of civil wars, to counterbalance the uncertain faith of African emirs. However, the death of Charles I and the captivity of the prince of Salerno, his successor, didn't help the achievement of the tribute. Around 1300, Charles II sent to the Emir Abu Acida, the admiral Roger of Lauria, who by that time was at his service, to try to achieve the tribute, but with no results (Amari, 1854, p. 631; Romano, 1881-1882, p.66)⁹. Peter III of Aragon, from his privileged position as king of Sicily, continued his intervention in the Maghreb area that ended in 1285 with a peace and trade treaty with Abou-Hafs, new king of Tunis, that brought a relative point to the tribute of Sicily, that maybe Aragonese received for several years. Peter III died at the end of 1285, the same year of Charles I; Sicily was divided from the Kingdom of Aragon and the tribute, in particular after the release of Charles II, it was harshly disputed by the two kingdoms, so much so that the king of Tunis didn't pay it to both (de Mas-Latrie, 1866, pp. 154-155, 286-290; La Mantia, 1922, pp. 185-188)¹⁰. Also James II of Aragon and Sicily, for power and proximity, obtained loans of amounts of money from Tunis to pay weaponry against the Angevins, in return for services for the emirs; even the isle of Pantelleria, in the meanwhile, had become part of his domain (de Mas-Latrie, 1866, pp. 291-296; Romano, 1881-82, pp. 66-67)¹¹.

The tribute wasn't mentioned in the peace of Caltabellotta (1302) between the two kingdoms, so, some years after, to resolve the question was requested the arbitrate of James II, king of Aragon, in a period in which Sicily was newly dismembered. On that occasion he declared that the tribute appertained to Charles II, as *rex Siciliae*; Frederick of *Trinacria* could have asked for another one, even by force, for the geographic proximity. This judgement didn't have practical effects for Naples. In fact, the Angevins didn't do anything to force the king of Tunis to declare himself their tributary: Charles II died in 1309 and his son Robert, involved in other deeds, didn't cope with the problem (de Mas-Latrie, 1866, p. 156; La Mantia, 1922, pp. 190-191; Romano, 1881-1882, pp. 70-72).

Even the control on the isle of Djerba, as a base for political and economic pressure in the whole area, was an object of interest by the Angevins and Aragonese, that contended it with Tunis, taking advantage of the division of people into two rival tribes, only one agreeing with Tunisian domain. The isle was occupied between the 1284 and 1285 by Roger of Lauria, then admiral of Aragon, who, only ten years later, at the service of the king of Naples, strengthened his possession, put it under papal sovereignty and regained it as a hereditary fief. The successors of the admiral kept the power with great difficulties, to defend themselves from the at-

⁹ RA XXVII, pp. 322, 329, 331, 449.

¹⁰ The text of the treaty is in de Mas-Latrie, 1866, pp. 286-290.

¹¹ *Biografia del Sultano Al Mâlik al Mansûr*, BAS I, cap. XLIII, pp. 545-568.

tacks of the emirs of Tunis, so that they were helped both by the king of Sicily and by the king of Naples, Robert of Anjou, their feudal lord. In the end, they preferred to give Djerba in the form of usufruct to Frederick of Sicily, who, between 1310 and 1311, intervened with his army; settled there the Catalan Raymond Muntaner, as captain, for three years, after which the isle went back in the direct domain of the king (Bartolomeo da Neocastro as cited in Del Re, 1845, pp. 509-510; de Mas-Latrie, 1866, pp. 157-158; Muntaner, 1844, chap. CCXLVIII, CCXLIX, CCL, CCLI, CCLII, CCLIII, CCLIV, CCLV)¹².

In 1313 the king of Sicily managed to set a fourteen yearlong peace with Tunis, in coincidence with new hostilities with the Angevins, who tried, with no success, to occupy Djerba and to move the Aragonese away from Africa. Actually, the king of Sicily through his position, guaranteed influence and prerogatives in that area, as when he kidnapped a Saracenic prince on his way to Tunis, and tried to use it to promote one of his candidates to the throne (Bartolomeo da Neocastro as cited in Del Re, 1845, p. 510; Muntaner, 1844, chap. CCLV). In addition, around 1317, he was given a new tribute by Tunis, to guarantee exportations of Sicilian wheat and to protect from pirates, in a period in which there were many Christians in the Maghreb city, under the double flag: Sicilian and Aragonese (de Mas-Latrie, 1866, pp. 159-161; Gregorio, 1833, p. 529sgg; La Mantia, 1922, pp. 195-197). Angevins attempts to stem that hegemony came off only in 1336, when after a rebellion of the inhabitants backed by the king of Tunis and by Robert of Anjou's ships, the king of Sicily lost Djerba (de Mas-Latrie, 1866, pp. 165, 220; Romano, 1881-1882, p. 78).

Tunis policy, despite the continuous dynastic problems, aimed at booster trade, for example through exempted exportations, in a context of respect even religious for those Christians who lived and traded there, but that never permitted them to preach outside their churches (El-Kairouani, 1888, p. 240; Pegolotti, 1340, chap. XXVII).

In the years of Robert of Anjou, between Tunis and the Kingdom of Naples remained only a commercial bond, with less possibilities by the *Curia Regis* to control and a predominant role of private actors, with whom the king undertook mercantile maritime operations (Caggese, 1922, p. 532; Yver, 1903, p. 33).

Therefore, despite the loss of Sicily, eastern Maghreb harbours continued to be attended by ships from Trani, Barletta, Manfredonia, Monopoli, Bari, Taranto and Reggio. Amalfi, despite the decadence compared to the past, had in thirteenth and fourteenth centuries an active traffic, even from Tunis, where some ships were captured by pirates (Abulafia, 1991, pp. 9-11; Bautier, 1958, pp. 181-194; de Mas-Latrie, 1866, p. 99; Romano, 1881-1882, p. 72; Yver, 1903, p. 147)¹³.

The sailors of Ischia, merchants and pirates at the same time, arrived up to Gabes and Djerba: the ships departed from Angevin harbours, went to Tripoli to load wax, leather, spices brought there by caravans. In a document of 1333-1334 there are listed the goods loaded on Neapolitan ships, captured by Catalan corsairs along the coasts of Barbary such as: wheat, barley, oil, Greek and Latin wine,

¹² About people of Djerba see Ibn al-Athîr, BAS I, p. 461.

¹³ RA, XIX, p. 40; RA XXXVIII, p. 101.

fruits, fabrics, feathers and also slaves. All of them, apart from the slaves, are the ones listed by Balducci Pegolotti in his *Pratica della Mercatura*, written between 1339-1340. However, he may have given to Naples, the capital of the kingdom, an excessive role, giving to it the part of exportations to eastern Maghreb of walnuts, hazel-nuts, wine and importations in exchange for gum, dates, wax, cotton, silk, raw-wools and leather (Yver, 1903, p. 137). In the fourteenth century there are testified in the capital even red coral batches coming from Tunis, that Tunisian sailors probably had collected in Sicilian waters (de Mas-Latrie, 1866, p. 223).

From northern Africa sailors of Djerba traded up to the southern Tyrrhenian, and found a bad welcome by the inhabitants and often loaded ships from Maghreb were captured by the subjects of the king of Naples, with the pretext that they could be directed to enemies of the kingdom (Caggese, 1922, pp. 599-600). A part from regular trade, the African coast represented for the whole fourteenth century a supplier of slaves in the south of Italy; captured between Tripoli and Tunis, coming from the islands, they found themselves in African slaves markets of Salerno, Amalfi and in the zone of Palermo (de Mas-Latrie, 1866, p. 157)¹⁴. That market was frequently hidden by governments, despite the treaties: Frederick II permitted "racing" ships, with the authorization to attack and take the loot of ships belonging to enemy states; Peter III of Aragon and Sicily gave to the royal Treasury a fourth of the stolen goods in piracy and sold in his kingdom; slaves were captured during incursions, led by the famous admiral Lauria too, sometimes approved in the crusades context against infidels (Bresc, 1986, pp. 440-455; La Mantia, 1922, pp. 205-206; Romano, 1881-1882, pp. 69-72)¹⁵.

If Charles I managed to balance exportation licences for the subjects of the kingdom, gradually the major part of commerce from the south of Italy to Maghreb was boosted mainly by foreigners. Florentine people, thanks to the preferential relations with the Angevins, and Genoese people were actually engaged in the traffic of wheat and gold with those regions. Later Sicilian Vespers, Catalans and Sicily (in particular the harbours of Trapani and Palermo) were at the centre of that traffic. Directed to the Kingdom of Tunis, through Sicilian harbours, were transported wine and dried fruits of the principedom, Calabrian wines from the Gulf of S. Eufemia brought by Catalans, drapes brought by Genoese, but it was possible to do good affairs mainly during famine in Tunis or Bougia, with the selling of wheat, in which Florentines (such as: Bardi and Peruzzi) were predominant between the end of thirteenth century and 1340: they took advantage, with their partners, from trade in gold more than others. In the late thirteenth and in the early fourteenth century, Sicily exported even cheese and salted meat in northern Africa, but then those products were just marginal in commerce. In Sicilian harbours, halfside gold coins (dinars or 'doubloons') arrived and were sorted, oil brought from Tunis and from the small fleet of Hebrew and Muslim merchants of Djerba, honey, butter, linen of Bougia, luxury products, carpets, blankets, leather, pillows, furs, cloaks,

¹⁴ See Verlinden, 1977.

¹⁵ HB V, p. 277.

table cloths, because Maghreb was considered a land of expert artisans. However, traffic and courses had to take into consideration possible wars, as between Bougia people and Tunis, or as in Djerba (Abulafia, 1987, pp. 53-75; Biblioteca del Bollettino Storico Pisano, 1987; Buccellato, 1983; Carini, 1893, pp. 489, 522-523, 591; Epstein, 1996, p. 293; Pegolotti, chap. XXVIII; La Mantia, 1922, p. 194)¹⁶.

Because of what has been said until now, there was a mutual interest from the Norman Age between southern Italy and Tunis, backed, when possible, by political actions. The attractive was determined by the geographic proximity of the southern kingdom, and of Sicily in particular, to the Tunisian coast, so in addition to relations and events related to politic situations, there were more lasting contacts, imposed by security and commercial reasons, by the continuous ghost of famine impending on Tunis for the scarcity of cereals. These reasons determined the need of some agreements. Angevin policy, even if interested in political prerogatives and controls in eastern Maghreb, was mainly aimed at guaranteeing in the future the safeguard of economic and commercial interests, in a direct way during the reign of Charles I and even more indirectly later. So, after the loss of Sicily, there was a preponderance of private interests, in which Tuscans, Genoens and Catalans prevailed compared to the subjects of the king. For their part, the emirs of Tunis, for the supply of wheat and the sea security, tried to keep good relations with Angevins and Aragonese, favouring more who controlled the nearby Sicily, but going as far as lending money to both, in different moments, to arm one against the other.

References

- Abulafia, D. (1983) Maometto e Carlo Magno: le due aree monetarie italiane dell'oro e dell'argento. In *Storia d'Italia: Economia naturale, economia monetaria*, (vol 6., pp. 225-272). Turin: Einaudi.
- Abulafia, D. (1983). The Crown and the Economy under Roger II and His Successors. *Dumbarton Oaks Papers*, 37. 1-14.
- Abulafia, D. (1985). The Norman Kingdom of Africa and the Norman Expeditions to Majorca and the Muslim Mediterranean. *Anglo-Norman Studies: Proceedings of the Battle Conference*, 7. 26-49.
- Abulafia, D. (1987). A Tyrrhenian Triangle: Tuscany, Sicily, Tunis, 1276-1300. In C. Violante (Ed.), *Studi di storia economica toscana nel Medioevo e nel Rinascimento in memoria di Federico Melis* (pp. 53-75). Pisa: Pacini.
- Abulafia, D. (1991). *Le Due Italie: relazioni economiche fra il Regno normanno di Sicilia e i comuni settentrionali*. Naples: Guida.
- Abulafia, D. (2001). *I regni del Mediterraneo occidentale dal 1200 al 1500. La lotta per il dominio*. Rome-Bari: Laterza.
- Amari, M. (1854). *Storia de' Musulmani di Sicilia* (Vol. 1). Florence: Felice Le Monnier.
- Amari, M. (1876). *La Guerra del Vespro Siciliano* (Vol. 1). Florence: Cugini Pomba e Comp.
- Bautier, R-H. (1958). La marine d'Amalfi dans le trafic méditerranéen du XIVe siècle. *Bulletin Philologique et Historique*. 181-194.
- Bovill, E.W. (1968). *The Golden Trade of the Moors*. Oxford: Oxford University Press.
- Bresc, H. (1989). Un monde méditerranéen: économie et société en Sicile. *Revue belge de philologie et d'histoire*, 67(4). 838-839.

¹⁶ See Bresc, 1989.

- Brett, M. (1969). Ifriqiya as a Market for Saharan Trade from the Tenth to the Twelfth Century A.D. *The Journal of African History*, 10(3), 347-364.
- Buccellato, R.M.D. (1983). *Fisco e società nella Sicilia aragonese. Le pandette delle gabelle regie del XIV secolo*. Palermo: Assessorato ai beni culturali.
- Caggese, R. (1922). *Roberto d'Angiò e i suoi tempi*. Florence: Bemporad.
- Camera, M. (1876). *Memorie storico-diplomatiche dell'antica città e ducato di Amalfi* (Vol 1). Salerno: Stabilimento tipografico nazionale.
- Carini, I. (1893). De rebus Regni Siciliae (9 settembre 1282—26 agosto 1283). Appendice ai documenti inediti estratti dall'Archivio della Corona d'Aragona. *Documenti per servire alla storia di Sicilia*, 5(1), pp. 489, 522-23, 591). Palermo: The Articles of Association.
- Cassinese, A. Del Re, G. (Ed.), (1845). *Cronisti e scrittori sincroni del regno di Napoli*. Naples: Iris.
- d'Achery, L. (1723). Pietro di Condé. In *Spicilegium sive collectio veterum aliquot scriptorium* (Vol. 3). Paris: Apud Montalant.
- Daoulatli, A. (1977) Tunis sous les Hafside. *Revue de l'Occident musulman et de la Méditerranée*, 23(1), 236-238.
- De Mas Latrie, M.L. (1866). *Traité de paix et de commerce et documents divers concernant les relations des chrétiens avec les Arabes de l'Afrique septentrionale au Moyen Age*. Paris: Henri Plon.
- Epstein, S. (1996). *Potere e mercanti in Sicilia. Secoli XIII-XVI*. Turin: Einaudi.
- Gabrieli, F. (1969). al-Maqrīzī. In *Storici arabi delle crociate*. Turin: Einaudi.
- Gregorio, R. (1833). *Considerazioni sopra la storia di Sicilia* (Vol. 2). Palermo: Lorenzo Dato.
- Houben, H. (1999). *Ruggero II di Sicilia. Un sovrano tra Oriente e Occidente*. Rome-Bari: Laterza.
- Ibn-Khaldoun. (1854). *Histoire des Berbères*. In W. M. De Slane (Ed., & Trans.). Alger: Imprimerie du Gouvernement.
- Imperiale di Sant'Angelo, C. (Ed.), (1926). *Annali genovesi di Caffaro e de' suoi continuatori*. Rome: Istituto Storico Italiano.
- Kably, M. (1993). Pouvoir universel et pouvoirs provinciaux au Maghreb dans la première moitié du XIIIe siècle. *Revue du monde musulman et de la Méditerranée* 68(1), 215-224.
- Kedar, B. Z. (1991) *Crociata e missione. L'Europa incontro a l'Islam*. Rome: Jouvence.
- La Mantia, G. (1922). La Sicilia e il suo dominio nell'Africa settentrionale. *Archivio Storico Siciliano*, 44, 171-173.
- Le Goff, J. (1996). *San Luigi*. Turin: Einaudi.
- Le Tourneau, R. (1969). *The Almohad movement in North Africa in the twelfth and thirteenth centuries*. Princeton: Princeton University Press.
- Lefevre, R. (1977). *La crociata di Tunisi del 1270 nei documenti del distrutto archivio angioino di Napoli*. Rome: Italo-African Institute.
- Levitzion, N. (1973). *Ancient Ghana and Mali*. London: Methuen Publishing.
- Lower, M. (2006). Tunis in 1270: A Case Study of Interfaith Relations in the Late Thirteenth Century. *The International History Review*, 28(3), 508-512.
- Mercier E. (1888). *Histoire de l'Afrique septentrionale (Berbérie) depuis les temps les plus reculés jusqu'à la conquête française (1830)*. Paris: Ernest Leroux
- Mercier, E. (1888). *Histoire de l'Afrique septentrionale*. Paris: Leroux.
- Mirto, C. (2001). L'insurrezione del Vespro e la Communitas Siciliae. *Archivio Storico Siciliano*, 27(1), 25-26.
- Muntaner, R. (1844). Cronaca, cap. XXXI. In *Cronache catalane del secolo XIII e XIV*. Florence: Galileiana.
- Pegolotti, F. B. (1340). Pratica della Mercatura. In *Biblioteca Riccardiana*. Florence: Biblioteca Riccardiana.
- Robert of Torigni. (1889). The Chronicles of Robert of Torigni. In R. Howlett (Ed.), *Chronicles of the reigns of Stephen, Henri II, and Richard I* (Vol.4, pp.285). Cambridge: Cambridge University Press.
- Romano, G. (1881-1882). Saggio intorno alle relazioni tra l'Italia meridionale e Tunisi sotto i re Normanni, Svevi e Angioini fino all'anno 1336. *Estratto dalla cronaca del R. Liceo Filangieri di Monteleone*. 49.
- Runciman, S. (1966). *Storia delle crociate*. Turin: Einaudi

- Runciman, S. (1971). *I Vespri siciliani*. Bari: Dedalo.
- Salerno, M. (2011). Luigi IX il Santo, Carlo I d'Angiò e la crociata di Tunisi del 1270. In *Miscellanea di studi storici* (pp. 205-221). Soveria Mannelli: Rubbettino.
- Sternfeld, R. (1896). *Ludwig des Heiligen Kreuzzug nach Tunis, 1270, und die Politik Karls I. von Sizilien*. Berlin: Ebering.
- Verlinden, C. (1977). *L'esclavage dans l'Europe médiévale*, vol. 2, *Italie, Colonies italiennes du Levant, Levant latin, Empire byzantin*. Ghent: Royal University of Ghent.
- Violante, C. (1987). *Biblioteca del Bollettino Storico Pisano. Collana storica*, 33. 53-75.
- Yver, G. (1903). *Le commerce et les marchands dans l'Italie méridionale aux XIII et XIV siècle*. Paris: Fontemoing.

Abbreviations

- BAS. Amari, M. (1880-1). *Biblioteca arabo-sicula*. Rome: Ermanno Loescher.
- RA. *I registri della cancelleria angioina*. (1963). Edited by R. Filangieri and Napoli Archivists. Naples: L'Accademia Pontaniana.
- HB. Huillard Bréholles, J.L.A. (1852-61). *Historia diplomatica Friderici secundi* (Vols. 6). Paris,: Excudebat Henricus Plon.

Part II

Modern Mediterranean

Procuratorial Networks: Reconstructing Communication in the Early Modern Adriatic

STEPHEN SANDER-FAES

1. Introduction.

For centuries the history of the early modern Adriatic, also known as the Gulf of Venice, was inextricably linked with the fortunes of the Republic of St Mark. Notwithstanding her long-term and supra-regional impact over large areas of the (eastern) Mediterranean, historians overwhelmingly focused their attention on Venice proper¹. More often than not the historiography of her maritime state, also known as the *Stato da mar* or *Oltremare*, continues to be confined by today's linguistic and national borders². Additionally, modern scholarship has been heavily influenced by other political concerns: First by imperialistic and nationalistic claims of dominion during the second half of the 19th century and the first decades of the 20th century and, second, by Fascism's aspirations in the period leading up to the Second World War. Both sides at least partially founded their arguments on the Adriatic's Venetian past³. As a consequence of developments during the second half of the past century, Venice proper and her various inhabitants gained more prominence (Thiriet, 1959). The shared history of the 'Venetocracy' in the eastern Mediterranean, however, was mainly left to scholars of Greece or former Yugoslavia.⁴ It has only been over the course of the past three to four decades that new approaches have emerged, emphasising the (dis-)continuities of the expansion of Latin Europe during the Middle Ages and the Early Modern Period (Balard, 1998; Balard & Ducellier, 1998).

The present contribution focuses on the various aspects of 'communication' within Venice's maritime state in the 16th century (Saint-Guillain & Schmitt, 2005,

¹ On Venice, see Cessi, Giovanni & Knapton, 1986-1992; Crouzet-Pavan, 2002; Cozzi, 1982; Lane, 1973; Martin & Dennis, 2000; Italian Encyclopedia Treccani, 1991-2002.

² In general, see O'Connel, 2009. On Venice's Adriatic possessions see Ivetić, 2005; Pederin, 2001.

³ For example, see De Benvenuti, 1944; Praga, 1954; Novak, 1944.

⁴ On the Venetian Adriatic see Ivetić, 2000; 2005. On Venetian rule in the eastern Mediterranean see the articles by Karapidakis, Kitromilides & Papadia-Lala, 2001.

pp. 215-225; Schmitt, 2009, pp. 77-101). By emphasising the importance of an as-yet all but neglected source, procuratorial appointments, additional layers of pre-modern exchange can be reconstructed. The approach is twofold: In a first section, the focus rests on the *procura*, a type of contract, the characteristics of which render it eminently suitable for quantitative analysis. Based upon these elaborations, the second part consists of a number of examples drawn up in Zadar⁵ between the two Ottoman-Venetian wars from 1537 to 1540 and 1570 to 1571, respectively. The subsequent remarks are based upon a total of 930 individual procuratorial appointments, preserved in the Croatian State Archive in Zadar (*Državni arhiv u Zadru*), from this period⁶.

The focus of the present paper rests on Venetian Dalmatia and its principal city, Zadar. Eager to reassert control over her vital shipping lanes, the Republic of St Mark took advantage of the Hungarian succession crisis⁷. Over the course of the 15th century Venice reacquired most communes along the eastern shore of the Adriatic and Zadar became the ‘metropoli et chiave di quella provintia’ (Ljubić, 1880, pp. 1-30)⁸. The newly-organised dual province of Dalmatia-Albania comprised areas of present-day Albania, Croatia, and Montenegro⁹ and its urban societies were embedded within the larger structural framework of Venetian rule over both the Italian *Terraferma*¹⁰ and her maritime state¹¹. Simultaneous developments

⁵ The present article uses contemporary toponyms. On the use of ‘Venetian’ in the *Stato da mar*, see Eufe, 2006. On language in the Adriatic see Graciotti, 1997; Krekić, 1997); Michael, 2009; Šimunković, 1997.

⁶ The present article incorporates contracts written by the following 15 public notaries from Zadar and whose books are preserved in the *Državni arhiv u Zadru* (DAZd, Croatian State Archive in Zadar), *Spisi zadarskih bilježnika* (SZB, Manuscripts of Notaries from Zadar): AM, active from 1540-1551; CC, 1567-1569; DC, 1551-1566; FT, 1548-1561; GC, 1562-1564; HM, 1567-1569; JM, 1545-1569; JMM, 1540-1554; MAS, 1544-1548; NC, 1558-1567; ND, 1540-1566; PB, 1540-1569; PS, 1545-1551); SB, 1556-1565, & SM, 1555-1567; Hence DAZd, SZB, and the respective notary’s name(s) are abbreviated. See also Kolanović, 2006-2007.

⁷ The present paper does not cover events prior to the second Venetian dominion. For the preceding Hungarian period see (in order), Engel, Kristó, & Kubinyi 2008; Engel, 2001.

⁸ As syndic referred to by Antonio Diedo in his *Relatione del sindacato di Dalmatia et Albania*, written in 1553. For an overview of Venetian expansion cfr. Arbel, 1996; Engel, 1996; Novak, 1944.

⁹ For the late medieval and early modern Adriatic see Doumerc, 2001. On Venetian Albania see Schmitt, 2001; on Dalmatia start with Raukar, 2008.

¹⁰ See Rubinstein, 1973.

¹¹ Extending from the southern tip of Istria to Cyprus, see for example, Arbel, 1996; Doumerc, 2001; Borsari, 1997. The distinction between *Terraferma* and *Stato da mar* is rather arbitrary as the Venetians applied virtually the same ruling policy of amending existing legislature and institutions to serve her needs while keeping in place (most) older legislation throughout her territories. This policy was marked by the use of the title *rector/retto* and *comes/conte* in Dalmatia and Pula while Venice’s governor in all places northwest of the latter used the title *podestà*. Introduced in 1440, it coincides more or less with the usage of these titles. It must be noted, though, that technically Pula was part of the *Terraferma*, hence the reference to the arbitrariness of the distinction. Also, this stands in considerable contrast to Venice’s other name for its maritime state, *Oltremare*, which signifies the geographical distance between her eponymous lagoon and her dependencies overseas. See Cozzi, 1997. On Istria, see Ivetić, 2000; Viggiano, 1994. See also Georgopoulou, 2001.

in the neighboring Apennine peninsula in the medieval and early modern periods precipitated cultural, legal, linguistic, and social changes which also came to influence the Dalmatian coast¹².

The most important of these changes was the almost complete replacement of the Dalmato-Romanic population by immigrant Slavic peoples during the Middle Ages. In matters confessional, however, Dalmatia's adherence to Roman Catholicism did not wane (Šanjek, 2008). Another structural element concerned Venice's claims of dominion over her eponymous gulf after the turn of the first millennium, which were only briefly interrupted for half a century after the Peace of Zadar (1358)¹³. Consequently, Dalmatian urban societies resembled Italian cities in general and Venice in particular, especially in terms of social hierarchy and overall organisation. On top was the Venetian administration, assisted by the local urban nobility, which had also separated itself by legislative means from the general populace over the course of the Middle Ages¹⁴. Alongside these two distinct groups were the various strata of commoners containing a variety of administrative, ecclesiastical, intellectual, and mercantile 'elite citizens'¹⁵.

2. Procuratorial Appointments

Between 1540 and 1570, the year in which the Cyprus War broke out, Zadar's 15 notaries wrote a total of 930 individual *procurae*, which have been preserved by the Croatian State Archive. The instruments are comparable to those stipulated elsewhere in the Mediterranean Basin, in turn allowing for comparisons¹⁶. In general terms, they consist of three parts, the preamble (*invocatio*), the various clauses, and the valediction (*valedictio*) at the end of the contract¹⁷.

The preamble consists of the name of both the Venetian Doge and the count of Zadar, the indiction (*indictio*), and the name of the public official present at the time of stipulation¹⁸. A formal preamble read as follows:

¹² See Jacoby, 1998; 1989; 1973. On Venetian Crete, in many ways the 'exception' (O'Connell, 2009) to Venetian rule overseas, see McKee, 2000.

¹³ On the Hungarian suzerainty, see note 9. On Venice's medieval claims see Ortalli, 2009.

¹⁴ The relevant passages in Zara's statutes clearly state that «[q]uod admittantur ad Consilium illi quorum avus paternus et pater fuerunt de Consilio» (Kolanović & Mate, 1997). This was in stark contrast to the nobles of the coastal hinterlands in the western Balkans, who strongly resembled those of Croatia-Hungary (Engel, 2001).

¹⁵ See Grubb, 2002.

¹⁶ A *procura* describes the unilateral conferment of legal powers with or without explicit mandate as to the duties of the executing party, the so-called procurator; these powers, if not assigned for a specific period of time and/or task, typically lasted until the death of one (or both) contracting parties or the stipulation of any new notarial act stating otherwise. See Jungwirth, 2006.

¹⁷ On Venice's notaries see Pedani 1996; Cracco, 1961; Guzzetti, 1998. On the normative framework Kolanović & Križman, 1997.

¹⁸ Without whom no instrument could be validated (Kolanović & Križman, 1997).

In Christi nomine amen, Anno ab eius Nativitate Millesimo quingentesimo quadragesimo octavo, Indictione sexta die vero secundo mensis octobris, Temporibus serenissimi Principis et domini excellentissimi Domini Francisci Donato, Dei gratia venetiarum et cetera Ducis Illustrissimi, praetureque clarissimus domini Joannis Dominici Ciconia comitis Jadrae eiusque agri dignissimi, Coram spectabile domino Zoylo de Ferra honorando consiliario dicti celeberrimi domini cominitis¹⁹.

The clauses of this particular notarial act, drawn up in Zadar on 2 October 1548, contain valuable information. The procura was initiated by «dominus Joannes de Garzonibus olim comes et capitaneus Tragurij» who appointed «spectabilem virum dominum Joannem Mazzarellum cancellarium Magnificae comunitatis Jadrae» to take care of a specified task. The communal chancellor of Zadar should recover the outstanding sum of 90 ducats and £ 4 «a ser Francisco Patini Brixiensis [...] ut patet chyrographo confessionis debiti dictarum pecuniarum», written in Trogir on 28 June 1548²⁰. The contractual clauses typically end with references to the legal consequences of non-observance by either party (Kolanović & Križman, 1997, pp. 150-160).

At the end of each notarial instrument stood the valediction, which contains the location of stipulation, the names of the two witnesses, and the signature of the public official (p. 670). The document in question was «[a]ctum Jadrae in sala Palatij celeberrimi domini Laurentij Bragadero dignissimi capitanei Jadrae» in the presence of «excellente artium et medicinae doctore domino Federico Zeno medico physico sallariato sive stipendiato Jadrae, et domino Francisco de Mutina»²¹.

Despite the fact that some documents omit certain dates because they were written on the same day and in the presence of the same witnesses as the immediately preceding instrument, the information contained in these procuratorial appointments allows for both qualitative and quantitative analysis. The sample consists of 930 individual notarial acts written by Zadar's notaries between 1 January 1540 and 31 December 1569²². They include the listing of personal names and surnames, trades or occupations, geographical provenance, and indications of citizenship and/or residence status of both contracting parties in relatively uniform terms, allowing for quantitative approaches. With respect to qualitative data, are concerned, about 75 per cent of these *procurae* also include personal information pertaining to a wide variety of issues as diverse as business ties, marriage alliances, or social status. In combination, these data and the governmental sources – the city's statutes and the records by the Venetian administration – have the potential to «bring[ing] the scene closer to life than either set of sources would do on their own» (McKee, 1994, pp. 34-67).

¹⁹ DAZd, SZB, FT box I, fascicle 1, book 1, f. 1r, 2 October 1548. Hence, box, fascicle, and book are omitted.

²⁰ DAZd, SZB, FT I, 1, 1, f. 1r, 2 October 1548.

²¹ DAZd, SZB, FT I, 1, 1, f. 1r, 2 October 1548.

²² These contracts are contained in the protocol books of the 15 notaries and translate to the following numbers per decade 225 individual appointments during the 1540s, 330/1550s, and 375/1560s.

Quantitative approaches to pre-modern exchange in the Venetian maritime state traditionally focused on the analysis of so-called *contralittere* or *bollette*, export/import licences issued by the port authorities in an attempt to enforce Venice's staple rights (Attia, 2008; Kolanović, 1979, pp. 63-150; Raukar, 2000, pp. 49-125). However 'convenient' (Schmitt, 2009, p. 82) this approach might be, it is also highly problematic because of the near total lack of comparative studies which, in turn, only reflects the poor archival situation of these sources²³. Also, by their very nature, export/import licences further our understanding of economic ties, maritime shipping routes, and the individual merchants and sailors involved but have little to say about communication flows.

In order to contribute to this discussion, the author would like to propose large-scale analysis of procuratorial appointments in order to alleviate some of the problems outlined above. The advantage of this particular model is that it could help to overcome the problems of quantitative analysis traditionally associated with the restrictive nature of the export/import licences. Analysis of *contralittere* provides valuable insights into the transactions of the commercial elite but, whatever its shortcomings, the *procura* is a much less exclusive source. While absolutely not the 'ultimate source', these appointments enable a more inclusive approach to pre-modern communication flows, especially in terms of the economic, educational, geographic, occupational, and social diversity of the contracting parties.

In practical terms, the combination of both quantitatively and qualitatively assessed data allows for the tentative classification of the constituent parties' motivations into *economic*, *legal*, and *social* categories. An *economic* assignment refers to any task ranging from commercial endeavours to the recovering of outstanding sums of money, and anything in between. For instance, in the early 1540s «magister Simon Grubissich quondam Antonij de Jadra», a master-caulker, moved to Chioggia. Consequently he appointed 'magistro Martino', a master-cobbler, to sell his house in Zadar²⁴.

Other examples include the recovering of money invested in the Venetian *Monte nuovo* and the administration or sale of property: In the mid-1550s, «magister Joannes Galeacij de Venetijs Marangonus [master-oarsmaker] habitator Jadre» tasked «Franciscum quondam Demetrij Eugenico de Nauplio» (Nafplio) to rent the constituent's house «posita in alma urbe Venetiarum in confinio Sancti Antonij»²⁵. More often, though, Venice's (bad) payment behaviour was at the heart of comparable appointments. Testifying to this – and Venetian credibility –, this motivation

²³ Even if preserved, the requirements of relatively large samples and the selective nature of certain studies contributes to this problematic nature, which is also reflected in the two most recent studies by Schmitt (2001) and Attia, (2008). While the former relies on the (partially problematic) older publications by Kolanović, (1997) and Raukar, (2008), to make a rather different point, the latter analysed approx. 300 export licenses from Trogir for the three years from 1567 to 1569.

²⁴ Which was located «in contrata sive confinio fabrorum, Super Terreno benefitij venerabilij domini presbytri Grisogoni Cedulinj, canonici Jadrensis» (DAZd, SZB, PB I, 1, 8, s.p., 28 May 1541).

²⁵ DAZd, SZB, JM I, 1, 4, f. 83r, 6 January 1556; usually, this particular craft was considered important enough by Venice to restrict its performance to her expatriate citizens. See Ćoralčić, 1999.

transcended all geographical provenances, military ranks, and social boundaries. For instance, in autumn of 1557, 'Joannes Durcich de Aussero' (Osor), a discharged oarsmen, appointed 'Reverendum dominum Georgium Matassouich, Archipresbyterum ruralem diocesis Nonensis' (Nin) to recover the still-outstanding payments for the former's service on the warship commanded by *Magnificum domini Petri Pisani dignissimi supracomitis Birremium* – which had ended more than one and a half years before²⁶. Or take the case of «dona Catherina quondam Magnifici equitis domini Georgij Rhenesi, et uxor Magnifici equitis domini Thomasij Luxi» who, around the same time, appointed «spectabilem dominum Bartholomeum Nigrum» finally to collect her husband's outstanding payment of 25 ducats per annum from the fiscal chamber of Crete²⁷.

The *legal* motivations behind a procuratorial appointment constitute, admittedly, a more technical grouping, including gubernatorial requirements²⁸, conflicting inheritance claims, or more general representation in a court of law, and/or extrajudicial settlements. The last category represents, of course, the most common reason for the appointment of a procurator, ranging from a very limited number of high-profile homicide cases²⁹ to much more mundane causes, mostly related to money. For instance, over the course of ten months «dominus Hieronymus de Gallellis quondam domini Simonis nobilis Jadrensis» thrice appointed «dominum Joannem Franciscum de Dominis nobilem Jadram, et arbensis» (of Rab) to obtain the 15 ducats still missing from his wife's dowry³⁰. Much more common were instruments tasking the appointees with legal representation. Examples include tenants asking for redress of grievances against their landlord³¹ and various unspecified legal proceed-

²⁶ The notarial act reads as follows: «ut dixit desserviens pro Galeotta super birremi per celebrimum dominum Georgium Pisani dignissimi Capitem Birremium ut in licentia desuper facta, data in portu Jadra diei xxx Januarij 1556» (DAZd, SZB, SB I, 1, 2, c. 78v, 15 October 1557).

²⁷ Bartholomaeus was tasked to «ad nomine dicte domine constituentis et pro ea exigendum elleuandum et recuperandum a dicta Camera Cretae omnem et quantacumque pecuniarum summam et quantitatem eudem domini constituenti debitam ratione dictae provisionis suo pro annis decursis» (DAZd, SZB, SB I, 1, 2, c. 74v, 10 September 1557).

²⁸ Zadar's statutes required all girls under the age of 12 and all boys under 14 years to have (at least one) legal guardian; the necessity of tutorship expired once the adolescents of both sexes completed their 20th year (Kolanović & Križman, 1997).

²⁹ E.g., «Spectabilis dominus Georgius ab Aquila nobilis brachiensis» (of Brač) appointed «spectabilem ser Hieronymum de Laurentijs Civem Jadram», to take case of the constituent's agenda in the proceedings against 'Hieronymum de Negroponte' who (allegedly) killed Georgius' next-of-kin, «quondam domini Stephani ab Aquila». Prior to the procuratorial appointment, the suspect had been apprehended by the captain-general in Split. The trial itself was to take place in Šibenik (DAZd, SZB, ND I, 2, 5, f. 62r/ f. 62v, 1 July 1566). Hieronymus de Laurentijs – 'Hierolimo di Lorenzi' – was among those renowned citizens of Zadar named explicitly by former captain Paulo Justiniani (Giustinian) in his report to the Venetian Senate in early 1553 (Ljubić, 1880).

³⁰ The adversaries were the constituent's in-laws, represented by «domino Hieronymo de Nimira alias Polimulcich nobilis arbensis» (DAZd, SZB, ND I, 2, 3, f. 18r, 14 November 1564; ND I, 2, 3, f. 27r, 8 January 1565; ND I, 2, 4, f. 42v / f. 43v, 3 September 1565).

³¹ Usually, labourers sought redress if landlords attempted to levy excess duties, as this example illustrates: «Slade Panoeuich [...] judex possobe ville Sancti Philippi et Jacobi» (Sv Filip i Jakov), representing himself and the other inhabitants of said village, stated that while the rental contract

ings in Zadar, Venice, or elsewhere. Two main elements stand out: first, in most cases the appointed individual(s) originated either from within Zadar's jurisdiction or elsewhere in Dalmatia. Second, once the task involved business in Venice (proper), procuratorial duties were usually assigned to Venetian patricians, Dalmatian nobles, or individuals with judicial knowledge, like attorneys, lawyers, solicitors – of course, not mutually exclusive socio-functional categories. And, as in local dealings, these cases included everything from unspecified legal proceedings in Venice to, though much more rarely, investigations in front of the Venetian Court of Appeals (*Quarantia*)³². In general, the individuals tasked with legal representation, especially in those proceedings taking place in Venice proper, were explicitly referred to as trained experts: advocate or barrister (*advocatus*), attorney (*causidicus*), doctor of both laws (*leges utriusque doctor*), or solicitor (*solicitor*).

The third category, covering *social* motivations, is perhaps most problematic because not only does it include a wide range of diverse appointments, but these regularly transcend the boundaries of the previous two categories. Examples include the tasking of procurators with a high social position to attend the baptism of a Venetian patricians' child, as happened in February of 1558: «[s]pectabilis dominus Franciscus Thomaseus Civis Jadre», one of Zadar's public notaries, needed representatives who would act on his behalf «ad Sacrum baptismatis fontem filiolium vel filiolum nascitutum et nascituram celeberrimi domini Marci Antonij Cornelij [Corner] Patritij Veneti et eius cellberrima uxoris». Understandably, the appointees were of social standing and descent appropriate to the occasion: «Magnificum dominum Michaellem Fuscarno [Foscari] Magnifici domini Hieronymi nobilem Venetiarum» and «dominum Christophorum de Nassis» a renowned nobleman of Zadar³³. Other instances involved the returning of the remains of relatives who had died elsewhere in order to bury them at home. And while these occasions did not arise too often, the posthumous voyage of «quondam nobilis viri domini Theodosij», brother of «strenuus et nobilis vir Jadrensis dominus Simon de

stipulated 12 kvart of corn (1 kvart = ca. 250 litres) as duties to be delivered «in die Sancti Jacobi de mense Julij» (by 29 July) which, according to Slade, will not be possible (Kolanović & Križman, 1997). This issue had first been raised at the beginning of April either because the upcoming harvest would not allow for such large duties or because the landlord had increased the charges unilaterally. Consequently, the plaintiffs appointed 'Excellent dominus Vincentius Merula', a doctor of both laws, to act on their behalf and «deffendere omnes causas dicti [...] communis» (DAZd, SZB, ND I, 2, 3, f. 50v, 2 April 1565).

For the rural organisation of Zadar's hinterlands after 1409, see (Kolanović & Križman, 1997; Mayhew, 2008; O'Connell, 2009; Pederin, 1990; Raukar, Petricioli, Švelec & Peričić, 1987).

³² As was the case when «domini Franciscus, Darius et Baldus filij quondam domini Joannis de Pechiaro, nec non dominu Franciscus de Pechiaro quondam Francisci, Nobiles Jadre» appealed a decision concerning the inheritance of both movable and immovable property «ad favorum dominarum Marchette, Slava, et Gasparine de Pechiaris». The brothers appointed «dominum Camillum de Pechiaro fratrem ipsorum dominorum Francisci, Darij et Baldi» to represent them in the appeal filed «per Excellentem Consilium xxxxi^a» in Venice (DAZd, SZB, JM I, 1, 4, f. 124r, 15 October 1556).

³³ DAZd, SZB, SB I, 1, 2, c. 95r, 2 February 1558.

Begna quondam viri nobilis Christophori», stands out³⁴. A descendant of one of Zadar's aristocratic families, the late Theodosius was «serviens apud Illustrissimum dominum Joannem Baptistam Gastaldum olim capitum Generalis Exercitus Serenissimi Regis Ungarie, In quibus partibus est vita functus». As the heir of his deceased brother, Simon appointed no less a figure than «Nobilem virum dominum Baptistam Besalium de Porto Buffaleta [Portobuffolè], familiarem Celeberrimi domini Paulj Theupuli [Tiepolo] dignissimi oratoris Serenissimi Domini venetj apud Regem Romanorum». Not only should the bodily remains be brought back home – but also whatever amounts of goods and money the late Theodosius possessed³⁵. Instances like these frequently, led to disputes among the living relatives as to how to divide the movable and immovable possessions of the dead, in turn necessitating the appointment of representatives for legal proceedings or extrajudicial settlements³⁶.

3. *Patterns of communication in the Venetian Adriatic.*

Recent years have seen a certain upturn in studies on exchange – in its widest meaning –, resulting in two main concepts. In an attempt to present an encompassing model, Guillaume Saint-Guillaing and Oliver Schmitt identified what they call a *Kommunikationsraum* (sphere of communication). They defined it as an imagined (sub-)entity characterised by the exchange of goods, ideas, and people taking place in an order of magnitude large enough to be identified in comparison with adjacent areas. It combines patterns of migration with older quantitative data derived from *contralittere* and petitions of Dalmatian cities asking for redress of grievances³⁷. Monique O'Connell's approach is different as she places the *Men of Empire* who negotiated, represented, and upheld Venetian rule over parts of mainland Italy and her overseas possessions, at the centre of the argument (O'Connell, 2009, p. 2).

³⁴ Whose *nom de guerre* was 'ut dixit nuncupatim Joannes Croatus' while serving with the Hungarian army (DAZd, SZB, ND I, 2, 1, c. 13r / c. 14r, 8 January 1556).

³⁵ Baptista was appointed «specialiter et expresse ad nominem ipsius domini Constituentis exigendum, percipiendum et recuperandum omnes, et quascumque Sumas, et quantitates denariorum tantum, quas dictus quondam dominus Theodosius eius frater vocatus Joannes Croatus ut supra debebat, et nunc ipse dominus Constituens uti eius frater, et heres habere debet a quibuscumque personis tam publicis tamquam privatis» (DAZd, SZB, ND I, 2, 1, c. 13r / c. 14r, 8 January 1556).

³⁶ Which, of course, did not always end in court as the following example illustrates: In late 1561, a member of Zadar's noble Tetrico family left a patch of land with a quantity of livestock on the island of Iž to his heirs – whose legal right to dispose of this property was promptly challenged by one of his cousins of the related Grisogono family. At the root of this conflict was a marriage contract dating from the late 15th century which caused the feud between next-of-kin some 60 years later and lasted from spring throughout the summer, and into the autumn of 1561. One of the city's notaries, Simon Mazzarellus, filled two entire books with these proceedings which not only include transcripts of the adversaries' lawyers but also copies of the relevant clauses from the statutes as well as all other documentation pertaining to the case. See for example, DAZd, SZB, SM I, 1, books 3 and 4.

³⁷ See note 7.

Tab. 1 *Social and functional origins of contracting parties (1540-1569).*

	Nobles ^a	Clergy ^b	Commoners ^c	Elite citizens ^d	Rest, n/a ^e
Constituents	314 (♀ 83)	124 (30)	231	68 (28)	193
Appointees	360 (♀ 8)	83 (12)	142	196 (81)	149

Sources: see note 9; in all, 930 individual contracts were analysed.

- a) Gives the numbers of contracting parties of noble descent from Venice, Vicenza, Cividale del Friuli, Cres, Krk, Rab, Pag, Zadar, Šibenik, Trogir, Split, Hvar, Kotor, and Hungary; the numbers in brackets marked with ♀ refer to female constituents.
- b) Gives the numbers of contracting parties belonging to the clergy including both individuals and institutions; the numbers in brackets refer to men and women of the cloth of noble descent.
- c) Gives the numbers of contracting parties from the ranks of the commoners.
- d) Gives the numbers of contracting parties according to their job description, including lawyers, chancellors, tax officials, doctors of both laws, notaries, scribes, and medical professionals. On the group definition cf. Grubb, 'Elite citizens', *passim*.
- e) Gives the numbers of contracting parties belonging to none of the groups above.

The approach proposed here is to make use of all of the above, and to introduce quantitative and qualitative analysis of procuratorial appointments in order also to include less top-heavy data. Their inclusion still results in certain biases favouring the upper strata of society, but to a lesser degree than with than data gathered from mercantile endeavours or legal documentation alone (McKee, 1994, p. 35). Table 1, above, clearly illustrates the benefits of this little-used source: Of course, the nobility's share – roughly a third among the constituents and slightly more among the appointees – is much larger than their respective share among Zadar's inhabitants. Around 1550 the city was home to about 6.000 to 6.500 people of whom between 8-10 per cent were of privileged descent (Raukar, Petricioli, Švelec, & Peričić, 1987, pp. 261-262). A second important aspect is associated with the group labelled 'Elite citizens', which describes educated, literate individuals of both noble and non-noble descent. A little surprisingly, its share among the constituents was only about 7 per cent but approximately three times larger among the appointees.

Tab. 2. *Origins and destinations of the contracting parties (1540-1569).*

	Zadar ^a	Dalmatia-Albania ^b	Venice, <i>Terraferma</i> ^c	Italy (excl. Venice) ^d	Rest, n/a ^e
Constituents	744	58	28	13	87
Appointees	534	122	121	26	127
Destinations	205	177	230	38	280

Sources: see note 9; in all, 930 individual contracts were analysed.

a) Gives the numbers of contracting parties and destinations from/to Zadar and its jurisdiction.

b) Gives the numbers from/destined to Dalmatia-Albania, including Bar, Perast, and Kotor, Brač, Cres, Hvar, Korčula, Krk, Omiš, Osor, Pag, Rab, Split, Šibenik, Trogir, and Vis.

c) Gives the numbers from/destined to Venice and the *Terraferma*, including Venice proper, Bergamo, Cividale del Friuli, Crema, Padua, Trecenta, Udine, and Verona.

d) Gives the numbers from/destined to elsewhere in the Apennine peninsula, including Ancona, Bari, Bologna, Ferrara, Vasto, Manfredonia, the Marche region, Parma, Pescara, Pisauro, Pontremoli, Rimini, Rome, Tarvisio, and Vicenza.

Table 2 serves to illustrate two things: first, to establish the geographical provenance of both contracting parties and, second, to pinpoint the destinations of the procuratorial appointees. As regards the places of origin, the numbers above are very clear: four out of five contracting parties came from within Zadar or its jurisdiction. The remaining fifth is divided among the rest of Venice's Adriatic possessions, Istria, the Ionian Islands, Venice and the *Terraferma*, and the rest of Italy. The importance of local affairs is further underlined by the fact that slightly more than 57 per cent of the procurators also originated from within Zadar's jurisdiction. This is mirrored by developments on the (supra-)regional level: the number of appointees from elsewhere in Dalmatia and Albania doubled and the corresponding share of appointees from Venice or the *Terraferma* quadrupled. If compared with the destinations of the procurators, a more nuanced picture of early modern exchange in the Venetian Adriatic emerges. Contrary to the respective numbers of contracting parties who originated in Zadar's jurisdiction, it was Venice proper and her possessions in mainland Italy which attracted the largest number of (identified) procuratorial missions. Zadar and its jurisdiction attracted roughly 22 per cent of all missions, the rest of the dual province of Dalmatia-Albania another 19 per cent. Venice and the *Terraferma*, on the other hand, were the destination of about a quarter (24,7 per cent) of the procuratorial appointees.

If the regional category 'Dalmatia-Albania' is further broken down into individual cities, an even more pronounced picture emerges. Out of these 177 instances,

more than a quarter (49 instances or 27,7 per cent) of all procurators went to Šibenik, slightly more than a tenth each to Pag (18 or 10,2 per cent) and Rab (19 or 10,7 per cent). Areas of elevated importance further to the northwest and southeast of Zadar include Krk and Hvar (17 or 9,6 per cent each) as well as Trogir (14 or 7,9 per cent). With the exception of Venice, the *Terraferma* – which attracted the largest share of those identified, all other cities in the Venetian Adriatic attracted between one and eight appointees only.

4. Conclusion

Despite its many advantages, none of the sources currently in use by historians of the late medieval and early modern Adriatic incorporates large-scale analysis of the *procura*. Neither government records, such as petitions and export/import licences, nor notarial acts alone could provide enough data to reconstruct a full picture of Adriatic communication. The inclusion of the procuratorial appointments could help to alleviate the problems associated with analysing *contralittere* and understanding the negotiated suzerainty of Venice over her overseas dominions. The relative uniformity of the *procurae* and the variety of information usually contained in them can be used for both quantitative and qualitative analysis of pre-modern patterns of communication. As demonstrated above, the rich communal archives along the shores of the Adriatic render possible the investigation of the reasons and rationales behind the procuratorial appointments. In the case of Zadar, between the two 16th-century wars of ‘Holy Leagues’ against the Ottoman Empire, these reasons have been tentatively differentiated into economic, legal, and social motivations.

In addition, the geographical indications contained in about three out of four contracts furthers our understanding of the ‘remarkable geographical fluidity’ so characteristic of Venetian society. Venice was the focal point of her Adriatic possessions, however one cannot overlook the fact that relatively intensive communication links between Zadar and neighbouring centres like Šibenik, Split, and Hvar also existed (Martin & Romano, 2000, p. 21). If the relation between population size and number of procuratorial voyages is taken into account, the intensity of contacts between the cities of central Dalmatia are even more impressive: Šibenik, for instance, was home to 4,000 to 4,500 inhabitants yet managed to attract 49 procuratorial appointees (Malz, 2006, pp. 106-107). In the light of these findings, previous assertions of the existence of ‘areas of sub-regional communication extending from Zadar to Šibenik to Split’ are in need of refinement (Schmitt, 2009, p. 85).

References

- Arbel, B. (1996). Colonie d'oltremare. In A. Tenenti & U. Tucci (Eds.), *Storia di Venezia: Il Rinascimento: Società ed Economia* (Vol. 5., pp. 947-985). Rome: Institute of the Italian Encyclopedia Treccani.
- Attia, S. (2008). *Handel und Wirtschaft der Stadt Trogir nach der Mitte des 16. Jahrhunderts*. Published M.A. thesis, University of Vienna.
- Balard, M. (Ed.), (1998). État et colonisation au Moyen Âge et à la Renaissance. In *Sagas et chroniques du Nord Lyon, 10(20)*. 116-119.
- Balard, M. & Ducellier, A. (Eds.), (1998). Le partage du monde: Échanges et colonisation dans la Méditerranée médiévale. *Bibliothèque de l'école des chartes, 157(1)*, 303-304.
- Borsari, S. (1997). I veneziani delle colonie. In G. Arnaldi, G. Cracco, and A. Tenenti (Eds.), *Storia di Venezia: La formazione dello statzo patrizio* (Vol. 3., pp. 127-158). Rome: Institute of the Italian Encyclopedia Treccani.
- Cessi, R., Giovanni, S. & Knapton, M. (Eds.), (1992). *La Repubblica di Venezia nell'età moderna*. Turin: UTET.
- Čoralčić, L. (1999). The Ragusans in Venice from the 13th to the 18th Century. *Dubrovnik Annals 3*. 13-40.
- Cozzi, G. (1982). *Repubblica di Venezia e Stati Italiani: Politica e Giustizia dal secolo XVI al secolo XVIII*. Turin: Einaudi.
- Cozzi, G. (1997). *Ambiente veneziano, ambiente veneto: Saggi su politica, società, cultura nella Repubblica di Venezia in età moderna* (p. 292). Venice: Marsilio.
- Cracco, G. (1961). "Relinquere laicis e que laicorum sunt": Un intervento di Eugenio IV contro i preti-notai di Venezia. *Bollettino dell'Istituto de Storia della Società e dello Stato Veneziano, 3*. 179-189.
- Crouzet-Pavan, É. (2002). *Venice Triumphant: The Horizons of a Myth*. Baltimore, MD: John Hopkins University Press.
- De Benvenuti, A. (1944). *Storia di Zara dal 1409 al 1797*. Milan: Bocca.
- Diedo, A. (1553). Relatione del sindacato di Dalmatia et Albania. In *Commissiones et relationes Venete, 3*. 18-19.
- Doumerc, B. (2001). L'Adriatique du XIII^e-XVII^e siècle. In P. Cabanes (Ed.), *Histoire de l'Adriatique* (pp. 203-311). Paris: Seuil.
- Engel, P. (2001). *The Realm of St Stephen: A History of Medieval Hungary, 895-1526*. London: I.B.Tauris.
- Engel, P., Kristó, G. & Kubinyi, A. (2008). *Histoire de la Hongrie médiévale: Des Angevins aux Habsbourgs*. Rennes: Presses Universitaires de Rennes.
- Eufe, R. (2006). *Sta Lengua Ha Un Privilegio Tanto Grando: Status Und Gebrauch Des Venezianischen in Der Republik Venedig*. Frankfurt: Förlag Peter Lang GmbH, Internationaler Verlag Der W.
- Georgopoulou, M. (2001). *Venice's Mediterranean Colonies: Architecture and Urbanism*. Cambridge: Cambridge University Press.
- Graciotti, S. (1997). Plurilinguismo letterario e pluriculturalismo nella Ragusa antica (un modello per la futura Europa?). *Atti e Memorie della Società Dalmata di Storia Patria, 20(9)*. 1-16.
- Grubb, J. S. (2002). Elite Citizens. In J.J Martin & D. Romano, *Venice Reconsidered: The History and Civilization of an Italian City-State* (pp. 339-364). Baltimore, MA: JHU Press.
- Guzzetti, L. (2002). *Venezianische Vermächtnisse: Die soziale und wirtschaftliche Situation von Frauen im Spiegel spätmittelalterlicher Testamente*. Stuttgart-Weimar: J. B Metzler.
- Ivetic, E. (2000). *Oltremare: L'Istria nell'ultimo dominio veneto*. Venice: Istituto Veneto di Scienze.
- Ivetic, E. (2002). Storiografie nazionali e interpretazioni della Dalmazia medievale. In N. Fiorentin (Ed.), *Venezia e la Dalmazia anno mille: Secoli di vicende comuni* (pp. 95-133). Treviso: Canova.
- Ivetic, E. (2005). Dalmazia e Slavi negli studi di Roberto Cessi. *Archivio Veneto, 164*. 125-144.
- Jacoby, D. (1973). The Encounters of Two Societies: Western Conquerors and Byzantines in the Peloponnese after the Fourth Crusade. *American Historical Review, 78*. 873-906.
- Jacoby, D. (1989). Social Evolution in Latin Greece. In N. Zacour and H. Hazard (Eds.), *A History of the Crusades: The Impact of the Crusades on Europe* (Vol. 4., pp. 177-222) Madison, WI: University of Wisconsin Press.

- Jacoby, D. (1998). La colonisation militaire vénétienne de la Crète au XIII^e siècle. In M. Balard and A. Ducellier (Eds.), *Bibliothèque de l'école des chartes: Le partage du monde: Échanges et colonisation dans la Méditerranée médiévale, 157(1)*, 297-314.
- Jungwirth, J. (2006). Procurator. In T. Olechowski & R. Gamauf, (Eds.), *Studienwörterbuch Rechtsgeschichte und Römisches Recht* (p. 375). Vienna: MANZ.
- Karapidakis, N., Kitromilides, P. & Papadia-Lala, A. (2001). In G. Ortalli and C. Maltezos (Eds.), *Italia-Grecia: Temi e storiografie a confronto*. Venice: Hellenic Institute of Byzantine and Post-studies of Venice.
- Kolanović, J. (1979). 'Izvori za povijest trgovine i pomorstva srednjovjekovnih dalmatinskih gradova s osobitim osvrtom na Šibenik (*contralittere*). *Adriatica maritima*, 3. 63-150.
- Kolanović, J. (Ed.), (2006-2007). *Pregled arhivskim fondova i zbirki republike Hrvatske*. Zagreb: National Archives in Varazdin.
- Kolanović, J. & Krizman, M. (Eds.), (1997). *Zadarski statut sa svim reformacijama odnosno novim uredbama donesenima do godine 1563*. Zadar: Matica.
- Krekić, B. (1996). Venezia e l'Adriatico. In G. Arnaldi, G. Cracco, and A. Tenenti (Eds.), *Storia di Venezia: La formazione dello statzo patrizio* (Vol. 3., pp. 51-82, 73-82). Rome: Institute of the Italian Encyclopedia Treccani.
- Krekić, B. (1997). On the Latino-Slavic Symbiosis in Late Medieval and Renaissance Dalmatia and Dubrovnik. In B. Krekić (Ed.), *Dubrovnik: A Mediterranean Urban Society, 1300-1600* (pp. 312-332). Aldershot: Routledge.
- Lane, C. F. (1973). *Venice: A Maritime Republic*. Baltimore, MD: John Hopkins University Press.
- Ljubić, S. (Ed.), (1880). *Commissiones et Relationes Venetae: Tomus III, Annorum 1553-1557*. Zagreb: Sumptibus Academiae Scientiarum et Artium.
- Malz, A. (2006). Frühneuzeitliche Modernisierung als Sackgasse: Die dalmatinische Städtewelt vom 15. bis zum 18. Jahrhundert. In C. Goehrke (Ed.), *Städte im östlichen Europa: Zur Problematik von Modernisierung und Raum vom Spätmittelalter bis zum 20 Jahrhundert* (pp. 103-133). Zurich, Switzerland: Chronos Verlag.
- Martin, J. & Romano, D. (Eds.), (2000). *Venice Reconsidered: The History and Civilization of an Italian City-State, 1297-1797*. Baltimore, MD: John Hopkins University Press.
- Mayhew, T. (2008). *Dalmatia Between Ottoman and Venetian Rule: Contado Di Zara, 1645-1718*. Rome: Viella.
- McKee, S. (1994). Women under Venetian Colonial Rule in the Early Renaissance: Observations on Their Economic Activities. *Renaissance Quarterly* 51(1). 34-67.
- McKee, S. (2000). *Uncommon Dominion: Venetian Crete and the Myth of Ethnic Purity*. Philadelphia, PA: University of Pennsylvania Press.
- Michael M. (2009). Le varietà italiane sulle coste dell'Adriatico orientale. In G. Ortalli and O. Schmitt (Eds.), *Balcani occidentali, Adriatico e Venezia fra XIII e XVIII secolo / Der westliche Balkan, der Adriaraum und Venedig, 13.-18. Jahrhundert* (pp. 199-237). Vienna: Oster-Reichische Akademie der Wissenschaften.
- Novak, G. (1944). *Prošlost Dalmacije* [History of Dalmatia]. Zagreb, Croatia: Slobodna Dalmacija i Marjan Tisak.
- O'Connel, M. (2009). *Men of Empire: Power and Negotiation in Venice's Maritime State*. Baltimore, MD: John Hopkins University Press.
- Ortalli, G. (2009). Beyond the Coast: Venice and the Western Balkans: The Origins of a long Relationship. In Gh. Ortalli and O. Schmitt (Eds.), *Balcani occidentali, Adriatico e Venezia fra XIII e XVIII secolo / Der westliche Balkan, der Adriaraum und Venedig (13.-18. Jahrhundert)* (pp. 9-25). Vienna, Austria: Oster-Reichische Akademie der Wissenschaften.
- Pedani F. M. (1996). *Veneta Auctoritate Notarius: Storia del Notariato Veneziano, 1514-1797*. Milan: Giuffrè.
- Pederin, I. (1990). Mletačka uprava, privreda i politika u Dalmaciji (1409-1797). *Journal of the Institute of Croatian History*, 24(1). 21.
- Pederin, I. (2001). Il mito di Venezia nella storiografia e letteratura Croata secoli XV-XIX. In S. Graciotti (Ed.), *Mito e antimito di Venezia nel bacino adriatico* (pp. 41-63). Rome: Calamus.

- Praga, G. (1954). *Storia di Dalmazia*. Milan: CEDAM.
- Raukar, T. (2000). 'Jadransko gospodarski sustavi: Split 1475.-1500. godine [Adriatic maritime commerce: Split]. *Radovi Hrvatska Akademije Znanosti i Umjetnosti*, 38. 49-125.
- Raukar, T. (2008). Croatia within Europe. In I. Supićić (Ed.), *Croatia and Europe: Croatia in the Late Middle Ages and the Renaissance: A Cultural Survey* (pp. 7-38). London: Philip Wilson Publishers.
- Raukar, T., Petricioli, I., Švelec, F. & Peričić, Š. (1987). *Zadar pod mletačkom upravom, 1409-1797. The Past of Zadar*. Zadar: Zadar Faculty of Arts.
- Rubinstein, N. (1973). Italian Reactions to *Terraferma* expansion in the 15th century. In J. Hale (Ed.), *Renaissance Venice* (pp. 197-217). Venice: Faber.
- Saint-Guillain, G. & Oliver J. S. (2005). Die Ägäis als Kommunikationsraum im Späten Mittelalter. *Saeculum*, 56(2). 215-225.
- Šanjek, F. The Church and Christianity. in S, Ivan. *Croatia in the Late Middle Ages and the Renaissance* (Vol. 2., pp. 227-258). London: Philip Wilson.
- Schmitt, O.J. (2001). Das venezianische Albanien, 1392-1479. *Southeast European works*, 110. Munich: De Gruyter Oldenbourg.
- Schmitt, O.J. (2009). Das venezianische Südosteuropa als Kommunikationsraum (ca. 1400-ca.1600). In Gh. Ortalli and O. Schmitt (Eds.), *Balcani occidentali, Adriatico e Venezia fra XIII e XVIII secolo / Der westliche Balkan, der Adriaraum und Venedig (13.-18. Jahrhundert)* (pp. 77-101). Vienna, Austria: Oster-Reichische Akademie der Wissenschaften.
- Šimunković, L. (1997). La politica linguistica della Serenissima verso i possedimenti "di là da mar": Il caso della Dalmazia. In S. Gracioti (Ed.), *Mito e antimito di Venezia* (pp. 95-104). Rome: The Calamus.
- Viggiano, A. (1994). Note sull'amministrazione veneziana in Istria nel secolo XV. *Acta Histriae*, 3. 5-20.

Archives

- DAZd. Croatian State Archive in Zadar.
- SZB. Manuscripts of Notaries from Zadar.

The Construction of a Professional Minority. 'Istrian Pilots' in Early Modern Venice (15th-18th Centuries)

ALESSANDRO BUONO

*My wind cooling my broth
Would blow me to an ague when I thought
What harm a wind too great might do at sea.
I should not see the sandy hour-glass run
But I should think of shallows and of flats,
And see my wealthy Andrew [dock'd] in sand,
Vailing her high top lower than her ribs
To kiss her burial. Should I go to church
And see the holy edifice of stone,
And not bethink me straight of dangerous rocks,
Which touching but my gentle vessel's side
Would scatter all her spices on the stream
Enrobe the roaring waters with my silks,
And in a word, but even now worth this,
And now worth nothing? Shall I have the thought
To think on this, and shall I lack the thought
That such a thing bechanc'd would make me sad?
But tell not me; I know Antonio
Is sad to think upon his merchandise.*

William Shakespeare
The Merchant of Venice, act 1. sc. i. ll. 23–40.

1. Introduction

The aim of this article is to report the first findings of a research regarding the professional brotherhood of the so-called *pedotti d'Istria*, i.e. Istrian ship pilots, a selected group of seamen, that, around the middle of the fifteenth century and until the fall of the *Most Serene Republic*, were awarded the legal monopoly of piloting ships between the Istrian peninsula, located at the head of the Adriatic Sea in front of the Venetian lagoon, and the city of Venice. Vessels sailing towards Venice, in order to safely reach the Venetian lagoon, were obliged by law to embark experienced pilots in the two Istrian ports of Rovigno and Parenzo (Rovinj and Poreč, nowadays in Croatia). One of the most interesting characteristics of *pedotti's* brotherhood, though, was that whilst they were forced to stay in the above mentioned ports, they had the obligation to keep their families in Venice.

This obligation, which made them a crucial group of border-crossers, leads to some questions about the formation of this sort of "professional minority" and about its role as a link between the two sides of the Adriatic Sea, "ferrying" not

only ships and goods, but creating networks. As we shall see in the following pages, between the second half of the fifteenth and the first half of the sixteenth century the construction of what we might call a “maritime minority” involved seamen proceeding from the whole Venice Sea Dominions (*Stato da Mar*), who established their residence in Venice and merged in a handful of kinships, that would monopolize the profession of pilot since the fall of the Republic. In this process, significantly, the “national” or “ethnic” origin was not a decisive factor: permanent residence in Venice was cogent.

Finally, I will also suggest an interpretation of this corporate body as a mean of defending a local and community resource: pursuing a profession in the old regime, according to recent historiography (Cerutti, 2012), was considered not only a matter of personal skills and territorial know-how (knowledge of sea routes and Adriatic Sea morphology, cognition about the characteristics of Venice lagoon seabed, et cetera), but as a resource of a community. Only community-members, in other words, owned the right to access and exploit job opportunities, and only their corporate body could legitimately confer this right.

2. *The profession of pedotti d’Istria*

The professional activity of pilots certainly arose in the medieval era, and originated by the necessity of navigation itself (Parenzo, 1897, pp. 37-56; Sambo, 1991, pp. 837-843)¹. The organization of pilots in a corporate body, instead, is rather late compared to other guilds². The erection of the “School” of *pedotti*, in fact, occurred only in the middle of the fifteenth century, when, in 1450, the Senate (or *Consiglio dei Pregadi*) approved the charter of the brotherhood, the so-called “*Mariegola*”³.

However, unlike other “Arts corporations”, Istrian Pilots were not strictly a “guild” but a “brotherhood”⁴, which means that they were less autonomous and,

¹ There are only a few hints, in modern historiography, about the history of *pedotti d’Istria*: the article of Aldo Parenzo (1896) aimed to reconstruct the late eighteenth century reform of the entrance examination and in addition, only half a dozen pages are dedicated to them in Alessandra Sambo’s *Il lavoro portuale* (1991).

² The arts guilds in Venice and the so-called “Schools”, established especially from thirteenth century, had a somewhat different development from those of other Italian cities. Initially born as confraternities, for devotional and charitable purposes, only at a later time began to regulate the professional activities of its members. See Lane, 1973. On the specific characteristics of the corporations in Venice see Mackenney, 1987; Caravale, 1997.

³ ASVE, Ufficiali al Cattaver, b. 3, reg. 5, *Concession de la Schuola, e Matrichula de li Pedotti*, 2 September 1450.

⁴ «Significantly, the guilds for which there is the earliest evidence did not represent the most important professions or occupations»: for example, there was no guild for «merchants engaged in foreign trade’ or guilds ‘representing judges, lawyers, and notaries». «There was also no guild of mariners, neither of masters and mates, nor of ordinary seamen, at least no until a very late date ... The seamen lacked a guild for the same reasons general merchants did; they were too numerous». «They were, to be sure, a number of religious fraternities honouring Saint Nicholas, the patron saint

instead of being under the ordinary jurisdiction of the so-called “Executioners” (*Giustizieri*), they were subject to a specific Venetian magistracy, the *Ufficiali al Cattaver* (Lane, 1973, p. 106). This institution was already established by the Great Council at the end of the thirteenth century (in 1280) and soon merged with the Office of Smuggling (in 1292), with the very intent to control state privileges and properties, and prevent smuggling (Caravale, 1997, pp. 336-337).

The year 1440 is constantly remembered as the «beginning of the profession of Istrian Pilots» in the documents of the following centuries. However, even before this, these pilots should have been associated at least for economic purposes and mutual aid. In 1440, indeed, in responding to a *pedotti*'s plea, asking the *Consiglio dei Pregadi* among other things to punish pilots who did not respected the orders to reside in Istria or ship's masters embarking Istrian mariners instead of them, the Senate ordered to devolve the third part of all the pecuniary sanctions to ‘all pilots’⁵. A common treasury, hence, already existed.

Furthermore, at least in the fifteenth century the institution of *Cattaver* had the duty to enrol in a special book those pilots who had the privilege to perform the profession. Until mid-sixteenth century they were known in official records as ‘Pedotti de Venetia’ or ‘Pedotte Castelli’ (i.e. Venetian pilots, or pilots of the *Sestriere Castello*)⁶. Moreover, at least since 1440 the *Cattaver*, together with the *Savi agli Ordini*⁷, were entitled to biannually control *pedotti*'s professional skills, theoretical and practical, through an exam aimed at testifying that they fulfilled their tasks and had abstained from committing contrabands (Rossi, 1991, pp. 668-694)⁸.

If, then, the professional group of this specific sort of pilots existed in Venice before the mid-fifteenth century, as we have already said, the *pedotti*'s ‘School of the Holy Cross’ was officially established only in 1449–1450⁹, in the Basilica of St

of seamen, ... but the oath required of seamen was prescribed by the maritime code of 1255 [the Ranieri Zeno's code], not by any guild statutes» (Lane, 1973).

⁵ «De la ... pena pecuniaria el terzo ... sia de tutti li altri Pedotti», (ASVE, Ufficiali al Cattaver, b. 3, reg. 5, *In Pregadi 1440. A di 27 luglio. Cercha el star deli Pedotti a Parenzo, e a Rovigno, et el star de la Prova con i Sig. Cattaveri, et Savij di ordeni do volte alano [sic], sotto pena, uts. in capo*, 27 July 1440).

⁶ ASVE, Ufficiali al Cattaver, b. 3, reg. 5, *Concession de la Schuola, e Matrichula de li Pedotti*, 2 September 1450.

⁷ At the beginnings of the fifteenth century the five *Savi agli Ordini* (“Orders” were the maritime regulations) were responsible to give preliminary advice to the Senate in all affairs concerning the administration of maritime domains and the fleet. However, they progressively lost any decision-making power, and became only a stage in the governmental training of young aristocrats.

⁸ To ensure that all *pedotti* carry out their job properly, the *Savi agli Ordini* and *Cattaver* are required to congregate twice a year, to get information on *pedotti* and to approve, or disapprove those who for its own negligence, or ignorance, caused accidents, or have smuggled. See ASVE, Ufficiali al Cattaver, b. 3, reg. 5, 27 July 1440.

⁹ For the brotherhood's charter see ASVE, Ufficiali al Cattaver, b. 3, reg. 5, cf. 14 January 1448 *more veneto* (i.e. 1449, because in the “venetian style” calendar the new year begun on the first day of March) and 2 December 1450.

Peter of Castello which in 1451 became the seat of the new Patriarch of Venice¹⁰. In 1450, then, the *Consiglio dei Pregadi* ratified the 15 chapters of the *pedotti's Mariogola*, the charter which settled the basic rules of the brotherhood, partially reformed in 1491 (Cassandro, 1981, pp. 281-300)¹¹.

The number of pilots forming the brotherhood varied through the decades: one of the first congregations of the “School”, held in Istria in 1458, had only thirteen participants¹². These would increase over the following centuries, but would never go beyond a few dozen people: in 1752, when the profession contemplated an internal structure based on the length of service, there were thirty Istrian Pilots.

The structure of the profession became stable in the mid–sixteenth century, when a young boy, of the minimum age of ten years, could start as an apprentice in the service of a senior pilot. After seven years of service, after an examination carried out in front of the *Ufficiali al Cattaver* and the *Savi agli Ordini*, he could access the rank of “small pilot” (*pedotta piccolo*), and after another five years of work, with a minimum age of 22 years, he could become “great pilot” (*pedotta grande*). Finally, after another twenty-two years of work he could retire (*pedotta giubilato*), enjoying all the privileges of the corporation (Sambo, 1991, p. 838). Their small number made necessary to appoint some ‘pedotti di rispetto’ (or reserve pilots), both in the category of great and small¹³.

The distinction between great and small pilots refers to the deadweight of vessels that they can control¹⁴: small pilots could control only vessels of less than one

¹⁰ «During the Schism of the West, Venice always adhered to the Roman obedience. [In 1451], upon the death of Domenico Michel, Patriarch of Grado, Nicholas V suppressed the patriarchate and the Bishopric of Castello, incorporating them both in the new Patriarchate of Venice (Bull, *Regis aeterni*), thus Venice succeeded to the whole metropolitan jurisdiction of Grado, including the sees of Dalmatia. The election of the patriarch belonged to the Senate, and this practice sometimes led to differences between the republic and the Holy See» (Benigni, 1912).

¹¹ The *Capitolo* (assembly) of the profession periodically produced new *capitolazioni* (amendments to the School’s Charter) submitted for the approval to the *Cattaveri*, since the promulgation of the *Codice per la Veneta mercantile Marina* in 1786 (ASVE, Ufficiali al Cattaver, b. 3, reg. 5, 1491. *Adi 15 settembre. Che alcun non possi esser pedotta sel non sarà sta’ fiol de pedotta over fante, sotto pena*, 15 September 1491). See also Cassandro, 1981.

¹² ASVE, Ufficiali al Cattaver, b. 3, reg. 5, 1458. *Adi 26. mazo. Cercha la samination, ala prova, che sia examinati. 6. pedotti da botte 100 in zoso, e quelli sara trovati sufficienti, siano de rispetto. de i grandi i qual se possino acodar con ogni fusto non se trovando li de i pedotti grandi*, 26 March 1458.

¹³ «Reserve pilots» were mentioned for the first time in 1458, when, due to the scarcity of pilots, only a dozen, compared to the ships waiting for them in Istria, the *Cattaver* dictated the creation of the figure of the *pedotta di rispetto* (ASVE, Ufficiali al Cattaver, b. 3, reg. 5, 26 March 1458).

¹⁴ The internal partition between the big and the small pilots, according to the deadweight of vessels that they were allowed to navigate, was already established around the mid–fifteenth century gradually becoming more severely prescribed. However, a small pilot was often allowed to conduct a big vessel in absence of *pedotti grandi*. See ASVE, Ufficiali al Cattaver, b. 3, reg. 5, *Cercha la portata della nave, et navilij che portano stara 1000 de formento, se intenda esser de botte 100, et se porteranno oltra ditta quantità, per cadauno centenaro de stara se intenda botte 10*, undated but likely 1449 or 1450.

hundred Venetian barrels (more or less, sixty–four tons)¹⁵ (Martini, 1883, p. 818). Just to compare: «Columbus’s *Santa Maria* is estimated at 100 tons» while ordinary ships in the Mediterranean could be estimated at two hundred tons and «500 tons meant a very big ship any time before the nineteenth century»¹⁶ even in the oceans (Hocquet, 1991, p. 482; Lane, 1973, p. 46).

Also piloting tariffs, obviously, were established on the basis of ships’ deadweight and varied through the centuries: at mid–fifteenth century, for example, the cost of the crossing was three ducats¹⁷ for a voyage of about ninety miles, which lasted a day and a night (Lane, 1973, p. 58), while at the end of the seventeenth century ships embarking Istrian pilots were required to pay ten ducats¹⁸.

As with all corporations, the brotherhood task was to assist the members in case of illness, temporary disability or old age. In addition, the corporation took care to provide dowry for the orphaned daughters of members, and to pay for the burial of needy “brothers”¹⁹. Another special privilege, was the use of electing old pilots as guardians of Venice’s castles, the two fortresses of San Nicolò and Sant’Andrea (*Doi Castelli*), positioned at the two sides of the Lido’s harbour entrance (Concina 1995; Morachiello, 1991b). This was certainly a form of retirement reward, but also a demonstration of the bond existing between the profession of pilot and the acquisition of a specific knowledge crucial for Venice’s defensive system²⁰. In addition to the presence of *pedotti* in the castles, in fact, among them were chosen by the *Cattaver* the two Admirals of the ports of Lido and Malamocco, two important authorities entitled to supervise all operations of enter and exit the lagoon. The Admirals were claimed to guarantee the twofold objective of attracting and ensuring the safety of merchant vessels in the hazardous waters of lagoon’s en-

¹⁵ In the early modern centuries barrel a Venetian weighed about six hundred forty (640) kilograms or about seven hundred fifty (750) litres capacity.

¹⁶ The major vessels in the sixteenth century Venice had a tonnage of between 500 and 1.200 venetian barrels.

¹⁷ In 1512 was established a complete transportation fare table, used as benchmark still in the seventeenth century, when the previous date was cited as the «time of the construction of the professional fares» (ASVE, Ufficiali al Cattaver, b. 3, reg. 5, cf. 6 September 1452 and 18 July 1636).

¹⁸ At the end of the seventeenth century, the Republic was inundated with requests for exemptions and was forced (after having repeatedly refused to grant privileges to “Greek” captains of *Tar-tane* and *Saicche*) to concede English, Flemish and in the end French vessels to not embark the *pedotta* in Istria. It was a privilege aimed to facilitate the trade («facilitar il comercio») in a harsh moment, leaving to the ‘good generosity’ of foreign captains to autonomously decide whether or not to embark the Istrian pilot and consequently pay his reward. See ASVE, Ufficiali al Cattaver, b. 3, reg. 5, 14 April 1678, 31 August 1678, 10 June 1679 and 18 December 1686.

¹⁹ See *capitolazioni* of 1513 and 1551 (ASVE, Ufficiali al Cattaver, b. 3, reg. 5, 6 September 1513 and 11 April 1551).

²⁰ Alessandra Sambo (1991), highlights the Senate order given to the magistracy of *Patroni all’Arsenal* to confer the position of castles guardians to retired *pedotti*, but does not stress the connection between the profession of pilot and Venice’s defensive system. See ASVE, Ufficiali al Cattaver, b. 3, reg. 5, 15 April 1519; 21 September 1530 and ASVE, Senato Mar, reg. 22, 8 October 1530.

trances, and defending the city from invasions such as the recent Genoese during the War of Chioggia (Crouzet–Pavan, 1988, pp. 625-652)²¹.

3. *Environment, defense and iurisdictio.*

We may argue that the ratification of the corporate body of *pedotti* in the middle of the fifteenth century, had, among others, an environmental reason. This century represented a crucial point (Bevilacqua, 1995; Ciriaco, 1998, pp. 613-650; Dorigo, 1995, pp. 137-191; Zannini, 2012, pp. 100-113; Zucchetta, 2000), characterized by a marine regression that had lowered the sea level by more than one meter, and precisely during this decade Venetian authorities began to conceive a set of interventions to preserve the navigability of the lagoon²². Cane thicket progressed and ebb tides made even more complicated the navigation in the lagoon: the level of the water lowered so much that the *Canal Grande* was reduced to a small canal whose embankment was occupied by vegetable gardens. In other words, the authorities were frightened by the very prospect of the drying out of the lagoon²³.

It is not therefore surprising that one of the most important duty of the *pedotti* was to periodically plumb the depths of the lagoon, and of its three main entrances, the canals («fosse») of Lido, Malamocco and Chioggia: every *pedotta*, in fact, had to present to the *Ufficiali al Cattaver* an official proof of having been «looking for water» («cerchar l'acqua») certified by the two Admirals of the ports of Lido and Malamocco. In particular, the latter became increasingly important during the first half of the sixteenth century, when the process of burial, caused especially by the sediments carried by rivers flows, severely reduced the navigability of the Lido's canal (Calabi, 1991, pp. 767-768). Therefore, the Senate periodically ordered the *pedotti* to get acquainted with the routes of Malamocco, now the principal port of the lagoon, and the *Ufficiali al Cattaver* and *Savi agli Ordini* to monitor that they

²¹ The tower of San Nicolò, considered 'ancient' and in late medieval times, was primarily a watchtower. At the beginnings of the fourteenth century the *Maggior Consiglio* resolved to use it as lighthouse. Only after the Genoese occupation of Chioggia, during the War 1378–1381, Venetian authorities began to discuss the opportunity of fortify the ports of Lido and, in the sixteenth century, Malamocco. See Morachiello, 1991b and Concina, 1995. On the War of Chioggia see Lane, 1973; Epstein, 1996; Dotson, 2003.

²² «Gênes crée à la fin du XIIIe siècle, les “Salvatores portus et moduli”, Venise ne dispose pas d'un corps d'officier responsables directement du port. La plus ancienne magistrature en charge de l'organisme urbain date de 1224. Instituée “pro ripis, pro viis publicis et pro viis de canali”, elle donne rapidement naissance à des fonctions distinctes qui se partagent les domaines de la terre et de l'eau. Mais le port n'apparaît dans aucune des formulations qui ponctuent les fluctuations des pouvoirs confiés à ces officiers. ... Les dragages du bassin de S. Marco deviennent, au XVe siècle, plus nombreux, les officiers du *Piovego* en assument la conduite. Quand, dans la seconde moitié de ce siècle, les Sages sur les Eaux fonctionnent avec une régularité accrue, ils assument en matière aquatique, lagunaire ou citadine, une juridiction générale» (Crouzet-Pavan, 1988).

²³ For the environmental crisis see especially Dorigo, 1995.

had ‘diligently’ accomplished their duty to biannually probe the deepness not only of San Nicolò, but also of Malamocco and Chioggia²⁴.

At the same time, between the first travel of a public ship through Malamocco at the beginning of the 1490s²⁵ and the first half of the sixteenth century, the charge of Admiral of Malamocco (equivalent of that of Lido) was progressively institutionalized. This charge seems to have been initially granted to the Berengo family (Antonio and his sons) as reward to their ‘intelligent and industrious activity’ of ‘measuring the deepness, width and length’ of that ‘unusual port’ and ‘against the advice and opinion of the most pilots and men of Saint Nicolas’²⁶.

In other words, the *pedotti* case could be a meaningful example of how Venice’s land and resource use policy was able to combine a strong governmental control and an ability to listen and value practical knowledge, like the one of mariners and, in our case, experienced pilots, in order to transform the lagoon according to the adage ‘great lagoon makes great harbour’ (Zannini, 2012, p. 111)²⁷.

As a matter of fact, one of the most important reasons for laws constraining vessels to embark an approved pilot in Istria was the prevention of ship sinking²⁸. The conjuncture of the mid fifteenth century, then, may have only worsened what is one of the characteristics of navigation in the Venetian lagoon and in the high Adriatic sea: the constantly shifting conditions of this sandy and shallow seabed made the service of expert pilots essential to ensure navigation.

Studies devoted to reconstruct the history of navigation in the Mediterranean Sea demonstrated that during the early modern era captains did not practice celestial navigation, but continued to use coastal navigation (*cabotaggio*) using orographic reference points (Tucci, 1991, pp. 527-559). It was common, then, to embark alongside the main captain others local pilots familiar with specific coastal areas (Hocquet, 1991, p. 490).

²⁴ The *Pregadi* repeatedly ordered the *pedotti* to plumb the depths of Malamocco’s waters, e.g. in 1520, 1526, 1533, 1542. See ASVE, Ufficiali al Cattaver, b. 3, reg. 5, c. 38v, *Condanna ai pedotti che siano trovati ubriachi; obbligo per i Pedotti di andare a scandagliare almeno 2 volte all’anno i porti di Malamocco e Chioggia*, 19 February 152. Cf. also, Ivi, c. 33r, *Crida fatta, che nisun pedota non possa Scandaiair l’acqua salvo lo armiraglio overo a chi lui desse licentia*, 27 september 1520; Ivi, ‘Capitoli n. 9 presi in diverse matterie, cerca l’arte del pedottar ut in eis.’, 5 March 1533; ‘Capitoli n. 8 presi in diverse matterie, cerca l’arte del pedottar ut in eis.’, 22 March 1542).

²⁵ The first ship of the Republic crossed Malamocco’s canal just before the 1493. See Morachiello, 1991a.

²⁶ ASVE, Ufficiali al Cattaver, b. 3, reg. 5, 28 August 1492.

²⁷ Andrea Zannini criticises (Zannini, 2012), among others, Piero Bevilacqua’s (*Venezia e le acque*) interpretation of Venetian politics in terms of “environmental safeguard”. On the relationship between technical knowledge and the primacy of the political leadership in the environmental policy of the *Serenissima* see also Caniato, 1995 and Rinaldo, 2009.

²⁸ Documents of the second half of the fifteenth century are full of references to shipwrecks, and underlined that the crossing, dangerous per se, had become even worse «for having the port become awful». See for example ASVE, Ufficiali al Cattaver, b. 3, reg. 5, 1491. *Adi 15 settembre. Che algun non possi esser pedotta sel non sarà sta’ fiol de pedotta over fante, sotto pena*, 15 September 1491.

Within the Adriatic sea, in particular, captains showed greater preference for sailing along Dalmatian coasts (the route called *sopravento*, i.e. windward)²⁹, that, in contrast to the Italian's, «offered a vast choice of berths and channels, which prevented the formation of large waves and offered refuge to ships»³⁰ when the strong north–eastern winds blew (such as the *Bora*), in addition to a vast number of bays, islands and terrestrial points of reference that could foster the orientation (Pagratis, 2006, p. 848). Apart from these natural advantages, there were severe laws constraining the ships of the Venetians and the subjects of the Serenissima to follow the eastern route, in order to avoid the competition of Marche's and Abruzzo's fairs, like Senigallia and Lanciano ones, and the competitor port of Ancona. One of these restrictions was precisely the order to embark *pedotti d'Istria* in the two ports of Rovigno and Parenzo, the last docking places on the route to Venice.

We have already highlighted the military issues that led the *Pregadi's* Council to strictly submit the *pedotti* 'School of the Holy Cross' under the closer control of a specific Venetian court, and not to grant them autonomous jurisdiction. There are at least other two aspects of particular interest that can be mentioned, concerning jurisdictional and ceremonial issues.

From the specific point of view of early modern jurisdictional grammar of power³¹, this brotherhood should have performed a crucial role: the corporation, as far as I understand, is far more than only a mean to control and prevent smuggling. In the eyes of the *Most Serene* Republic of Venice the effort made to place an approved pilot on every ship sailing in the Northern part of the Adriatic was a jurisdictional act, because commerce indeed is an act of *iurisdiction*, that creates, constructs and identifies spaces of contested sovereignty³². This, I believe, is the reason behind the constant injunction issued by Venetian authorities imposing these pilots to actively participate in the Ascension feast³³, «the centrepiece of a great communal ritual that, more than anything else, pronounced the imperial designs of

²⁹ See, for example, the evidences given by Gerassimos D. Pagratis (2006) in his study devoted to reconstruct an history of incidents of merchant shipping in the Adriatic and Ionian Sea during the seventeenth and eighteenth century.

³⁰ See also Colak, 1969, 1972; Tenenti, 1979, 1980.

³¹ I refer, primarily, to Italian and Iberian legal historians, scholars like Paolo Grossi, António Manuel Hespanha, Bartolomé Clavero and Pietro Costa. See for example Costa, 1969 and to more recent historiography conscious of the relevance of actions and practice in creating rights and power like Torre, 2011. See also Bordone, Guglielmotti, Lombardini & Torre, 2007.

³² See Torre, 2011.

³³ The chapter nine of the School *Mariegola* stated that the profession chief (the *gastaldo*) had to tow the Patriarch toward the island of St. Helena and the port of St. Nicholas while «the rest of *pedotti* have to pilot our Serene Prince, *messer lo Doxe*» (ASVE, Ufficiali al Cattaver, b. 3, reg. 5, *Concession de la Schuola, e Matrichula de li Pedotti*, 2 September 1450). The *Cattaver* archive is full of admonitions and pleas against *pedotti* who did not attend to this important duty, such as in 1488 when the Court rebuked those who did «not take into proper account» («fano poco conto») this obligation, (ASVE, Ufficiali al Cattaver, b. 3, reg. 5, *Cerca el remurchiar del bucentoro del di de la Sension*, 21 March 1488).

the Venetians» (Muir, 1981, pp. 118-119)³⁴.

During the Feast of the *Sensa*, in fact, they had to tow both the Doge's ceremonial galley, the *Bucintoro*, and the ship of the Patriarch of Venice³⁵, to the well-known ceremony of the "Marriage of the Sea", the annual claim of sovereignty on the Adriatic Sea. *Pedotti* conducted the temporal and spiritual authorities through the Saint Nicolas port, between the above-mentioned Two Castles, which represented a sort of ceremonial gate for the Doge's triumphal march toward the "Gulf of Venice" (Concina, 1995, p. 250)³⁶. Finally, maybe it was not only a matter of expertise, but an attempt to include these pilots in this liturgical and imperial rite with a view to their role of guardians and ferrymen of the lagoon³⁷.

4. *The constitution of a 'professional minority'*

Obtaining information about those men and their families, especially concerning their origins, is not simple. Moreover, the historian could be misled by scholars, like the same Frederic C. Lane, asserting that 'although they were based in Istria for [the whole] year, these pilots were all Venetian [and] no Istrian was allowed to join their guild or to collect their fees' (Hocquet, 1991, p. 488; Lane, 1973, p. 18)³⁸. On the contrary: Istrian pilots were neither necessarily Venetian nor Istrian (Sambo, 1991, p. 838).

The evolution of the brotherhood's name itself can show us that, between the fifteenth and the sixteenth century, no "national" or "ethnic" origin was required to be chartered on the books of the confraternity. Until the mid-sixteenth century, in fact, in official documents the brotherhood was called "pilots of Venice" or "pilots of Castello", from the city district where they lived, the *Sestriere* called *Castello*³⁹. On the contrary, the term "Istrian pilots" referred to those who actually resided in

³⁴ See also on this topic De Vivo, 2003.

³⁵ The link between *pedotti's* brotherhood and the Patriarchal Seat emerges not only in the *Sensa* ceremony (see for example ASVE, Ufficiali al Cattaver, b. 3, reg. 5, 1493. *Adi 21 marzo. Instrumento fatto del loco de la Schola di pedotti, con Reverendissimo Monsignor Patriarcha, et de la obligation del pedotarlo el di de la Sension, sua Signoria*, 21 March 1493) but also in the strong bond to the Basilica of St. Peter of Castello, where the School had its altar in the chapel of the Holy Cross and *pedotti* had to attend to Masses and processions twice per month (see the first chapter of the above mentioned *Mariegola*).

³⁶ The importance of the *Doi Castelli* in the Venetian ceremonial space is highlighted by Concina (Concina, 1995).

³⁷ Significantly, the *Cattaver* was often appointed to resolve ceremonial and precedence rights conflicts that may arise between the two Admirals of the ports of Lido and Malamocco with regards to the *Sposalizio del Mare* ceremony. See for example ASVE, Ufficiali al Cattaver, b. 281: 24 May 1771.

³⁸ Jean-Claude Hocquet, in fact, is quoting Frederic C. Lane when asserting that Istrian pilots «were all Venetian» (Hocquet, 1991)

³⁹ In venetian, «li pedotti de Venetia», or in latin «Pedotte Castelli», see ASVE, Ufficiali al Cattaver, b. 3, reg. 5, 27 July 1440 and 2 September 1450. See also, for example, ASVE, Ufficiali al Cattaver, b. 3, reg. 5, 1479. *Adi 11 fever in Collegio Duodecim sapientium subsituto locho Consilij Rogator*, 11 February 1480.

Istrian peninsula. Only after the 1540s the term ‘pedotti de Istria’ is used to identify univocally the professional brotherhood⁴⁰, significantly at the end of a hundred years’ process that was leading to the monopolization of the profession in the hands of a small group of families who settled in the neighborhood of Castello.

Besides, during early modern period “Istrian” itself was not an ethnic or national definition (Ivetic, 2000, p. 289)⁴¹. As scholars like Larry Wolff or Egidio Ivetic clearly demonstrated (Ivetic, 2000, 2010; Wolff, 1994, 2001), ‘the ethnic dualism, present in every Istrian context, was not considered a matter of great importance by Venetian or Austrian rulers’ (Ivetic, 2010, p. 11; Salimbeni, 1993, p. 97; Wolff, 2001, p. 128)⁴². The Serenissima, in fact, not only did not recognize «a national distinction between Serbs and Croats among the Slavs» but considered «both Italians and Slavs of Dalmatia as amalgamated members of the same Dalmatian nation» (Wolff, 2001, p. 11)⁴³.

What was decisive in order to become an Istrian pilot, though, was not the “national”⁴⁴ origin, but to take up permanent residence in Venice: in other words, it

⁴⁰ Is at the beginnings of 1541, as far as I know, that appears for the first time in *Pregadi’s* documentation the expression ‘pedotti de Istria’ in its definitive meaning. ASVE, Ufficiali al Cattaver, b. 3, reg. 5, 17 February 1540 *more Veneto* (i.e. 1541).

⁴¹ In 1650, the bishop Tomasini counted five different *genti* (populations) «natives (Italians), Slavs, Morlachs, Grado’s immigrants, *Friulani* and *Carnielli*» (Ivetic, 2000). For a medieval and early modern history of how people identified themselves and where identified in what is now Croatia see Fine, 2006. As anthropological research demonstrates, ‘Istrian identity’ is still a problematic issue, closely linked to political issues, see, Ballinger, 2004. On the “invention of jugoslavism” as a political project during the nineteenth century see, Ivetic, 2012.

⁴² About the Slavic and Morlachs immigrations and settlements in early modern Istria, Fulvio Salimbeni states that a much tenser dialectic exploded only in the nineteenth century, when it will be affirmed «their national conscience». The political choice of Venetian authorities to foster the immigration of these people in Istria, on the contrary, shows «a certain policy by Venice, which had, among other things, created a truly “Commonwealth”, taking also in this context the Byzantine tradition of government, for which all the subjects were the same, as long as they were faithful to Venice and St Mark’s lion: there were no language or racial discrimination, and it is well known that the laws were published in multiple columns side by side with the text in Latin, or in Venetian dialect, in Greek, or “Illyrian”, according to the different local administrative reality. [...] In fact, between the sixteenth and eighteenth centuries, there were no frictions and conflicts of national or ethnic type, as we conceive of them today» (Salimbeni, 1993). «In the nineteenth and twentieth centuries, the Morlacchi were sorted out as Serbs and Croats, according to the categories of modern national identity» (Wolff, 2001).

⁴³ «From a Venetian perspective the most striking social contrast was between the more “civilized” coastal Dalmatians and the inland Dalmatian Morlacchi; moreover, the former were mostly Catholic and the latter largely Orthodox in religion ... In the eighteenth century it was coastal Dalmatians who distinguished themselves from the inland Morlacchi, and the Venetians who recognized and validated that difference» (Wolff, 2001).

⁴⁴ I obviously use the term in its early modern meaning: «generation of men born in the same county, or city» («Generazione d’huomini nati in una medesima provincia, o Città») according to the definition given by the first edition of the *Vocabolario degli Accademici della Crusca*, printed in Venice in 1612. In recent years, scholars have renewed their interest in the subjects of citizenship and nationality in early modern and modern Europe. See Berengo, 1999; Costa, 1999-2001; Herzog,

was necessary to actively demonstrate a willingness to take root in the city by bringing one's own family there (Barbot, 2007, pp. 9-24; Cerutti, 2003)⁴⁵. So, there was a clear attempt to balance apparently contradictory goals: while both the brotherhood and the *Signoria* were trying to force pilots to reside in the two ports of Parenzo and Rovigno⁴⁶, at the same time, as the Council of Pregadi ordered, vessels should embark only pilots «whose families live in Venice».

It is not surprising, though, those Venetian authorities tried to attract pilots from Istria to Venice, promising them benefits and the same rights of local pilots:

Let's take out pilots from Istria, in order to make sure that in our land will be a greater number and better pilots of what currently we have here ... If Istrian pilots will come in this land with their families, they will have the same rights of those who live in this land⁴⁷.

A century later, in 1551, *pedotti's* gathering in Rovigno proves that the “ethnic” or “national” origins of the members of the brotherhood were still varied. The list of *pedotti's* names, shows the presence in the confraternity, for example, of people from Dalmatia, Greece, the northern-eastern Italian region of Friuli⁴⁸, and a number of people whose absence of surname is a clear pointer of a non-Venetian origin (Hocquet, 1991, p. 482)⁴⁹. We can still find a ‘Zanetto de Marco Istrian’ (i. e. Johnny of Marc “the Istrian”) in the *pedotti's* list in 1619⁵⁰.

If we analyse the eighteenth century's gatherings, on the other hand, we can see a much more clear composition of the brotherhood: in this century⁵¹ only a few families, strictly connected through matrimonial relationships, monopolized the School. In January 1763, to take just one example, the thirty pilots participating in

2003. An interesting debate between Peter Sahlins and Simona Cerutti took place on the *Annales* review: see Cerutti, 2007; Sahlins, 2008.

⁴⁵ During the early modern era, citizenship was much more the result of actions certifying the active participation in the community life than an abstract right obtained once and for all. On the primacy of custom over positive law see Grossi, 1997. On the relationship between the stable residence and the citizenship see Benfante, F. & Savelli, A. 2003 (in this issue, see in particular Chauvard, 2003; Tedoldi, 2003; Cerutti, 2003; Barbot, 2007).

⁴⁶ The Senate was often demanded by the brotherhood to punish pilots who do not respect the order to wait the ships in Parenzo and Rovigno. See ASVE, Ufficiali al cattaver, b. 3, reg. 5, 27 July 1440.

⁴⁷ «Sia tolti pedotti de Istria se a ben a proveder a ciò che in questa nostra terra possi esser mazor numero e megior pedotti de quello sono al presente ... se i pedotti d'Istria venissero ad abitar in questa terra con le sue fameglie siano ala condition de li pedotti di questa terra» (ASVE, Ufficiali al Cattaver, b. 3, reg. 5, 6 September 1452).

⁴⁸ As we clearly see by names like: Zorzi «from Zara» (George from Zadar, in Dalmatia); Andrea of Nicolò «from Vegia» (Veglia or Krk, in Dalmatia); Jacomo «Griego» (Greek); Pasqualin «Furlan» (from Friuli, the region of Trieste). (ASVE, Ufficiali al Cattaver, b. 3, reg. 5, *Capitolo delli pedotti fratelli della Schuola del glorioso m.s San Piero*, Rovigno, 11 April 1551).

⁴⁹ Is this the case of people known only under their patronymics: according to Jean-Francois Hocquet (Hocquet, 1991), the habit to identify a person by his provenience or by the name of his father is a clear signal of a non-venetian origin, because the tradition of the surname is well established in the lagoon since the eleven-twelve century. See Addobbati, Bizzocchi & Salinero, 2013.

⁵⁰ ASVE, Ufficiali al Cattaver, b. 3, reg. 5, 22 November 1619.

⁵¹ Incidentally, the one in which we have more documentation.

the monthly profit-sharing, had for the vast majority only three family names, and four out of the only six family names of this list were already part of the brotherhood in the sixteenth century⁵².

This situation, ultimately, is the consequence of what we may regard as a process of the creation of a really interesting “professional minority”, the result of a process driven by different interests. If the *Serenissima*, as we have already seen, was interested in controlling pilots and the navigation in the high Adriatic sea for military and commercial reasons (essentially by hiding lagoon’s secrets from the “foreigners”⁵³, potentially enemies), the brotherhood itself, on the other hand, certainly tried to restrict the access to the profession⁵⁴. It is not surprising that, the *gastaldo* of *pedotti* (the Chief of the brotherhood), in 1491 requested the approval of an amendment to the School Chart including the rule that «as always was observed in our glorious city, and ordered among us, only a son of a pilot, or a “boy” registered [as an apprentice to a pilot], can be enrolled in our profession»⁵⁵.

They were trying, as far as I can understand, to defend their privilege and to maintain the job inside a community of a few kinships (whether based on blood or on “adoption” of an apprentice). Both the interest of the Republic and of the brotherhood, basically, was the expression of the same concern: to defend and to root in the City this particular kind of “local” resource, the job know-how and the knowledge of the territory (i.e. sea-routes and sea-bed).

As Simona Cerutti (2012, p. 185) has pointed out, one of the *raison d’être* of early modern corporations was precisely the control of the young apprentices⁵⁶ and mobile workers, to tie those rootless people to the territory (p. 198)⁵⁷. Instead of

⁵² At the beginnings of 1763 we can find 8 pilots whose surname is Rochello, and respectively 10 Buranella, 8 Miani, 2 Nobile, 1 Ferrara, 1 Galeo. Only the two Ferrara and Galeo where “newcomers”: 28 out of 30 pilots belonged to families already part of *pedotti*’s brotherhood in sixteenth or even fifteenth century (ASVE, Ufficiali al Cattaver, b. 283, *Adi 31 genaro 1762. Poliza del Comparto del sudetto mese fatto da me Bortolo Rochello Gastaldo alli Pedotti*, 31 January 1763).

⁵³ As we have already seen, we may define “strangers” people who did not steadily belong to the community.

⁵⁴ Particularly relevant were conflicts between *pedotti* and other mariner’s guilds, such as «marinarj di San Nicolò di Chiozal (the Chioggia’s School of St Nicolas), see an example in ASVE, Ufficiali al Cattaver, b. 3, reg. 5, 10 July, 16 and 17 September 1638 and 1 June 1639. An analogous mariner’s School of St Nicolas was established in Rovigno.

⁵⁵ «Cum sit che sempre sia stato in observantia in questa nostra gloriosa città, et eciam fra noi ordinato, che algun el qual non sia stato fiolo de pedotta, over fante scritto, non si possa meter a tal nostro exercitio» (ASVE, Ufficiali al Cattaver, b. 3, reg. 5, 1491. *Adi 15 settembre. [settembre] Che algun non possi esser pedotta sel non sarà sta’ fiol de pedotta over fante, sotto pena*, 15 September 1491).

⁵⁶ See an example of legal case issued against a young apprentice, Pietro di Vincenzo Rochello, in ASVE, Ufficiali al Cattaver, b. 138, July-August 1770.

⁵⁷ «[L]’activité de contrôle et donc d’approvisionnement de la mobilité était sans doute l’une des principales raisons d’être des corps de métier. A partir du moment où l’on considérait le travail avant tout comme une ressource locale, la condition pour y accéder était de réussir à faire partie du cercle des ayant droit. En d’autres termes, il était nécessaire de passer du rang d’“étranger” à celui de travailleur, certes mobile, mais enraciné, reconnu, ancré dans le territoire» (Cerutti, 2012). For a summary of the recent scholarly debate on the complex and enormous literature on craft guilds see Epstein & Prak, 2008 and the monographic issue *The Return of Guilds: Towards a Global History of the Guilds in Pre-industrial*

stressing the dichotomy ‘*corps versus étrangers*’ (p. 170)⁵⁸, she suggests an interpretation of craft guilds as a mean of integration, created «comme instances légitimes d’attribution des droits à exercer un métier» (Cerutti, 2012, p. 174).

It seems to me that this interpretation could fit our case. Only “rooted” workers could, in fact, access this particular resource of the territory: job opportunity. This may be the reason why the court of *Ufficiali al Cattaver* ordinarily rejected *pedotti*’s requests for moving their families in Istria, or granted it only for short periods. Pilots often lamented the obligation to be «forced to hold the family in this city, and home in Istria, and suffer many other discomforts and inconveniences»⁵⁹. Nevertheless, the *Cattaver* rarely conceded the grace: this is the case of Mian of Zuanne Miani, who received license to bring his family in Istria «during the whole month of October», or the concession granted to Bortolo Rochello to conduct there his own family «for no more than four months»⁶⁰.

Moreover, as documentation clearly shows, there were plenty of pilots from Istria, Dalmatia, et cetera, able to safely reach Venice through the so-called “parenzana” route⁶¹. Even though the *pedotti d’Istria* incorporated in the School of the Holy Cross were surely experienced pilots, their superior ability was only pretended: the *Ufficiali al Cattaver* had to blame even the venetian authority of Parenzo, the *podestà*, who allowed ships to embark local mariners instead of “approved” pilots⁶².

The corporation, hence, was not primarily meant to assure high quality professional standards but first of all, the presence of a stable bond to the local context. The contrast between norms and exceptions is significant. Usually *pedotti* passed the annual examination, even though they did not meet the requirements⁶³.

Times (Lucassen, J., De Moor, T. & van Zanden, J. L. (2008)). On the “revisionist” interpretation of the economic impact of pre-modern craft guilds see the harsh debate between S. R. Epstein and S. Ogilvie in the *Journal of Economic History*.

⁵⁸ «L’historiographie a longtemps formulé ce problème de manière assez réductrice, en l’envisageant sous l’angle d’une aversion des corps vis-à-vis des étrangers» (Cerutti, 2012). See also the (Epstein & Prak, 2008): «In spite of persistent suggestions to the contrary in the literature, guild petitions and actions against “aliens” were seldom directed against immigrants as such, but rather against non-members, or non-resident aliens. Not only did guilds tolerate migration but, especially in Central Europe, they actively encouraged it».

⁵⁹ «Siamo noi sottoposti a tener la famiglia in questa Città, e la casa in Istria et sentir tanti altri incomodi et disagi» (ASVE, Ufficiali al Cattaver, b. 3, reg. 5, 16 November 1619).

⁶⁰ ASVE, Ufficiali al Cattaver, b. 280, reg. *Pedotti d’Istria, Mandati 1725–1744*. 8 October 1725; 9 January 1726 *more veneto* (i.e. 1727). In these years the *Cattaver* conceded the grace more frequently. It seems to me unusual the case of Pietro Nobile, whose privilege «to conduct his family in Istria, and there continue his profession» was granted directly by the Senate in 1708. See ASVE, Ufficiali al Cattaver, b. 3, reg. 5, 19 April 1708.

⁶¹ It is clearly demonstrated by the numerous legal proceedings against not privileged mariners who piloted ships between Istrian peninsula and the lagoon of Venice against the *Serenissima*’s law. See for example ASVE, Ufficiali al Cattaver, bb. 136-139A.

⁶² See, for example, ASVE, Ufficiali al Cattaver, b. 280, reg. *Pedotti d’Istria, Mandati 1725–1744*, 6 March 1727.

⁶³ See the many requests to be exempt from presenting proof to have accomplished their duties (plumb the depth of the ports and have made at least four travels per year) in ASVE, Ufficiali al Cattaver, bb. 280-283.

Furthermore, as also shown by Simona Cerutti's (2012) case study⁶⁴, it was not professional know-how that gave you the opportunity to enter the brotherhood but the very opposite (pp. 199-201). An example, that may sound paradoxical, should make the point: to become a *pedotta* one must constantly know the exact status of the lagoon seabed, through periodical probes of the depth of the ports of Venice seabed. However, only the members of the brotherhood were allowed, with the permission of the Admirals of the ports, to plumb the depth of the canals of Lido, Malamocco, and Chioggia. Only who was already part of the group was granted access to this sort of local resource, the professional know-how.

5. Istrian pilots as border crossers? Some final remarks

To conclude my contribution, I would like to devote a few words on the life of the Pilots in Istria, and their relationship with the local communities of Rovigno and Parenzo. This might probably suggest that they could have acted as mediators between the two sides of the Adriatic sea⁶⁵.

Istria was a land full of conflicts⁶⁶, a frontier region, crossed by religions, populations and a land of smugglers and bandits⁶⁷. The privileged "Istrian Pilots" (the venetian ones) certainly had conflicts throughout the early modern period against smugglers: «to smuggle – is said in a report – in some lands and especially in Rovigno and Pirano, is considered almost a right» (Ivetic, 2000, p. 216).

The disputes against the mariners of Istria, accused by the venetians to illegally pilot ships toward Venice, were frequent⁶⁸. In some cases the conflict reached critical peaks, as in 1622, when the Rector of Rovigno wrote that 'unknown malicious people plunged two big bull's horns into the door of *Pedotti's* house', just in front of the Rector Palace (Budicin, 1998, p. 159)⁶⁹: an incontrovertible warning sign

⁶⁴ With regards to shoemakers' guild the historian points out that «les syndics des corporations utilisent souvent la provenance des matières premières comme un critère implacable d'exclusion ... Tout bien considéré, dans le cas des cordonniers, la connaissance locale exigée ... concerne la connaissance du territoire et de ses ressources». Also, «Nos sources emploient ... le vocabulaire du savoir-faire et de l'aptitude au métier. Mais ces derniers sont rarement présentés comme des qualités personnelles, qu'un individu posséderait indépendamment du contexte social ou matériel. Le savoir-faire est décliné en termes d'appartenance: c'est un savoir local, dont on mesure localement l'efficacité» (Cerutti, 2012).

⁶⁵ For a useful bibliographical review essay on British imperial history facing "global history" and "connected histories" perspectives see Stern, 2009. On the Dutch case study see, Kaplan, Carlson & Cruz, 2009.

⁶⁶ As shown, for example, by the dispatches of Venetian Rectors in Istria to the *Capi del Consiglio dei Dieci*, ASVE, Capi del Consiglio dei Dieci, Dispacchi dei Rettori, b. 266 (Parenzo) and b. 272 (Rovigno).

⁶⁷ See Ivetic, 2000.

⁶⁸ See, for example, the legal cause issued against Domenico Benussi, alias Nicolò Benussi (alias *Battello*, i.e. Boat), «non-*pedotta* Istrian mariner» in 1727, ASVE, Ufficiali al Cattaver, b. 136, 27 February 1726 *more veneto* (i.e. 1727)-15 June 1728.

⁶⁹ The 'house of pedotti' appears in a drawing of Rovigno's main square. See in Budicin, 1998.

towards business and contraband rivals⁷⁰. Major local ship-owners, such as the Benussi family in Rovigno⁷¹, were particularly active in smuggling, and they often led uprisings against Venice's Rectors. It is the case of *patron* (owner) Giusto Benussi, for example, whose gang in 1656 shot a Rector's servant responsible to have notified him a chancellor charge⁷².

However, if conflict was inevitable, it did not necessarily involve everyone. In spite of a strong tendency towards endogamy, in fact, a few testaments I was able to find in the State Archives of Venice suggests the existence of matrimonies between pilots' daughters and people likely hailing from Istria or Dalmatia: for example, this appears to be the eighteenth century case of Angela Buranella, married with the merchant Giacomo⁷³. At the same time, other testaments show us the acquisition of real estate property rights in Istria by pilots' families, as in the case of Damian Miani married to Caterina Negri (two *pedotti's* kinships), who owned a 'revenue proceeding from a house in Parenzo', received by Caterina from her mother as a dowry⁷⁴.

These examples are only the first results of a research still in progress. But it is not meaningless to highlight what this kind of sources, if systematically exploited, could reveal us: on the one hand, these remarkably mobile workers, regardless of their origin (Venice, Istria, Friuli, Dalmatia, Greece, etc.), were controlled and rooted in the city of Venice by the corporate body, whilst on the other hand, to use a metaphor, they probably did much more than simply "ferrying" goods and ships. One of the most interesting path of research in the future then would be to explore and document more in detail the role of *pedotti* as border-crossers that connect networks of people in particular with matrimonial strategies, land investments, commercial relationships both legal and illegal, and become a mediator between the worlds of the Capital, Istria, and international trade itself.

References

- Addobbati, A., Bizzocchi, R., & Salinero, G. (2013). *L'Italia dei Cognomi: L'Antroponimia italiana del quadro mediterraneo*. Pisa: Pisa University Press.
- Ballinger, P. (2012). "Authentic Hybrids" in the Balkan Borderlands. *Current Anthropology*, 45(1), 31-60.

⁷⁰ ASVE, Capi del Consiglio dei X, Dispacci dei Rettori, b. 272, Giacomo Barbaro to the Capi del Consiglio dei X, 5 May 1622.

⁷¹ See Colak, 1969 & 1972.

⁷² Giusto Benussi was involved in olive oil smuggling with *patron* Piero Biancone from Caurle (probably, Caorle, a port only a few miles to the north of Venice). See ASVE, Capi del Consiglio dei X, Dispacci dei Rettori, b. 272, 7 February 1655 *more veneto* (i.e. 1656).

⁷³ ASVE, Notarile, Testamenti, b. 233, n. 45: Copy from *Libro dei Morti della Chiesa Patriarcale di Venezia, Adi 24 settembre 1783*, 24 September 1783.

⁷⁴ ASVE, Notarile, Testamenti, b. 1158, n. 158: Last will and testament of Damian Miani quondam Bernardin, notarized by Bortolamio Cardinali, 17 May 1760.

- Barbot, M. (2007). Abitare, dunque appartenere: Inclusione ed esclusione nelle città italiane di Antico Regime. *Zapruder*, 14, 9-24.
- Benigni, U. (1912). Venice. In *The Catholic Encyclopedia* (Vol. 15). Retrieved 7 January 2013, from <http://www.newadvent.org/cathen/15333a.htm>
- Benfante, F. & Savelli, A. (Eds.), (2003). Proprietari e inquilini. *Quaderni Storici* 38 (2).
- Berengo, M. (1999). *L'Europa delle città. Il volto della società urbana europea tra Medioevo ed Età moderna*. Turin: Einaudi.
- Bevilacqua, P. (1995). *Venezia e le acque: Una metafora planetaria*. Rome: Donzelli Editore.
- Bordone, R., Guglielmotti, P., Lombardini, S., Torre, A. (Eds.), (2007). *Lo spazio politico locale in età medievale, moderna e contemporanea: Atti del convegno internazionale di studi (Alessandria, 26-27 novembre 2004)*. Alessandria: Edizioni dell'Orso.
- Budicin, M. (1998). *Aspetti storico-urbani nell'Istria veneta: Dai disegni dell'Archivio di Stato di Venezia*. Trieste: Italian Union.
- Calabi, D. (1991). Canali, rive, approdi. In U. Tucci, & A. Tenenti (Eds.), *Storia di Venezia: Il Mare* (Vol. 2., pp. 767-768). Rome: Istituto dell'Enciclopedia Italiana.
- Caniato, G. (1995). L'organismo delicato: il governo idraulico e ambientale. In G. Caniato, E. Turri, & M. Zanetti (Eds.), *La laguna di Venezia* (pp. 139-151). Verona: UNESCO.
- Caravale, M. (1997). Le istituzioni della Repubblica. In G. Arnaldi, G. Cracco, & A. Tenenti (Eds.), *Storia di Venezia: La formazione dello stato patrizio* (Vol. 3., pp. 319-326). Rome: Institute of the Italian Encyclopedia Treccani.
- Cassandro, G. (1981). La genesi del Codice per la veneta mercantile marina. *Archivio Storico Pugliese*, 34, 281-300.
- Cerutti, S. (2003). *Giustizia sommaria. Pratiche e ideali di giustizia in una società di Ancien Régime (Torino XVIII secolo)*. Milan: Feltrinelli.
- Cerutti, S. (2007). A qui appartiennent les biens qui n'appartiennent à personne? Citoyenneté et droit d'aubaine à l'époque moderne. *Annales HSS*, 42(2), 355-383.
- Cerutti, S. (2012). *Étrangers: Étude d'une condition d'incertitude dans une société d'Ancien Régime*. Montrouge: Bayard.
- Chauvard, J. (2003). Rendita, diritto e morale. Proprietari e inquilini in età moderna. *Quaderni Storici* 38 (113), 305-323.
- Ciriaco, S. (1998). Il governo del territorio: l'ambiente urbano e la laguna. In P. Del Negro, & P. Preto (Eds.), *Storia di Venezia: L'ultima fase della Serenissima* (Vol. 3., pp. 613-650). Rome: Istituto dell'Enciclopedia italiana.
- Colak, N. (1969). Navigazione marittima fra i porti dalmato-istriani e i porti pontifici alla fine del Settecento. *Studi Veneziani*, 1, 583-636.
- Colak, N. (1972). Navigazione marittima fra i porti dalmato-istriani e i porti pontifici alla fine del Settecento. *Studi Veneziani*, 4, 227-354.
- Concina, E. (1995). Le fortificazioni lagunari fra il tardo Medioevo e il secolo XIX. In G. Caniato, E. Turri, & M. Zanetti (Eds.), *La laguna di Venezia* (pp. 249-269). Verona: UNESCO.
- Costa, P. (1969). *Iurisdiction: Semantica del potere politico nella pubblicistica medievale: 1100-1433*. Milan: Giuffrè.
- Costa, P. (1999-2001). *Civitas: storia della cittadinanza in Europa*. Rome-Bari: Laterza.
- Crouzet-Pavan, É. (1988). Le port de Venise à la fin du moyen âge: entre la lagune et la ville un 'effet' portuaire? In S. Cavaciocchi (Ed.), *I porti come impresa economica: Atti della diciannovesima Settimana di studi: 2-6 maggio 1987* (pp. 625-652). Florence: Le Monnier.
- De Vivo, F. (2003). Historical Justifications of Venetian Power in the Adriatic. *Journal of the History of Ideas*, 64(2), 159-176.
- Dorigo, W. (1995). Fra il dolce e il salso: origini e sviluppi della civiltà lagunare. In G. Caniato, E. Turri, & M. Zanetti (Eds.), *La laguna di Venezia* (pp. 137-191). Verona: UNESCO.
- Dotson, J. (2003). Venice, Genoa and Control of the Seas in the Thirteenth and Fourteenth Centuries. In J.B. Hattendorf, & R.W. Unger (Eds.), *War at sea in the Middle ages and the Renaissance* (pp. 130-133). Woodbridge, VA: Boydell.

- Epstein, A. S. (1996). *Genoa and the Genoese: 958–1528*. Chapel Hill & London: The University of North Carolina Press.
- Epstein, S. R. (2008). Craft Guilds in the Pre–Modern Economy: A Discussion. *Journal of Economic History*, 61(1). 155–174.
- Epstein, S. R., & Prak M. (Eds.), (2008). *Guilds, Innovation and the European Economy, 1400–1800*. Cambridge: Cambridge University Press.
- Fine, Jr. J. (2006). *When ethnicity did not matter in the Balkans: A study of identity in pre–nationalist Croatia, Dalmatia, and Slavonia in the medieval and early–modern periods*. Ann Arbor: University of Michigan Press.
- Grossi, P. (1997) *L'ordine giuridico medievale*. Rome-Bari: Laterza.
- Herzog, T. (2003). *Defining Nations: Immigrants and Citizens in Early Modern Spain and Spanish America*. New Haven, CT: Yale University Press.
- Hocquet, J. (1991). La gente di mare. In U. Tucci, & A. Tenenti (Eds.), *Storia di Venezia: Il Mare* (Vol. 2., p. 482). Rome: Istituto dell'Enciclopedia italiana.
- Ivetic, E. (2000). *Oltremare: L'Istria nell'ultimo dominio veneto*. Venice: Istituto Veneto di Scienze.
- Ivetic, E. (2010). *L'Istria moderna (1500–1797): Una regione confine*. Verona: Cierre.
- Ivetic, E. (2012). *Jugoslavia sognata: Lo jugoslavismo delle origini*. Milan: Franco Angeli.
- Kaplan, B., Carlson, M., & Cruz. (2009). *Boundaries and their Meanings in the History of the Netherlands*. Boston, MA: Brill.
- Lane, C. F. (1973). *Venice: A Maritime Republic*. Baltimore, MD: John Hopkins University Press.
- Lucassen, J., De Moor, T. & van Zanden, J. L. (2008). The Return of the Guilds: Towards a Global History of the Guilds in Pre-industrial Times. *International Review of Social History*, 53(16), 5–18.
- Mackenney, R. (1987). Tradesmen and traders: The world of the guilds in Venice and Europe, c. 1250–c. 1650. *The International History Review*, 9(4), 662–664.
- Martini, A. (1883). *Manuale di metrologia, ossia misure, pesi e monete in uso attualmente e anticamente presso tutti i popoli*. Turin: Loescher.
- Morachiello, P. (1991a). Le bocche lagunari. In U. Tucci, & A. Tenenti (Eds.), *Storia di Venezia: Il Mare* (Vol. 2., pp.77–110). Rome: Istituto dell'Enciclopedia italiana.
- Morachiello, P. (1991b). Fortezze e lidi. In U. Tucci, & A. Tenenti (Eds.), *Storia di Venezia: Il Mare* (Vol. 2., pp. 111–134). Rome: Istituto dell'Enciclopedia italiana.
- Muir, E. (1981). *Civic ritual in Renaissance Venice*. Princeton, NJ: Princeton University Press.
- Ogilvie, S. (2008). Rehabilitating the Guilds: A Reply. *Journal of Economic History*, 61(1). 175–182.
- Pagratís, D. G. (2006). “Le fortune di mare.” Incidenti della navigazione mercantile nei mari Ionio e Adriatico (1611–1795). In S. Cavaciocchi (Ed.), *Ricchezza del mare ricchezza dal mare: secc. XIII–XVIII Atti della trentasettesima Settimana di studi, 11–15 aprile 2005* (Vol 2., pp. 841–861). Florence: Le Monnier.
- Parento, A. (1897). Gli esami dei “Pedotti” d’Istria. *Atti e Memorie della Società istriana di Archeologia e Storia Patria*, 12(1-2). 37–56.
- Pearce, J. (Ed.), (2009). *The Merchant of Venice: With Contemporary Criticism*. San Francisco, CA: Ignatius Press.
- Rossi, F. (1991). Le magistrature. In U. Tucci, & A. Tenenti (Eds.), *Storia di Venezia: Il Mare* (Vol. 2., pp. 688–694). Rome: Istituto dell'Enciclopedia italiana.
- Rinaldo, A. (2009). *Il governo dell'acqua. Ambiente naturale e ambiente costruito*. Venice: Marsilio.
- Sahlins, P. (2004). *Unnaturally French. Foreign Citizens in the Old Regime and After*. Ithaca, NY: Cornell University Press.
- Sahlins, P. (2008). Sur la citoyenneté et le droit d’aubaine à l’époque moderne. Réponse à Simona Cerutti. *Annales HSS*, 43(2). 385–398.
- Salimbeni, F.(1993). L’età moderna. In F. Salimbeni (Ed.), *Istria. Storia di una regione di Frontiera* (p. 97). Brescia: Morcelliana.
- Sambo, A. (1991). Il lavoro portuale. In U. Tucci, & A. Tenenti (Eds.), *Storia di Venezia: Il Mare* (Vol. 2., pp. 837–843). Rome: Istituto dell'Enciclopedia italiana.
- Stern, P. J. (2009). Neither East nor West, Border, nor Breed, nor Birth: Early Modern Empire and Global History. *Huntington Library Quarterly*, 72(1), 113–126.

- Tedoldi, L. (2003). Locazioni e integrazioni sociali nella Brescia Veneta (XVII–XVIII secolo). *Quaderni Storici*, 38(113), 381–398.
- Tenenti, B. (1979). Note sui tassi adriatici d'assicurazione nella prima metà del Cinquecento. *Studi Veneziani*, 3, 187–202.
- Tenenti, B. (1980). Ragusa e Venezia nell'Adriatico della seconda metà del Cinquecento. *Studi Veneziani*, 4, 99–128.
- Torre, A. (2011). *Luoghi: La produzione di località in età moderna e contemporanea*. Rome: Donzelli.
- Tucci, U. (1991). La pratica della navigazione. In U. Tucci, & A. Tenenti (Eds.), *Storia di Venezia: Il Mare* (Vol. 2., pp. 527–559). Rome: Istituto dell'Enciclopedia italiana.
- Wolff, L. (1994). *Inventing Eastern Europe: The Map of Civilization on the Mind of the Enlightenment*. Stanford, CA: Stanford University Press.
- Wolff, L. (2001). *Venice and the Slavs: The Discovery of Dalmatia in the Age of Enlightenment*. Stanford, CA: Stanford University Press.
- Zannini, A. (2012). Un ecomito? Venezia (XV–XVIII sec.). In G. Alfani, M. Di Tullio, L. Mocarelli (Eds.), *Storia Economica e Ambiente italiano* (pp. 100–113). Milan: Franco Angeli.
- Zucchetta, G. (2000). *Storia dell'acqua alta a Venezia dal Medioevo all'Ottocento*. Venice: Marsilio.

Archives

ASVE. Archivio di Stato di Venezia.

*Intangible Cargo / Elusive Itineraries. Traveling Intellectuals, Experts, Advisers and Artist at Byzantine, Ottoman and Renaissance courts**

SLOBODAN DAN PAICH

1. Mediterranean water currents

Often as historians or cultural historians we view the sea as an expanse of water, scenery framing events or something that is just there. Each ocean and sea has their own characteristics that influence, shape and participate in the making of history. Below are the diagrams of water currents in the western and eastern Mediterranean

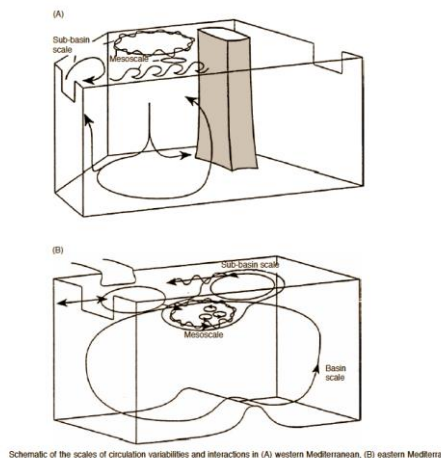

* The contribution of Slobodan Dan Paich is the result of a peculiar and rather unique performance delivered on the occasion of the conference. The author brought together visual and literary evidence in quite sophisticated and creative manner creating a succession of Mussorgskian pictures and tableaux. Therefore, we decided to retain a glimpse of the author's theatrical and sophisticated way of delivery by omitting some punctual references to the Homer's literary works quoted in the paper (*Note of the editors*).

The lines from the play *Tarantella, Tarantula* (2006), the introductory narration, loosely based on the scientific paper *Mediterranean Sea Circulation*, express the richness and idiosyncrasies of the Mediterranean (Leslie & Robinson, 2001, p. 1689):

Deep-water currents jet from Spain to Algeria across the Mediterranean. Further east, the deep but narrow current widens and fans out horizontally as it approaches the island of Sardinia. The unstable currents create eddies many miles wide which meander up the coasts. Cyclonic eddies stir the sea for days, but the anti-cyclonic eddies churn for weeks or even month in the depths. The open sea eddies often alter the expected currents, channeling the waters into unstable and unpredictable patterns, particularly present in the waters of Sicily. Two jets join just south of Corsica to form the powerful Catalan current.

Anglers and merchants from Illyria, Crete, Phoenicia, Egypt, and Greece braved these currents to establish colonies and settlements away from home. They sought—and brought—grapes and goats, linen and lavender. They carried gold and tin, cheese and salt, olive oil, wine, and purple dye. They traded in herbs and medicines.

And their stories, songs, and dances ended up in the Homer's epics.

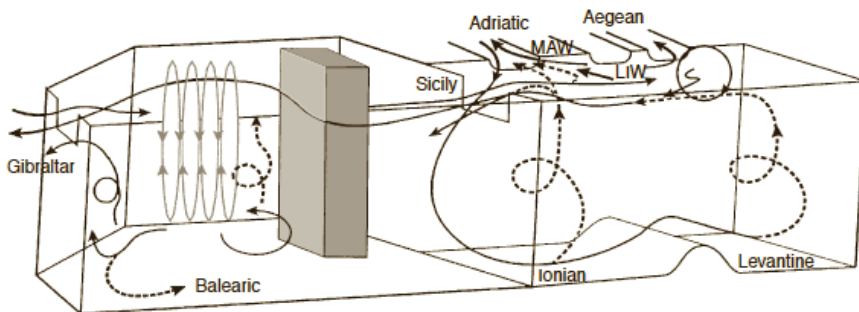

... Schematic of thermohaline cells and path of Levantine Intermediate Water (LIW) in the entire Mediterranean.

2. *Odysseus and Mediterranean*

Indeed, if we compare the diagram of the sea currents of the Mediterranean with a hypothetical map and description from Homer's *Odyssey*, we may see the great epic as homage to the ancient navigators and their relationship, knowledge and struggles with the Middle Sea. This is particularly poignant in the description of Odysseus dealing with the treacherous waters of the Straits of Messina, which lies between and divides Sicily and Italian mainland, personified as two monsters Scylla and Charybdis inhabiting the cliffs and waters on the opposite banks of the straits.

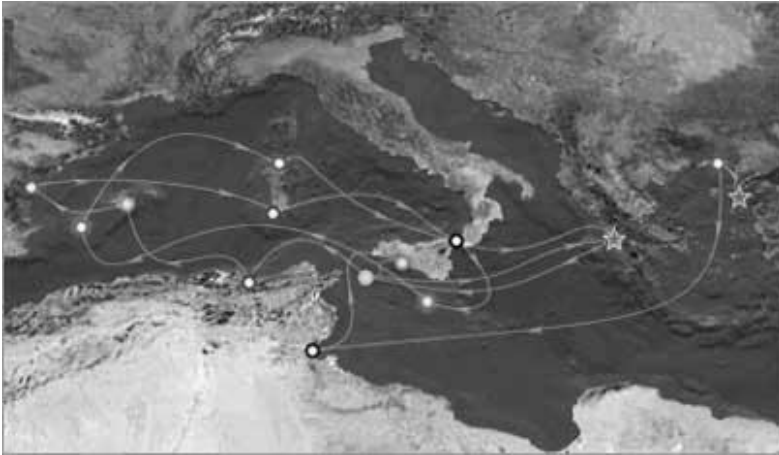

While going through the bottleneck of the two cliffs, Scylla and Charybdis, Odysseus navigated away from the whirlpool of Charibdis that «[...] terribly sucked down the salt water of the sea. [...] she would seethe and bubble in utter turmoil, and high over head the spray would fall on the tops of both the cliffs». Odysseus fully armed at the prow was ready to face Scylla and protect his men, when behind his back six of his crew were lifted out of the ship as if by a great wave:

Then at her doors she devoured them shrieking and stretching out their hands toward me [Odysseus] in their awful death-struggle. Most piteous did mine eyes behold that thing of all that I bore while I explored the paths of the sea.

Odysseus as a great and experienced captain could read the sea and with the remaining men, squeeze out of the danger.

3. *Black Sea*



The Black Sea is characterized by having two distinct layers. The bottom layer below 150 feet or 50 meters is depleted of oxygen and inhospitable to flora or fauna. Only the relatively shallow top layer has life in it. These facts are in part the result of water exchanges between denser, salt-rich Mediterranean waters with the Black Sea waters that are lighter with plentiful river effluents. One of the major contributors to these sweet water riches of the Black Sea is Danube that traverses half of the European continent. Danube was known to Sumerians under the name Istar (Teleki, 1967). This is most likely the same Istar navigated by Jason and The Argonauts on their return journey. Trained on the Mediterranean currents and characteristics, the ancient Greek mariners found the Black Sea inhospitable originally and named it as such until they understood it.



Jason a lone survivor of his family and the legitimate heir to Tesali's throne was hidden and raised in the wild. Once fully grown and trained fate brought him seemingly by chance to the usurpers festivities honoring a neighboring king. In the physiological tag of youth innocence and usurpers cunning, Jason was sent on the impossible journey to fetch the Golden Fleece. He was promised that if he succeeded, he would regain his father's throne. To achieve this goal Jason assembled a crew of the fifty most remarkable young men of his day, the Argonauts. After many adventures and trials, the outcome was successful for Jason, he obtained the Golden Fleece and regained his rightful kingdom. However, the outcome of the story was devastating for the original owners of the Golden Fleece, the Kingdom of Colchis (today Western Georgia) and their King Aetes, his son Apsyrtus and daughter Medea.

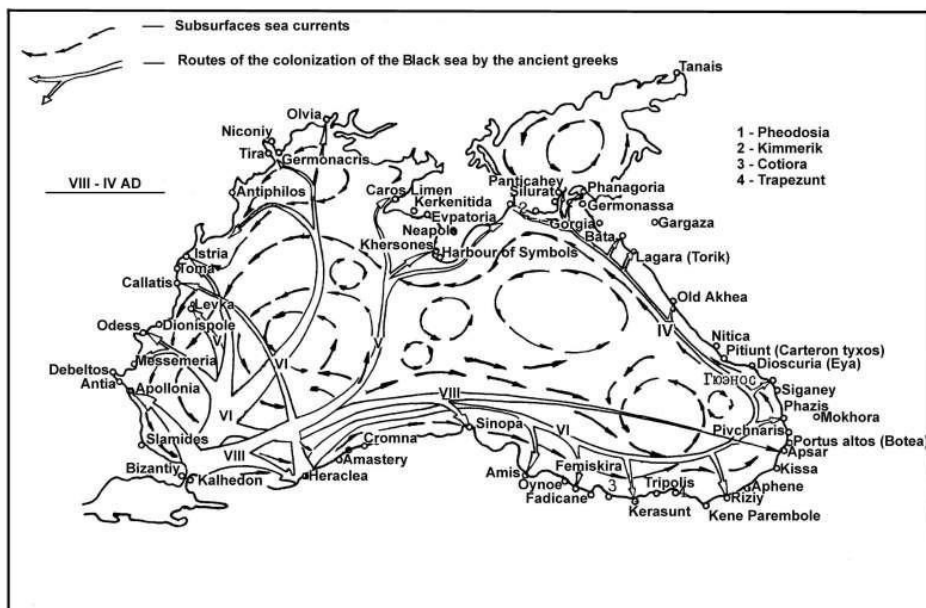

In the context of our paper, there are several elements of the Argonauts Story that are related to exchanges, values, sea routes and trade routes forming the history of Mediterranean and its neighbor. Jason and the Argonauts were role models for generations of maritime explorers and colonizers and epitomized the maritime strength of the Ancient Greek culture. The Argonaut epic point out that Colchis was already a Greek colony before Jason’s time. The presence and fascination with gold, the praised commodity of Colchis, the region of Jason’s quest is implied in the story. The eastern banks and lands of the Black Sea were famed for abundance of gold. This fascination reflects in the artifacts from the Black Sea’s eastern shores. Particularly in Scythian Gold produced later in the 4th and 3rd century BC by Greek and Scythian craftsmen trading in the lands of and adjacent to the territory of Jason’s quest. The extent of Ancient Greek influences and trade routes spans from eastern and particularly southern shores of The Black Sea via the eastern Mediterranean to southern Italy, Sicily and with the founding of Alexandria to Egypt.

4. Atlantic and Phoenician trade routes

At the most western point of the Mediterranean where Africa and Europe almost touch and Spain and Morocco are facing each other, the Atlantic and Mediterranean meet and mix at the narrow Gibraltar Straits, almost 15 kilometers wide, approximately 9 miles. There are similar water differences occurring at the meeting of the Mediterranean and the Black Sea. Compared with the Atlantic, the Mediter-

anean Water is heavier, warmer and richer in salt. The saltier waters, before merging completely with the Atlantic create currents a mile or so long out into the open ocean, while the lighter Atlantic water rushes in and creates coastal currents pushing towards the east. Phoenicians, master navigators have used these currents to reach and return from ancient Britain trading and bringing tin, the essential ingredient that with copper alloys into bronze. With navigational and strategic know-how, the Phoenicians were able to protect their interest and dominance of the Western Mediterranean and Atlantic for a thousand years.



Phoenicians knew the currents within Mediterranean centuries before Greeks caught up with the knowledge. They seem to particularly use the general anti-clock direction of the currents, navigating from island to island and then the coast of southern France, Spain, going west and following the African coast going east. Phoenicians understood shipbuilding and ship defense and were invincible until the Roman period of the Punic Wars. They also understood the economy of demand and supply and traded in specialized products like silver, tin, and purple dye. They introduced the idea of silver coinage and supplied the raw material. Like Venetians in the Middle Ages and Renaissance, Phoenicians brought prosperity to wherever they settled.

5. Venetians and neighboring watersheds

Lunde (2005, pp. 4-11) writes about the Venetian codependency on Arab maritime power in the Middle Ages that had grown out of the Arab merchants' precise understanding of the monsoon patterns in the Indian Ocean watershed. He also analyzes the origins of the word monsoon, which sheds light on the importance and cosmopolitan influence of Arab maritime power prior to European sea exploration. He further describes how the regular sailing of the Venetian convoys, the mude, were synchronized with the Indian Ocean monsoon trade winds.

The economies of northern Europe were similarly linked – indirectly, like a train of interlocking gears – to the Indian Ocean monsoon: From Venice, after the return of the mude, spices and textiles traveled overland and by internal waterways to the trade fairs of northern Europe. (Another set of gears driven by the monsoon linked the Indian Ocean economies with China) The Venetian trade monopoly in the Mediterranean was established after the Venetians led the 1204 crusade against Constantinople, and secured treaties with the Mamluk Sultan.



While merchants such as the Venetians developed their trades, they set a primary value on gold. In contrast, the aristocrats' power was derived from land; for musicians, teachers, court advisers, and other itinerant experts, their currency was their skills. Sometimes, those skills could outweigh any amount of gold, and gained them entrance and employment at the inspiring and vital courts of Aquitaine, Galicia, or Damascus. Lunde continues:

In the Islamic world, gold was a tool. Mocenigo's equation, in which fear and respect could be had for gold, would have sounded blasphemous to Muslims, for whom it is God alone who commands fear and respect. Muslims believed that gold and silver must circulate, and this circulation, called *rawaj*, was a social and religious duty (Lunde, 2005).

The symbiosis of medieval maritime trade must have had an effect on phenomena such as the Troubadours and other itinerant culture-workers. All of these transactions had to be communicated with a shared language for international communication and expression, a *lingua franca*.

6. *Ziryab - Abu l-Hasan 'Ali Ibn Nafi*

Musician Ziryab - Abu l-Hasan 'Ali Ibn Nafi (789 – 857) was trained as a youth in his Native Baghdad then traveled through Damascus with a sojourn in North

Africa before settling in Spain as a court adviser. Ziryab arrived in Cordoba in 822 at the age of 43 and was welcomed by Al-Hakam II who honored his recently deceased father's invitation. To understand the journey of Ziryab is to understand the journey and survival of the Umayyads and Al-Hakam I. Like the refugee prince before him, Ziryab's journey must have been on land through Arab territory and kingdoms, but with the Mediterranean, the White Middle Sea – al-Baḥr al-Abyaḍ al-Mutawassit, providing a natural and cultural presence beyond being scenic background. [We learned from the Phoenician history that the African coast was more navigable west to east due to currents and perhaps prevailing winds of colder Atlantic air being sucked by the hotter lighter air of Africa.] The prince Al-Hakam I in his exile from Damascus had to manage a vast territory, a number of kingdoms and potentially treacherous allegiances before he finally crossed Gibraltar into the Iberian Peninsula and unified disparate interests into the kingdom.

It is rare for a stranger to be embraced and allowed to bring so much influence. Politics, economics and inter-cultural policies all combined to make Al-Andalus one of the most advanced societies of its day, famed for its conviviality, art, music, architecture and religious tolerance. In the history of the Middle Sea the ebb and flow of periods of flourishing, conviviality and security are constantly parallel or followed by strife, conflict, unrest and intolerance. The itinerant advisers, scholars, and artist play a part in it. The example of Ziryab's contribution to Iberian music, general culture and mores is a part of the history of the elusive Mediterranean conviviality. Conviviality is a complex social interplay of many elements, but legislative framework and cultural dynamics can be setup to facilitate daily practice of mutual understanding. Umayyads, Abbasids and Muslim empires in Andalusia and Mogul kingdoms in India managed to sustain religious diversity and pluralism in their own time. Based on the general attitude in Islam that recognized the Abrahamic religions as equally reviled helped to institutionalize in certain historic periods the coexistence of Islam, Christianity, and Judaism in free religious practice, law, forming of business associations, protection and education. Following those earlier examples, The Ottoman Empire inherited the Arab Convivencia of the middle ages and created a unique legal and political instrument, the millet or community system, that made possible the coexistence of diverse Christians from the Balkans to the Caucasus, Jews and a majority of Muslims under the same political system and social domain for centuries.

The example of the Ottoman legislation and diversity management is introduced briefly to give as a comparative idea of the cultural climate and aspirations of an earlier time where Ziryab's contributions found a fertile ground (Bardakoglu, 2008, p. 115). Summarizing Ziryab's life and work will open reflection on the dynamic of the traveling intellectuals, experts, advisers and artists at medieval and renaissance courts. Considering that Ziryab was first and foremost a great musician, let's first look briefly to the tradition from which Ziryab came from, the Persian Classical music. Over centuries Persian music influenced Arab, Indian, Andalusian, medieval Troubadour, courtly music of Europe, Western China and Ottoman styles

and practices. In Persian classical music the lead singer or instrumentalist is the master of the palpable, communicable mood of the performance. He conducts with his voice and instrument guiding other musicians in an ensemble performance. Often the other musicians are his relatives and disciples. Apprentices have well-defined and traditional relationship to the master musician, who is called Ostad.

The appellation Osted is similar to the European title Maestro (for the public), akin to the Indian Music Guru (for his students) and reminiscent to the Japanese title of National Treasure (for his Patron and supporters). Persian classical music is an interplay of improvisation and pre-arranged composition and is based on a series of modal scales and tunes which must be memorized. The repertoire consists of more than two hundred short melodic movements, which are classified into seven “modes”. Out of this cultural context and tradition emerges Ziryab as a king of musicians, inspired performer and composer, music tradition keeper as well as innovator, instrument maker and teacher.

Ziryab dissidence and exile

Baghdad is speculated as Ziryab’s place of birth. He must have had early training even as an infant as he became fully proficient in musical skills demanding technical dexterity by the time he was in his early teens. Including all of his other gifts, this musical dexterity allowed him to comprehend, understand and memorize his teacher’s work that would be impossible for a teenager or a young adult who recently started. Ziryab, who was nicknamed Blackbird because of his dark skin, was thought by some scholars to be a freed slave. If that was the case, he was probably second or third generation because he was well versed, adjusted to intricacies of court life and at home with rulers and kings. Even as a young man he was naturally part of the cosmopolitan circles of courtiers and advisers.

In the ancient and more modern times and until the industrial revolution, people inherited the profession of their family and parents, as was the case with Mozart and Beethoven. So probably Ziryab’s mother was a court singer of considerable gifts, wisdom, allure, renown and of a remote ethnicity unusual in Baghdad, maybe Ethiopian, south Indian or North African. Almost all of the sources give Zirjab Persian, Kurdish or African origins. His father may have been Persian/Kurdish, either a highly placed musician or a court official and perhaps a protector if not a husband of Ziryab’s mother.

Music was considered sinful even blasphemous among certain judges and religious circles of Islam. To get around this the ancient Arab speaking world employed non-Muslims or foreigners to perform the music. A dark, beautiful, cultured Indian or African woman musician and her Persian protector and consort would be a perfect answer to the Arab court’s need of music and musicians. Against some scenarios, like the tentative reconstruction above with Ziryab already remarkably accomplished as a youth, would contextualize Ziryab strategically and wisely apprenticing himself to the leading singer of his time Ishaq al-Mawsili at the court of

Harun al-Rashid. As he learned everything he could he began to take the music to greater heights, including improving instrument building.

Traditionally an apprentice who is not a family member had a very small chance of inheriting his teacher's post at the court. He would have to wait for a long and uncertain time and hide his gifts as not to offend his teacher. Ziryab's reputation was growing probably through some courtiers visiting Ishaq al-Mawsili's classes or the master performing with his student at their house concerts. The reports of Ziryab's quality reached Harun al-Rashid so the king wanted to hear him. Ishaq al-Mawsili was amiable as this was a testament of the quality of his school and instruction demonstrated before the king. Tradition implied extreme deference to the master presenting his pupil. Ziryab's temperament was not that of a minor court musician content with security of a job, instead he took risk and approached the king. Ziryab knew that if he didn't show honestly his ability at this meeting, a prolonged and surreptitious rivalry behind the scene would happen sooner or later in which he would have no access to the king's ear. Julian Ribera in his book *Music in Ancient Arabia and Spain* describes the event in a staged dialog.

Then followed a question (from the king) about his skill, and Ziryab answered:

I can sing what the other singers know, but most of repertory is made up of numbers suitable only for performance before a Caliph like Your Majesty. The other singers do not know this. If Your Majesty will permit, I will sing for you what human ears have never even heard (Ribera, 1929, p. 101).

Julian Ribera describes how the Caliph ordered that Ishak's lute should be handed to him, but that Ziryab declined, saying that he brought his own lute and left it with the guards. It was made by him as no other was suitable. Harun sent for it and after an examination, it seemed that the two instruments were almost identical. Julian Ribera continues:

Caliph said: "Why were you unwilling to use your master's lute?"

"If the Emir desire me to sing in my master's style, I will sing with his lute, but if I am to sing in my own style, I must play my own instrument."

"They seem alike to me," answered Harun.

"At first view, yes; but even if the size and wood are the same, the weight is not, My lute weighs about a third less than Ishak's and my strings are made of silk that has not been spun with hot water, which weakens them. The bass and third strings are made of lion guts, softer and more sonorous than those from any other animal. These strings are stronger than any others and withstand better the striking of the plectrum" (Ribera, 1929, pp. 101-102).

Years wondering

Julian Ribera describes how after that meeting, Ishaq al-Mawsili was unable to bear competition at the court. He asked Ziryab to either leave to some distant place where he would never hear of him again, and he offered to finance the exile, or if Ziryab remains at the Baghdad Court, he would use all means to ruin him. Ziryab chose exile and went to the west towards new frontiers of North Africa and Al-Andaluse in Spain. He sojourned for a while in Ifriqiyya, present day Tunisia, at

the Aghlabid court. The arrangement seemed to be reasonable if not fulfilling and it gave Ziryab opportunity to build a reputation and respect among his colleagues and connoisseurs prior to being invited to Al-Andalus by the Umayyad prince, Al-Hakam I.

Years of full participation

Ziryab crossed the Straits of Gibraltar to Algeciras with his family in 822. Julian Ribera tells us that there he received the tragic news that Al-Hakam had died:

At this he [Ziryab] considered turning back to Africa, but Mansur, the Jewish singer sent by Al-Hakam to meet Ziryab, persuaded him to remain and wait for word from Abdu'r-Rahman II, son and successor of the dead monarch. The Jewish singer wrote to Abdu'r-Rahman, telling of the occurrence, and shortly after Ziryab himself received a letter from the monarch inviting him to Cordoba and expressing his pleasure in the expectation of his presence" (Ribera, 1929, p. 102).

The successor Abd al-Rahman II turned out to be a great patron of cultural development and Ziryab was listened to and his ideas on reforms were implemented. Abd al-Rahman II and Ziryab became lifelong friends and their cultural contribution is so ubiquitously in the mores of daily life even today that it has become invisible.

Contributions

Music

Ziryab advanced and developed the Oud, the predecessor of lute and guitar. He added a fifth pair of strings and dyed the four strings a different color to symbolize the humors, the elements, and the fifth string to represent the ether, the soul. For greater sensitivity to the instrument and greater dexterity and precision of playing, he also introduced the use of a quill instead of a wooden pick.

The music based on his deeply considered and communicable style became a mode of Iberian and North African Music for generations. An example is nawba, an ensemble style where a larger group of people take turns singing individually. Cordoba became the place of one of the first schools of music initiated by Ziryab, with equal training for male and female students.

Model courtier

Ziryab must have been from an early age, a model courtier brought up with a profound knowledge of etiquette, unspoken innuendos of court interactions and ways of elegance. He deeply understood the use of artifice and stylization to bring out natural beauty in everyone. His early education and context of life must have provided an understanding of the mores of musicians behind the scene. At some periods in history and when they are very young, boys are allowed and nurtured in women's quarters until they are of a certain age. Ziryab must have seen elaborate and sophisticated ways of dressing, personal hygiene and body beatification pro-

cesses of court singers that gave him grounding for his later involvement and revolutionizing the fashion of his day and enabled him to be a trusted and consulted arbiter of taste.

The list of his innovations is staggering and the fact that they are not only for the aristocrats but could be adopted inter-culturally by a wide spectrum of people and implemented within their means, are the achievements of cosmopolitan urbanity of Umayyad Spain unparalleled in most of Europe at that time. The portal list of his innovations parallel to music.

Fashion:

- Brought the flattering and opulent dressing of urban Baghdad, Damascus and the Orient to Iberia.
- Launched different clothing for mornings, afternoons and evenings and for winter and summer.
- Introduced winter clothing usually in dark colors, created from warm cottons, wool and velvet that he brought to Spain in contrast with summer clothing fashioned out of cotton, silk and flax in lighter, cooler materials and brighter colors.
- Set up a fashion and textile industry producing colored striped fabric and coats of transparent fabric, and introduced bleached white clothing.

Grooming

- Revolutionized hair cut with a fringe down to eyebrows, cut straight across the forehead, the ears and neck uncovered, considered a bit risqué. (Before this men and women wore long hair that hung loose to their shoulders, parted in the middle)
- Opened beauty parlor and cosmetology schools teaching the shaping of eyebrows and the use of depilatories for removing body hair, and he introduced new perfumes and cosmetics.
- Introduced the use of fragrant oils and salt to maintain healthy and shiny hair condition
- He also advocated morning and evening baths and emphasized the importance of personal hygiene.
- He made shaving for men widespread.
- Invented a new type of deodorant.
- Invented an early toothpaste

Food

- Introduced the Tablecloth and brought many dishes from Persia, Baghdad, Damascus and created a new menu.
- Revolutionized the local cuisine and table procedures, by initiating the three-course meal of soup, the main course, dessert and introduced new fruits, vegetables and herbs. He also introduced the use of glassware in-

stead of metal goblets. Introduced New Year celebrations into Spain that spread over time through Europe based on the Persian festival of Nouroz.

The Role

It is rare in history that an adviser was listened to that extent and given a chance to implement so many well considered ideas in multiple fields. It is so rare for a patron to develop a deep working, life long relationship with an adviser. It seems that Zirjab's internal grace and wisdom guided him to never overstep the delicate boundaries of power and friendship. Al-Hakam II and Ziriyab's partnership created a living, inspiring cultural nexus that made Al-Andaluse and Cordoba the intellectual and artistic center of their time, 8th and 9th century Iberia and that continue to this day.

7. St Francis of Assisi, 1182-1226

Journeys from Assisi to Damascus, Damietta and the Holy Land

The story of St. Francis is well-known, a twelfth century youth, son of a wealthy cloth merchant adorned in finery and singing troubadour songs as he led his comrades of the town of Assisi in Duchy of Umbria, now part of united Italy. After a crisis of meaning and a deep religious experience, he began to lead a life of poverty and renunciation that disturbed and worried his father. After public rejection of his father's values and their mutual rejection of each other, Francis became a wandering monk unattached to any order or monastery. He lived mostly in the country restoring an old church as his inner voice prompted him, soon a few others joined him. As a reformer and independent ascetic, he narrowly received the recognition of the Pope as he formed a new order of Little Brothers, now known as Franciscans, pledged to poverty and helping others. His official biographies in the west describe his eastward journeys as a means of seeking martyrdom. In Asia Minor among non-Christians there is an apocryphal story that he met Shams Tabriz, teacher of mystic and poet Rumi, in Damascus and played chess with him. Two years after his death he was canonized as a saint and is now one of two patron saints of Italy. His order produced many missionaries.

The story of St Francis is loved and deeply integrated into European consciousness and identity. There is nothing more Italian and Catholic than the genuine, humble saint talking to animals and being kind to plain folks. His example, commitment and courage have brought freshness and reform after twelve centuries of the establishment of the Christian church. There are some aspects of his story that make more sense if they are viewed in the context of Mediterranean history and intercultural exchanges. Opening his story to a critical understanding of his time will in no way diminish his contribution and importance as one of the genuine proponents of a lived religious experience and as the patron saints of the poor and disenfranchised. Introducing known facts from history, attitudes toward strangers

by non-Europeans and mores of his time, may make the appreciation of his contribution even more universal.

St. Francis was a bicultural and bilingual child. He was half Umbrian and Half Occitan, his mother was Occitan, a French-Italian identity would be a nineteenth-century concept. St. Francis of Assisi as a young man was one of today's best-known Italian Troubadours. This period of his life is portrayed as lighthearted, trivial and worldly. This disconnect between youthful St. Francis and the religious St. Francis is a reflection of the European disconnect to its own earlier medieval history. Troubadour lore and ethos were a profound and symbolic expression where the sacred is expressed through secular love allegory. Persian and Arab poetry that bloomed in medieval Iberia is full of this allegorical and implied meaning. The troubadours became the main communication vehicle celebrating values of the Occitan culture that flourished before being crushed by the Albigensian Crusade and its territories annexed by neighboring kings. There is a great difference between being a troubadour when that culture was flourishing and being an unrepentant troubadour and dissident when that culture was crushed.

Occitan was the *lingua franca*, the shared international language of the Troubadours. In some ways it is closer to Galician and Portuguese than to French as we know it today. (That may be one of the reasons why the patron and protector of Troubadours and musicians, the neighboring Spanish king, Alfonso X, favored Galician as a language of poetry in his Spanish territories). And of course Guillaume d'Aquitaine, the recognized proto-Troubadour, wrote in Occitan. The Provençal Occitan and Iberian Catalan are almost dialects of the same language, the late Latin. Originally "Lingua Franca" (also known as Sabir) referred to a mix of mostly vernacular Latin, that became Italian, with a broad vocabulary drawn from Persian, Occitan/Catalan dialects, Greek and Arabic. Lingua Franca literally means 'Frankish language'. This originated from the Arabic custom of referring to all Europeans as Franks (Batzarov, 2000).

St. Francis' grounding and learning, acquired mastery of poetry and music as well as cultivated dexterity and understanding of Troubadour lore, was a significant building block in preparing him for his vocation and calling. St. Francis' father – a cultured and well-connected merchant of linen – called him Francis after the Franks, people of Occitan whose culture, refinement and courtly values he must have adored. The Occitan coast was the lucky recipient of the westward Mediterranean current that received the ships and goods from the east and ever since ancient and even prehistoric times, had ports that re-organized the received cargo for its inland journey up north to the Atlantic coast. Brocades, damasks and silks from the east traded for wool from Scotland and England and European flax. The merchant's forms of greeting, respect and etiquettes of safe conduct must have been known to San Francis since he was a child as he was trained in his family's business. This knowledge probably helped him travel through Spain and the east.

If we put his possible knowledge of traveling etiquette next to the Islamic general acceptance of three Abrahamic religions and respect for priest, monks and

wandering mendicant, we can see a clearer picture of St. Francis' historic encounter with Sultan Saladin. Francis and another friar had audience with the Sultan possibly during a relatively short period, a month long ceasefire at the siege of Damietta in Egypt. Posthumous biographical description of St. Francis being torched and beaten by "savage Saracens" obscures the Sultan's civilized and tolerant reception, dialogue and permission to visit the fledgling Franciscan mission in the Holy Land. Any territorial infringement by uninvited strangers provoked suspicion and questioning, particularly if the crossing was in wartime. His biographer's detachment from St. Francis' equivalent of "illegal immigration" obscures the critical understanding of mores, etiquettes, sensibilities and riches of Mediterranean intercultural exchanges. Tolerance and flow seem so much closer to St. Francis' message, as according to some biographers, he tried to dissuade Crusaders from attacking upon his return.

St Francis' contribution

This paper does not question the validity, simplicity and sincerity of St. Francis' contribution. The phases and reality of religious experience is outside the domain of our paper and our approach. Viewing his life from the point of view of Mediterranean cultural currents validates and makes credible his contribution to an ecumenical, interfaith and secular audience and scholarship.

8. Ibn Arabi from Seville to Damascus

The reason we follow the description of Ziryab's great and inspiring journey westward from Bagdad to Cordoba with a brief account of Ibn Arabi's influential passage eastward from Seville to Damascus, is to give a sense of the comparable wave of cultural influences from west to east in the proceeding centuries after Ziryab. This is as a way to set up some observable perimeters in studying influences and counter-influences and helps us understand how intangible heritage can play a role in giving a greater glimpse and understanding of history.

Culturally and in general we are still more or less under a nineteenth century model that defines Middle Ages as Dark Ages. Current interest internationally of the Mediterranean Studies' in intercultural and comparative inquiry is opening scholarship to areas previously unarticulated. Bringing some elements of intangible heritage and shared motifs into an overview of Ibn Arabi's life and work may also enrich our understanding of Mediterranean cultural history.

Ibn Arabi early years

Born in Murcia in Moorish Spain, Ibn Arabi (1165-1240) moved to Seville with his family when he was a young boy. Like Cordoba, Seville was one of the cultural centers of Islamic Spain. Ibn Arabi's schooling in Qur'an and other basic elements of Islamic education began in Seville probably at the age of 7 or 8. Ibn Arabi's

father recognized his son's intellectual abilities and sent him to leading clerics and jurists for training.

An important element of this education was the study of Hadith, large collections of sayings, implied and stated meaning of the Prophet Mohamed used in Islamic jurisprudence, clerical interpretations and religious discussions. This was a required learning for anyone aspiring to public office, religious or scholarly vocation. The credentials are acquired by being accepted, apprenticed and trained by respected and established practitioners. This apprenticeship also trained the manners and the behavior of the learned man acquiring body language as well as deeper attitudes to religious practices by assimilating the examples of the elders. Not dissimilar to musicians learning a large amount of traditional material by heart and learning the elusive art of interpretation and creative response from living teachers.

This synergy of intellectual and bodily engagement is very important in understanding the education and bearing of any public figures or courtiers in pre-industrial times and particularly in the East and the Mediterranean. Out of this learning model emerges Ibn Arabi whose contemplative and articulating gifts have been recognized early.

Ibn Arabi wrote in his dictionary of Andalusian teachers and mystics, *Al-Durrat Al-Fakhira*, about two of his women teachers Shams of Marchena, and Fatima of Cordoba. This association seemed to have happened when he was 16 or 17 when his grounding in scripture and commentary was in advance states of accomplishment. This association with practicing mystics along with his own abilities probably created a fork in the road that led him from potentially training for public office to becoming a practicing mystic, teacher and prolific writer about religious experience.

C. A. Helminski (1994) in her article on women mystics in Islam quotes R.W.J. Austin's translation of Ibn Arabi's (1988) recounting his connection with one of his early significant teachers :

I served as a disciple [to] one of the lovers of God, a gnostic, a lady of Seville called Fatimah bint Ibn al-Muthanna of Cordova. I served her for several years, she being over ninety-five years of age... She used to play on the tambourine and show great pleasure in it. [...] With my own hands I built for her a hut of reeds as high as she, in which she lived until she died. She used to say to me, 'I am your spiritual mother and the light of your earthly mother (Ibn Arabi, 1988, pp. 25-26)

The quote is very important as it portrays the rich relational aspects of discipleship. The knowledge is not transmitted only through reading of scriptures, study, memorizing and possible discussions but also by rising to occasion and attending to daily needs of situations for and with a teacher. Also of interest in this quote is the translator's choice to use the term Gnostic in describing Fatima. The entire Andalusian and neighboring Provençal cultures gave space for adoption and development of expressions of search, attitude or methodology for direct experience, Christian Cathars, Jewish Cabalists and Islamic Sufis seem to have some Gnostic element in their processes. This is the climate in which Ibn Arabi grew up and matured as a seeker, writer and teacher.

The second half of his education took place among spiritual and mystic confraternities in North Africa. The gravitational pull of religious confraternities of North Africa is interesting in connection to the example of the journeys of Francis of Assisi and Ramon Llull latter in this paper. The cultural significance of oral traditions in general will be of interest when we look at Neo-Platonic thought, schools and transmissions surrounding the example of Georgius Gemistus Pletho's life work. As cultural historians of ideas and intangible heritage, we straddled the difficulty of basing our reconstructions on very minimal evidence and writing about phenomenon that provides little documentation about their processes of transmission, and the official views that look at them as heresies, deviances, marginal occurrences or historically unimportant. In view of this we present a brief summary of Ibn Arabi's inner and outer journey and conclude this section with glimpses of Iberian culture within four hundred years with his life more or less in the middle of it.

Advising, wandering, writing, teaching

After receiving a mantle from his North African teachers and a brief return to his native city and districts of his upbringing, Ibn Arabi at the age of thirty-five embarked on the hajj, the pilgrimage to Mecca. On the way to Mecca and afterwards his advice, or just conversation was sought by a number of courts, dignitaries and rulers. Once he reached Mecca he lived there for three years. After that period he headed to Anatolia with his traveling companions and disciples. This sojourn lasted almost forty years, interrupted by a number of subsequent pilgrimages to Mecca. As his reputation grew and his interpretations caught the imagination of his contemporaries in the last 17 years of his life, he settled in Damascus.

Rich cultural context

As we touched upon earlier, the entire Andalusian and neighboring Provençal cultures gave space for adoption and development of some form of search, attitude or methodology for direct experience, Christian Cathars, Jewish Kabbalist and Islamic Sufis seem to have some Gnostic element in their processes. Once again we emphasize the richness and the crosscurrents of Al-Andalus in which Ibn Arabi grew up and matured as a seeker, writer and teacher.

William C. Chittick, one of the world's experts and translator of Ibn Arabi has this intriguing paragraph in his web article on the life and work of Ibn Arabi:

In fact, his earliest encounter with the "Men of the Unseen World" (*rijāl al-ghayb*) was with Jesus, as he states repeatedly, and his first teacher on the path to God, Abu'l-Abbās al-Uryabī, was dominated by Christ's spiritual influence. Ibn `Arabī considered Jesus the "Seal of Universal Sanctity". He himself, at least in certain passages, claimed to be the "Seal of the Particular, Muhammadan Sanctity", so his early encounter with Jesus certainly suggests something about how he understood his own calling (Ibn Arabi, 1988).

The Christian reference is fully integrated in Ibn Arabi's reflection on succession of prophets that is part of the Quran and traditional commentaries. The quote is never the less interesting from a point of view of comparative cultural history. Moorish Spain and adjacent Occitan were a breeding ground of a whole array of independent thought considered heretical within the mainstream of canonized religions. Even Ibn Arabi's deep commitment, understanding and interpretation of Islamic Revelation are not universally accepted. Ibn Arabi's possible indirect influences on Christian and Kabbalistic thought still remain mostly unexplored.

A century prior to Ibn Arabi's time, the life and work of Ibn Hazm (994-1064) is an example of possible Iberian and Provençal inspirational flow. He was an Iberian proto-troubadour, who wrote primarily about law and theology and whose books were burned in public. Ibn Hazm is also the author of *The Ring of the Dove*. This work is a treatise about love composed in the Arabic-Persian mode of elegant writing. Translator A. J. Arberry describes Ibn Hazm's work as a systematic treatment of love and affection, combining metaphysics, social commentary and psychology. Troubadours of Provence on the other side of the Pyrenees continued Ibn Hazm's poetic tone and ideas later, a tradition that began in the 11th century.

Within this geography on both sides of the Pyrenees, facing the Mediterranean, the cultural diversity, trade and commerce flourished. M. R. Menocal (2002) in her book *Ornament of the World* helps articulate the parallel genesis of Jewish Kabbalists and Albigensian belief system:

It [the Occitan territory] was also the seat of the Jewish mystics and esotericists we call kabbalist. Culturally they were much like their Andalusian brethren, but spiritually they were at odds with the Andalusians' intellectual and philosophical visions of faith. This "land of yes" seemed to specialize in nay-saying, and it was also the breeding ground of the Cathar, or Albigensian, heresy, the resolutely Manichean "Church of the Purified" that Rome began to come down on heavily by the mid-twelfth century (Menocal, 2002, p. 221).

The mystical schools and co-fraternities, grounded in Islam but looking for direct experience of the transcendent reality (of which Ibn Arabi was a numinous proponent) are often marginalized by the established currents of religious interpretation of their time. Ibn Arabi's work is an example of a transmission of knowledge that is not an ornament or a badge of office or status but a communicable insight beyond formal elaborations. This fresh insight is the cultural wave from west to east that Ibn Arabi brought through North Africa, Egypt, Arabia and Anatolia to Damascus.

9. Ramon Llull, 1232-1315, philosopher

Ramon Llull's life journey revolved around the West Mediterranean. He evolved from troubadour to spontaneous mystic, then embraced the Lay Franciscan Order and ultimately became a missionary and a religious and practical philosopher. Ancient

Phoenician ports, routes and domains that were later echoed in the Aragonese dominance of western Mediterranean are trajectories of Llull's crisscrossing from Balearic Islands to Tunisia and North Africa, Italy and the Iberian Peninsula.

In the aftermath of the Albigian Crusade, the vacuum created by a distraction of Languedoc saw the rise of James I the Conqueror, King of Aragon. He established Aragonese supremacy of the Western Mediterranean and codified it in *Consulat de Mar*, a document that empowered Mediterranean trade centered in Barcelona and his expanding domain. His kingdom grew from Catalan territories east to Balearic Islands, north to Languedoc and south to Valencia. At the Court of James I in Majorca, the largest of the Balearic Islands, Ramon Llull was born into the family of courtiers.

He showed an early aptitude for learning and was exposed, due to living at the Royal court, to all the cultural currents of his day. Being a Troubadour and versed in courtly manners and lore were expected and natural for a young courtier. The court was a place of coming and going of envoys, musicians, astronomers/astrologers, mathematicians, law experts, medics, charlatans and the wise. Arabic was one of the languages spoken at the court along with Sabir, the *Lingua Franca* of the day and Catalan/Occitan. Latin came with Roman Law, rhetoric and ecclesiastical matters. Greek was attempted in connection to Aristotle and a fledgling interest in Neo-Platonism that was also available, in part, in Arabic. Ramon Llull first became the tutor to the king's son, the future Majorcan King James II and then advanced to be his Chief Steward, the administrative head of the household.

Ramon Llull was born eight years before Ibn Arabi died, six years after the death of St. Francis and four years after The Albigian or Cathar Crusade crushed Occitan. Llull was forty when Georgius Gemistus Pletho was born and sixty when Gemistus had completed his grounding education. There was not a direct communication or influence between the two. These comparisons are just to contextualize the timeline to give a sense of the general period of this paper, inadvertent overlap, shared and evolving historic climate.

Through a series of visions and epiphanies he became a religious person and joined the Franciscan order as lay brother as he was married and had two sons.

Ars Magna is Llull's life work in many volumes including *The Book of the Ascent and Descent of the Intellect* and *The Tree of Knowledge* containing the imagery of annotated trees and ladders or climbing steps. Another recurring set of images is a series of circles or seals describing divine attitudes. Llull advocated and developed a simplification of all knowledge into nine divine primordial attributes: goodness, greatness, eternity, power, wisdom, will, virtue, truth and glory.

It is an open question about a possible direct influence on Llull's work from *Za'irajah*, a technique practiced in the Arab speaking world of his time. *Za'irajah* was a method of divining answers by mapping out connections existing between the letters used in a question, often expressed as a circular diagram.

North African Muslim thinker and historian of Iberian descent, Ibn Khaldun (1332-1406) writes in his encyclopedic *The Muqaddimah* about *Za'irajah* as «a

subdivision of the science of letter magic» describing it as «an unfathomable subject with innumerable problems» (Ibn Khaldun, *The Muqaddimah*). He continues with this observation:

Ibn al-'Arabi, and others in their wake wrote numerous works on it. These authors assume that the result and fruit of letter magic is that the divine souls are active in the world of nature by means of the beautiful names of God and the divine expressions that originate from the letters comprising the secrets that are alive in the created things.

Frances A. Yates (1966) in her ground-braking book *Art of Memory* writes in a chapter titled *Lullisam as an art of memory*:

The Names of God are fundamental in Judaism, and particularly to the type of Jewish mysticism known as the Cabala. Spanish Jews contemporary with Lull [Llull] were meditating with particular intensity on the Names of God under the influence of Cabala, the *Zohar* was written in Spain in Lull's time. The Sephiroth of the Cabala are really Divine Names as creative principles. The sacred Hebrew alphabet is, mystically speaking, supposed to contain all the Names of God. A form of Cabalist meditation on the letters of the Hebrew alphabet involved combining them and recombining them to form the Names of God (pp. 178-179).

It is important to remember here the centrality of the concept of the 99 Names of God in Islam. The names are not numbered allowing for combining and equal emphasis. In the Qur'an and related literature, the Names of God as adjectives, word constructs, or otherwise, exceed 99. 99 Names of God in Islam has similarities with the Zoroastrian evocation of hundred and one divine names. F. A. Yates write about Llull's possible inspiration for the names:

Mohemmedanism, particularly in its mystical form, Sufism, also attaches great importance to meditating on the Names of God. This has been particularly developed by the Sufi mystic, Mohidin, the influence of whom on Llull has been suggested (Yates, 1966, p. 179).

Llull became a pioneer of later periods of western European attitudes toward other religions and representations of transcendence. He was advocating the conversion of all Jews and Muslims to Christianity heralding the expelling legislations and attitudes. He deeply believed that the pure logic of his method would make for a peaceful transition and hoped to create a system that was full proof. Using logic as means of conversion to replace the Arab *Convivenca* that was based, as we mentioned before, on the cohabitation of multiple religions. He was also the predecessor of scientific detachment and reductionism and is recognized today as a forerunner of information - computer science and systems logic. In the interest of bringing out the comparative consciousness of Mediterranean coexistence, we are not casting a judgment on the validity of Ramon Llull's contribution. Our continuous effort is to contextualize the examples into a broader historical context.

F. A. Yates continues in her chapter *Lullisam as an art of memory*:

The story told in the contemporary life of Llull of the alarming vision that had in a Dominican church in which a voice told him that only in the Order of Preachers would he find salvation. But to enter the Order of Preachers he must abandon his Art. He made the bold decision to save the art at a possible expense of his soul 'choosing rather that he himself should be damned than that his art, whereby many might be saved, should be lost (Yates, 1966, p. 193).

Llull's responses to the vision set him apart from the Mediterranean mystics and religious thinkers and their relationship to knowledge and experience. The decision not to abandon his system makes him in a way closer in temperament to scientist like Galileo, Copernicus Kepler of the sixteenth century or eighteenth century philosophers like Goethe and Leibniz (who was influenced by Llull's work).

Identified with one's work and the belief in posterity, valuing and validating it, is different from Prophet Mohamed or St. Francis serving the revelation received with every atom of their being. Attempting to articulate this difference sets the stage for looking at George Gemistus Plathon as a quintessentially Eastern and Mediterranean response to receiving and transmitting knowledge.

10. Georgius Gemistus Pletho (1355-1454)

The reflections in this chapter on the elusive, almost hidden history of the life work of Georgius Gemistus *Pletho* are mainly based on two sources. The first source, *Georgius Gemistus Pletho- The Last of the Hellenes* by C. M. Woodhouse published in 1986 by Oxford University Press, is the detailed study of most of the surviving documents written by Gemistus and his immediate circle of contemporaries. The other source is the ongoing study and collection of comparative examples of oral traditions by the author of this paper and the Artship Foundation. This includes observing examples of skills training, memory systems and ways of tallying that are not written down. This inter-cultural study looks at surviving traditional and contemporary on-the-job apprenticeship education. C. M. Woodhouse in his book on Gemistus writes about the philosophy omissions that the renowned Byzantine teacher of Platonism left out from his excerpts and summaries:

In the higher studies, especially philosophy, he preferred oral teaching. He [Gemistus Pletho] liked to emphasize that Plato and the Pythagoreans distrusted the written word as the means of communicating their most important ideas (Woodhouse, 1986).

So through looking at C. M. Woodhouse's meticulously researched findings, we bring our research to fill some gaps with open questions and tentative hypotheses about transmitting of insight and distilling through means other than writing. Oral traditions were the main instrument for passing knowledge and training dexterity of the body or the mind before writing was invented. It persists throughout history to this day, in different regions and for a different purpose. Oral transmission is ever-present in the Mediterranean history, for example seafaring skills and knowledge are mostly communicated in direct training particularly among fisherman.

Early education and youthful studies

George Gemistus was born into a family of jurists that was close to the Byzantine Court at Constantinople, either as advisers, courtiers or cherished guests. As a son of a prominent family he was exposed to the finest cultural achievements of his time and received a classical education and general education of quality. His instinct for learning, family support, independent spirit, deep inborn sense of dignity and discretion led him to cultural and cosmopolitan places and cities in search of knowledge and meeting the wise people of his time. He traveled to Cairo, Baghdad, East Mediterranean islands and territories with possible learning communities like Cyprus, Anatolia and Palestine. Adrianopolis seems to be a place where he studied under a teacher. At the time of Gemistus, Adrianople in Threce was the cosmopolitan capital of the Ottoman state. Threce, today East Thrace or European Turkey is bordering with Greece and Bulgaria, separated by the Dardanelles from Turkey of Asia Minor.

According to C. M. Woodhouse, the most careful of the sources on Gemistus, it appears in indirect references that he studied with the obscure philosopher Elissaeus. C. M. Woodhouse critically evaluates admissible references from written sources and gives glimpses of Elissaeus. Summarized here, Elissaeus must have been a trained Greek philosophy teacher, also connected to Zoroastrianism of Persia, an interpreter of Islamic thinkers like Averroes, and of Jewish origin and learning. Elissaeus' mix of interests, skills and attention to the diversity of traditions reflects a more Arabic intellectual climate with the Mediterranean richness of influences and counter influences than the Byzantine dogmatic views of what is pure and what is heretical and corrupted knowledge. Elissaeus must have been a trained Platonist who carried the teaching and methodology of transmutation of knowledge of the Platonic Academy ever since its closing in the fifth century AD went underground.

Before we evaluate the ramifications of this teacher-student relationship of Plathon-Elissaeus and its' influences on the Italian Renaissance and that particular knowledge itinerary, let us look briefly at some cultural centers of the east Mediterranean of their time and the time of Abbasids.

Baghdad

Harun al-Rashid (we mentioned earlier in the section on the musician Ziryab) knew that a flourishing empire needs to encourage and legislate for art, culture, learning and commerce. He and particularly his son al-Ma'mun in the 9th century instigated among many initiatives, The House of Wisdom, a library and translation institute in Baghdad.

Both Umayyad Cordoba and Abbasid Baghdad were the cultural capitals of the Islamic world from the 9th to 13th centuries. Although rivals and at a great geographic distance from each other, the flow of ideas, scientific and other research was carried by itinerant scholars, mystics, experts, advisers and artist. Baghdad of the al-Ma'mun region fostered many disciplines. Today we know about develop-

ments in the science of hydraulics, time keeping and navigation, astronomy/astrology, alchemy/chemistry, zoology, botany, medical botany, medicine and mathematics with emergent algebra. This includes collections of Persian, Hindu and Hebrew scriptures and translation of Greek manuscripts, summaries and comments on Plato, Aristotle, Pythagoras, Plotinus and probably a number of others.

Under Abbasid Dynasty, Baghdad was a truly cosmopolitan capital with a population of over a million, abundant in diversity of people and religions, material wealth, intellectual development, cultural and artistic reaches.

Cairo and Adrianople

Cairo gained cultural importance through the complex tangles and battles of numerous interests throughout the late middle ages. Its prominence was aided by Abbasid Caliphate dynastic infighting, Mamluk Turkic's Military successes, Mongol invasions and ambitions and Christian Crusader Claims. Also the rise of the Ottoman and shrinking of the Byzantine Empires witnessed development of cultural and learning institutions that attempted to rival Baghdad. Like Cairo for the Mamluks, Adrianople for the Ottoman state developed into a significant cultural and learning center. Adrianople was in the late 14th century the capital of the Ottoman state. Gemistus went to Adrianople when he was twenty approximately in 1380.

Discrete Learning Containers

The thinkers, teachers, students, and devotees traveled and intentionally followed or looked for their own networks of religious, ethnic, learning or mystic communities, libraries and schools. After the destruction and burning of Alexandrian Library in the 5th century AD the dispersed scholars formed formal and informal fraternities that kept some of Hellenic and other traditions alive, evolving and sometimes cross-pollinating. Just like Ibn Arabi who found the networks of his tradition and beliefs traveling from Spain to Anatolia via North Africa, so did young Gemistus crisscross the Eastern Mediterranean in search of deepening and broadening his philosophical, legal and historic interests. This culminated in Gemistus finding or being found by a living teacher capable of transmitting.

Ammonius - Platonist Teacher

In Alexandria of the 3rd century BC was the home of a philosophy school held by the almost anonymous Ammonius Saccas, *sakkophoros* – sacks bearer. He did not document any of his teaching or write down his ideas and encouraged his pupils to do the same. The known students of Ammonius were Plotinus, Origen and Herrenius who must have, according to tradition, accepted the requirement of nothing being written down. It was only when Herrenius, probably departing from the school, wrote about its ideas that Plotinus and Origen responded in writing to correct partial and misleading representation. It is with thanks to this rising to the occasion that we have the significant writings of Plotinus.

Ilija Savic, colleague of the author of this paper, in researching Porphyry, early Neo-Platonist and traces of Orphic Mysteries for his doctoral thesis, before his untimely death, was of the opinion that neither Clement of Alexandria or Athenagoras were fully trained Orphic initiates. He shared this view with colleagues that prior to converting to Christianity, he must have had only a rudimentary training in the mysteries and denounced them because of their limited knowledge. It appears that facts about Orphic, Elysian or any other mystery processes came from students that have broken the training either voluntarily or have been asked to leave.

Another example of a complex relationship of a Platonic School to the surrounding culture is, the life and work of Hypatia in the fifth century, before she was brutally assassinated by a Byzantine appointed bishop. She held a Platonic Academy at Alexandria. She wrote on mathematics, astronomy and music but did not write about her teachings of philosophy and methods of transmission. Destruction of Hypatia and the subsequent burning of the library saw dispersion of Hellenic, Jewish and Egyptian/African scholars, writers, translators and scientists into the geographic areas of the Fertile Crescent. An overlooked fact of cultural history is that the Old Testament as we know it was compiled at the Alexandrian Library by a collegium of probably eighty Rabbis and most likely first drafted in Greek, which points to the multiple cultural strands nurtured there.

G. N. Atiyeh (1998) in his paper gives insight into the Iberian mystic and teacher Ibn Masarra born in «883 AD in Cordoba, and died in 931AD in a hermitage he had founded for his friends and disciples in the Sierra of Cordoba». G. N. Atiyeh writes:

M. Asín Palacios, the Spanish scholar who first reconstructed an integral account of Ibn Masarra's life and thought, concluded that he was the first Andalusian to structure Spanish Islamic philosophy (*hikma*) and that he conveyed his doctrines in a series of *batini* (inward) esoteric images and symbols (Asín Palacios, 1972). The centrepiece of Asín's thesis, however, was the elaboration of a whole theory of Ibn Masarra's inspiration from a pseudo-Empedocles, who had developed a peculiar form of Platoian ideas on the One and the five eternal substances of Primal Matter, Intellect, Soul, Nature and Secondary Matter. According to Asín, Ibn Masarra was the founder of a philosophical-mystical school which influenced Jewish, Christian and Muslim medieval philosophers. Andalusian Sufism from Isma'il al-Ru'ayni (d. ah 555/ad 1268) to Ibn al-'Arabi by way of Ibn al-'Arif (d. ah 536/ad 1141) sprang from the Masarra school (Atiyeh, 1998).

G. N. Atiyeh in the following passage points to a perpetual strife and danger Neo-Platonist thought encounters under any system.

His success came from a Socratic style of pedagogy as well as a charismatic personality and skill in communication. After his death the jurists carried out a veritable persecution of his disciples; who had formed themselves into an ascetic order, the Masarriya, in Cordoba and later in Almeria (Atiyeh, 1998).

Before we return to Gemistus Plathon's and Elissaeus' teacher-student relationship let us remember Socrates for the moment. The barefooted teacher and mystic Socrates, often on a way to attending to matters of daily life, stopped in the streets and porticos to commune with a world of ideas. An elderly impoverished thinker, he was accused of corrupting youth and executed in the democratic Athens of the

5th century BC. He did not write any of his ideas and teachings. What is it that makes him and other teachers of philosophical austerity and rigor so unacceptable to the authorities? Plato also never expounded directly on his theories but puts them in the mouth of the characters of his dialogues allowing for contrasting and inconclusive views.

It appears that in looking at a number of instances inter-culturally, that a training of philosophers with an aspiration to some direct knowledge of transcendent reality demanded a rigorous training not only of the intellect but also of the being of the aspirant. As cultural historians we do not advocate any outcome but the fact that humanity in all its cultures has had methodologies for transcendence is of interest here. Neoplatonic schools seem to offer such training, the traces of its intangible itineraries crisscrossing the Mediterranean can be seen in many geographic areas and in all of the regional and diverse religious traditions. Gemistus Plathon belongs to that culture of highly trained philosophy teachers of the Mediterranean.

We learn mostly about Gemistus' training from a vigorous detractor, a lifelong enemy and his ex-student George Scholarios who became Patriarch of Constantinople under the new name of Gennadios. Before we analyze Scholarios' text on Plathon's education and training, let's look at some general characteristics of direct learning. To remain comparative and open in the study of methodologies of direct learning from a teacher, we based this draft of the stages on scant documentary evidence, folklore, training of musicians, artist and craftsmen in traditional societies, oral reminiscences, post training diaries, anthropological writing and Pythagorean, Platonic, Neoplatonic, Hermetic and Cabalist training fragments. Gemistos Plethon must have gone through the same process resembling phases listed below.

- Natural aptitude and schooling
- Years of physiological destitution and search (regardless of outer circumstances)
- Signs, recommendation, hearsay about a teacher or a school
- Meeting of the teacher and student
- Testing of the student's resolve
- Preliminary acceptance into some form of apprenticeship
- Renunciation, service, daily practice and learning
- First responsibilities, privations and isolation as test of quality of being
- Deeper internal acceptance, shedding aspects of conditioning
- Rejection from the school/teacher as second larger test of the resolve
- Bewilderment and crisis, temptations of power
- Transpersonal merging into the essence of the school or teaching
- Specialization and Life Skills, profession
- Fully integrated as a proponent / carrier of a particular tradition and becoming its teacher

C. M. Woodhouse meticulously presents the case of Gemistos' ex-pupil Scholarios, later renamed Gennadios as Patriarch of Constantinople. After the fall of Constantinople in 1453 and death of Gemistus in 1454, Scholarios posthumously was seeking to justify his burning of Gemistos' advice to the princes in the *Book of Laws*. To explain the genesis of this Gemistos' last work and to Scholarios most heretical work, the manuscript of which he had received from Theodore's sister of Despot of Mistra, into whose hands it had gone when Gemistus died. Scholarios' denouncement is our source for following Gemistos' path of learning and the multiple influences he absorbed. C. M. Woodhouse writes:

Scholarios detected the origin of Gemistos' heresies in his education, which he described in the following terms: «Before he had acquired the maturity of reason and education and the capacity of judgment in such matters – or rather, before he had even devoted himself to acquiring them – he was so dominated by Hellenic ideas that he took little trouble about learning traditional Christianity, apart from the most superficial aspects» (Woodhouse, 1986, 24).

Gemistos shows natural aptitude for learning and his schooling took place between the Imperial Court, the Byzantine legal system, the Orthodox Church and private tutors and he probably excels in the necessary grounding available at his time in Constantinople.

In reality it was not for the sake of the Greek language, like all Christians, that he read and studied Greek literature – first the poets and then the philosophers – but in order to associate himself with them; and so in fact he did, as we know for certain that many who knew him in his youth (Woodhouse, 1986).

Years of physiological destitution and search (regardless of outer circumstances) in a state of *having no peers* happened to many gifted children and youth throughout history. It is a period that teaches them to stand-alone, to have intellectual courage.

It was natural in the case of a man under such influence, in the absence of divine grace that through the demons with whom he associated there should have come a tendency towards an ineradicable adherence to error, as happened to Julian and many other apostates (Woodhouse, 1986).

There are many stories in history and folklore of how people found signs, responded to recommendation, or went to search after hearing about a teacher or a school. This seems to be part of many oral traditions and a numinous, fertilizing moment in an otherwise rigorous process of testing of the student's resolve. We glean something of this from Gemistos' conduct as a teacher from his students who had stamina and were encouraged to stay and complete the training.

The climax of his apostasy came later under the influence of a certain Jew with whom he studied, attracted by his skill as an interpreter of Aristotle. This Jew was an adherent of Averroes and other Persian and Arabic interpreters of Aristotle's works, which the Jews had translated into their own language, but he paid little regard to Moses or the beliefs and observances which the Jews received from him (Woodhouse, 1986).

From this text above we can approximate that Gemistus was accepted into a necessary form of full apprenticeship that demanded renunciation, service, daily practice, learning diligence and probably practical chores. Scholarios' denouncement also points not only to the rich inter-cultural intellectual influences but also indirectly to the father aspect of training like deputized responsibilities, contained privations and isolation as test of quality of being.

This man also expounded to Gemistos the doctrines of Zoroaster and others. He was ostensibly a Jew but in fact a Hellenist (pagan). Gemistos stayed with him for a long time, not only as a pupil but also in his service, living at his expense, for he was one of the most influential men of the court of these barbarians. His name was Elissaeus. So Gemistos ended up as he did (Woodhouse, 1986).

This negative passage points to a phase of training when unity of *shared tradition* among practitioners is stronger than duality of teacher-student. It probably comes after the hardest test of being rejected by the school or teacher leading to bearing bewilderment and crisis. It is a phase that very few survive and it forms the end of training for many aspirants. Scholarios probably never past this one as part of the bewilderment phase is a test of temptations of power, summarized in saying: if you want to test someone give them power.

He tried to conceal his true character, but was unable to do so when he sought to implant his ideas among his pupils, and he was dismissed from the City by the pious Emperor Manuel and the Church. Their only mistake was that they refrained from denouncing him to the public, and failed to send him into dishonourable exile in barbarian territory, or in some other way to prevent the harm that was to come from him (Woodhouse, 1986).

According to C. M. Woodhouse's findings in the texts surrounding Gemistus, Emperor Manuel was a Neo-Platonist sympathizer and our hypothesis is that he protected Gemistos by placing him at the court of his relative at Mistra where he became the Chief Magistrate and was able to carry the tradition of teaching philosophy in the direct method typical of Platonic Academies.

Platonic Academy in Florence

It seems that a Platonic Academy needs to be seeded by a trained and practicing Platonist. Since closing the Academy in Athens in the fifth century BC with Proculus as a last teacher and the destruction of Hypatia and the Alexandrian Library at about the same time, the likelihood of finding one fully trained for the Florence of the early 14th century is very small. The History of culture is full of examples of tenacity and ingenuity of continuation of traditions under most difficult circumstances.

Florence

Cosimo the Elder in 1434 inherited the Medici Bank, became the head of the Medici Family and de facto head of state of the Florentine republic without having to hold a political office.

Cosimo embodied the concept of true leadership that knows what people can do and creates conditions for them to excel. This is true for any profession, there are examples among educators, theater or film directors and conductors. The Roman Emperor Hadrian was legislator, strategist and architect initiating some fine and memorable buildings and managing the Empire by a remarkable choice of people.

Cosimo knew the balance of statement – understatement and the value of cultivated discernment and he had a sense of the role of Florence and the needs of his time. He was not a rich man of parochial outlook buying respect through outer forms. He was well-educated, constantly learning and surrounding himself with the best minds and talent of his day. The match of deep outlook, interest in transcendence, but also in the ideal form of government and matters of legislation, made Cosimo and Gemistos perfect co-respondents. Creating conditions where Platonic ideas could be taught in the open must have appealed to both of them. The new Platonic Academy was born.

Constantinople

The capital of what survived of the Eastern Roman Empire was almost an opposite story to Florence. Constantinople was overgrown with consolidating, conserving politics at every level. Imperial family infighting, dogmatic and politicized church and a weak army were contributing to the sense of ailing empire, a sense of a different and new future was completely absent. It was a matter of decades and then years of impending conquest by any of the multiple contenders. The minds like Gemistos were not welcomed, only the procedural pedantry ruled the day. But the deepest sickness of any culture is not the benign neglect of the past due simply to the passage of time, but a vigilant self-loathing of the previous phase and its history. The Byzantine Empire by persecuting its own pagan culture forced it to go underground and flourish at neighboring cultures that absorb them.

This is why the timing of the raising of Florentine renaissance and the living connection to generative ideas are a seeming miracle of the meeting of these two strands of Mediterranean culture, the strand of a living germ hidden within an imploded seed and the numinous flow of rejuvenating, affirming instinct.

In 1438 the Byzantine Emperor John VIII Palaiologos headed a delegation with Patriarch Joseph of Constantinople to the west hoping to create powerful allegiance with the Pope in defending his largely shrunken and tittering Empire against the rising Ottoman powers. At Ferrara a joint council was arranged with the Pope to discuss possible union of the Orthodox and Catholic Churches. Because of the rumors of plague, Cosimo Medici suggested that the proceedings be redirected to Florence at his expense. Although not a churchman but a secular philosopher, Gemistos was invited to accompany John VIII Palaiologos on the grounds of being highly recognized by some of his contemporaries, a Greek version of the concept of *stupor mundi* the marvel of the world, a subject of admiration and wonder. It was believed that Gemistos knew the entire legal system by heart (as a proponent of the cultivated oral tradition, he must have had a similar connection to the philo-

sophical knowledge), he had a reputation of generosity as a teacher and of living to the highest standards of ethics.

Already a decade before the Council of Florence, Gemistos was consulted by the Byzantine Emperor on the issue of unification of the Greek and Latin churches. Eventually at the Council of Florence the document of the union was created, agreed upon and signed. It was so watered down that the agreement was a matter of trivial technicality. Immediately after the council both parties ignored it and the Byzantine clergy saw it as usurping their imagined supremacy as inheritors of the first Christian Roman Emperor Constantine. At times the schism of the two churches seems to be more about the politicized Apostolic or Imperial succession than about some theological differences. Hidden within the history of events, the Byzantine clergy's valiant guarding of the Imperial succession stemming from Emperor Constantine's conversion, had not been studied as a recurrent pattern and one of the causes of demise of Byzantium.

At the Council of Florence the real union happened behind the scenes not only of two views of Christianity but also many strands of Mediterranean learning. Gemistos was invited by Florentine humanists to lecture on Greek philosophy. Because Gemistos was not an ecclesiastic functionary but a secular scholar, he was needed at very few sessions of the council. Cosimo de' Medici attended Gemistos' lectures, as he also was not an ecclesiastic but a lay citizen of Florence. The documentary material about what happened in those meetings is very minimal and most commentators conclude that Cosimo was so inspired by this lectures and Gemistos' teachings that it prompted him to found the *Accademia Platonica* in Florence. As we have mentioned before, Gemistos did not write his concept or processes, but mostly summaries. These notes are his mini-reference library allowing only indirect glimpse of his teaching. The relationship to books or reference material by the scholars was completely different before the printed book, memory and oral traditions played a great part in holding the knowledge.

Gemistos' lectures and Cosimo's attendance at them must have been a climax of a process of direct or indirect communication most probably started a decade or more before. Medici's have been collecting Greek and Roman statues with pagan motives, manuscripts connecting to traditions of Kabbalah, ancient Egyptian alchemy, Hermetic tradition and Muslim medicine and science for their library. It opened as a first public library in Europe in 1440. Cosimo's interest in philosophy and a philosophic basis of government must have led him to Gemistos. They could have communicated with each other through Gemistos' students and Italian merchants traveling through Greece. Probably the reason Gemistos was enlisted in the Byzantine Emperor's delegation is because of his contacts and the respect he held in Italy. After the council and sojourn in Italy, far reaching was the influence of Georgius Gemistus *Pletho* on the Florentine Humanist Marsilio Ficino, the first director of the Platonic Academy in Florence. Today Gemistos is considered one of the most important influences on the Italian Renaissance. The Medici's did not

unearth broken statues and found rare manuscripts they also connected to living breathing tradition embodied by Georgius Gemistus *Pletho*.

If we read the material carefully and caringly presented by C. M. Woodhouse and add our comparative thought on teaching transmissions, it could be summarized that Gemistus intentions were never to be original or remembered but simply to carry the inspiration and creativity inherent in the Platonic Training applied to his time. Just like the effectiveness of a fertilizing germ, it is not the uniqueness of its form that matters but the vigor of carrying the cellular signature forward.

11. Conclusion

To add to the understanding and discourse about the History of a Sea, The White Sea to the Ottomans, *Mare Nostrum* to the Romans, the Mediterranean, we looked at the intangible cargo of cultural currents and the elusive itineraries and osmosis of ideas. Springing from five examples of intellectuals, we explored teachers, religious leaders, artist and experts who were appointed or inadvertent advisers at Byzantine, Ottoman and Renaissance courts.

Starting with a short reflection on Scilla and Haribda and the Mediterranean navigability of Ulysses, we explored the gates of Bosporus and the Black Sea of the Argonauts expedition, Western Mediterranean and Atlantic trade routes of the Phoenicians, and the dependence of Venetian prosperity on Indian Ocean winds.

The first example is the life journey of the musician Ziryab (789-857) arriving to Umayyad Spain from Abbasid Asia Minor as cultural, political exile. Welcomed by the ruler Al-Hakam II with whom he created a living partnership, inspiring a cultural nexus that made Al-Andaluse and Cordoba the intellectual and artistic center of their time, 8th and 9th century Iberia and that continue to this day. It is rare in history that an adviser was listened to and given a chance to implement so many well considered ideas in multiple fields. It is also rare for a patron to develop a deep working, life long relationship with an adviser. The long journey from Baghdad to Cordoba bore fruits.

The reason we follow the description of Ziryab's great and inspiring journey westward from Baghdad to Cordoba with a brief account of Ibn Arabi's influential passage eastward from Seville to Damascus, is to give a sense of the comparable wave of cultural influences from west to east in the proceeding centuries after Ziryab. This is a way to set up some observable parameters in studying influences and counter-influences and helps us understand how intangible heritage can play a role in giving a greater depth and understanding history.

Among examples is the sojourn of St. Frances's of Assisi in Asia Minor. By viewing his life from the point of view of Mediterranean cultural currents and possible non Christian interfaces and influences validates and makes credible his contribution.

Ramon Llull's quintessentially Western Mediterranean thinking anticipated the scientific methodology and heralded *Reconquesta* ideology of converting all Mus-

lim and Jews. He received a number of revelations that led to a creation of his system, he believed in the objective validity of his work regardless of any personal involvement. This is very different from George Gemistus Plathon, the central example of the paper, whose quintessentially Eastern response to receiving and transmitting knowledge influenced Italian Renaissance.

The central example of intangible cargo is a gift of ancient Greek Philosophy to the Italian Renaissance by George Gemistus Plathon, probably the last known fully trained Platonist. He was a Member of the delegation headed by the Byzantine Emperor John VIII Palaiologos in 1438 and enlisted help from the Pope. The paper deliberates about the Gemistus presence facilitating the formation of the Platonic academy in Florence.

The fresco by Benozzo Gozzoli commemorates the Byzantine emperor's visit and emergence of Neo-Platonism thought in Florence. The fresco was started in 1459, five years after the death of Gemistus and four years after the fall of Constantinople. It represents outwardly the cavalcade of the Three Wise Kings, the Magi that winds round the chapel of the Medici Palace. The fresco can be looked at as if a visual summary as well as an illustration for our discourse.

In the painting we see a portrait of the Mediterranean people and representatives of several cultural strands including an African prince among the pages. The Patriarch of Constantinople is represented as the Old King, the boy Lorenzo de Medici stands for the Young King and Emperor Palaiologos for the Adult King. But the most fascinating layer of the painting is the group portrait of the supporters of the kings. Studying the faces and the juxtaposition to each other, it is an archeology of influences and counter influences. Among the faces that scholars have identified are a number of people, members of Medici Family, scholars and artists like Marsilio Ficino, Pico della Mirandola, the painter Fra Angelico and Gozzoli's self-portrait next to the representation of Gemistus. This group was the one that held the birthing of the Italian Renaissance rooted in many living and revived currents of the Mediterranean Cultures. A possible archeology of faces in Gozzoli's painting can lead us to a rich intercultural mix. Just as when we look through visual inventory of ancient and more recent Mediterranean sunken ships, we find not only practical objects imbued with images, symbols and form that crisscrossed the Middle Sea but also the objects that are purely ceremonial, votive and devotional fulfilling cultural needs of the Mediterranean people. Following a training of skills for production, subsequent distribution of these pieces and the intangible conception and lore that surround them, is a story, history of the sea itself.

References

- Atiyeh N. G. (1998). Ibn Masarra, Muhammad ibn ‘Abd Allah (883–931). *Routledge Encyclopedia of Philosophy*, 1.
- Bardakoglu, A. (2008). Culture of Co-existence in Islam: The Turkish Case. *Insight Turkey*, 10(3). 111-126.
- Batzarov, Z. (2000). *Orbis Latinus*. Retrieved from <http://www.orbilat.com/index.html>.
- Cunliffe, B. (2001). *Facing the Ocean – The Atlantic and its People*. Oxford: Oxford University Press.
- Helminski, A. C. (1994). Women & Sufism. *Gnosis*, 30.
- Ibn Arabi. (1988). In R. W. J. Austin (Ed.), *Sufis of Andalusia*. Sherborne: Beshara.
- Menocal, M.R. *Ornament of the world*. New York: Little- Brown and Company.
- Paich, S. D. (2008). *Transmigration of Music: The Significance of Itinerant Musicians in Mediterranean Cultures*. Athens: International Conference on Mediterranean Studies.
- Ribera, J. (1929). *Music in Ancient Arabia and Spain*. London: Humphrey Milford Oxford University Press.
- Robinson, A. R. & Leslie, W. G. (2001). *Mediterranean Sea Circulation*. Harvard, MA: Academic Press.
- Teleki, S. K. (1967). *Sumerian origin of the names of the river "Ister-Danube"; a study in prehistory and philology*. Michigan: University of Michigan Press.
- Woodhouse, C. M. (1986). *Georgius Gemistus Pletho: The Last of the Hellenes*. Oxford: Oxford University Press.
- Yates, A. F. (1966). *The Art of Memory*. London: Routledge.

Dutch Navigation in Sicily in the First Half of the Seventeenth Century

FEDERICO RIGAMONTI

1. Introduction

The increasingly important role played in Mediterranean waters by Northern seamen since the end of the Sixteenth Century has long been a favourite topic among maritime historians for the early modern period (Braudel, 1967)¹. Some scholars have considered the phenomenon an invasion (and takeover) of the Mediterranean, while others have tried to soften and correct this view in recent years (Greene, 2002). From both perspectives it is however widely acknowledged that the Dutch and the English became heavily involved in carrier trades in the Mediterranean, which was at the same time a consequence and a cause of the decline of nations of long-lasting maritime traditions, such as the Venetians. Most studies focus on Northern Italy and the Levant, whereas Sicily and Naples have so far received less attention. This is no doubt the consequence of the lack of sources such as the Levant Company Archives or the Livorno *Portate* (Braudel & Romano, 1951)², or of published sources like Brulez 1965 and Brulez and Devos 1986. The assumption that the Northerners found in Naples and in Sicily, as parts of the Spanish composite monarchy, a hostile environment in comparison to Livorno, Venice and Genoa must also be taken into account (Koenigsberger, 1947; Pagano, 1990)³. Furthermore, most scholars of Sicilian maritime history for the early modern period have chosen to focus on sources which are not fit for providing robust information on matters such as masters' and ship owners' nationality or deadweight tonnage (Benigno, 1982; Cancila, 1972; 2001; Gotteri, 1969; Trasselli, 1962; 1967)⁴.

This paper aims at showing the status reached by Dutch navigation in Sicily

¹ As regards to Genoa, see Grendi, 1968; 1971.

² For further studies on this source, see Engels, 1997 and Ghezzi, 2007.

³ Studies on Naples have focused on English merchants and seamen (Koenigsberger, 1947; Pagano, 1990).

⁴ For a broad study on Sicilian port facilities, see Simoncini, 1997.

while also explaining the process by which it was attained, from the last years before 1609 until 1648⁵. The research is mainly based on the wealthy notarial archives of two of Sicily's most important ports, Palermo and Trapani (Messina notarial archives for that period being mostly missing), which provide much information on Dutch presence in form of charter-parties, maritime insurances, and a wide variety of other deeds offering some insight on the relation between Dutch seamen and Sicilian (or Sicily-based) merchants, brokers and charterers⁶. These data are put together with those obtained from institutional sources, such as the *Maestro Portulano* (which was competent on wheat exportations) and the *Real Segreteria*, which in turn highlight how State officials perceived, represented and in some cases hid the Dutch. This study is divided into three sections: the first deals with the Twelve Years' Truce period (and the last year preceding it), when Dutch ships made their first appearances in Sicilian ports. Although choosing a *terminus a quo* for the phenomenon is hard, 1608 seems to be a viable option, since it is the first year in which the Dutch can be supposed to have purposely entered Sicilian ports. After 1609, their numbers increased and they began to take control of salt and wheat transports. The second section starts with the end of the Truce (1621), which was certainly a setback for Dutch navigation in Sicily, albeit a temporary one. Over the following fourteen years, the Dutch managed not only to survive but also to grow, especially after an attempt to stop them failed in 1628-1629. Finally, the third section is about the years from 1635 onwards, when war between France and Spain meant for the latter that it had not only to tolerate the Dutch, but even to hire them for a wide and unprecedented range of maritime services.

2. *Rising to prominence (1608-21)*

By the beginning of the Seventeenth century, the Dutch had gained a strong reputation as sailors, and had already made their first appearance in Italian ports due to dramatic harvest failures in 1590-1594. In 1604-1608, a second dearth called for new imports of Baltic grains and, as a consequence, for Dutch ships to carry them (Pagano, 1996; van Gelder, 2004)⁷. However, until the signing of the Twelve Years' Truce their presence in Sicilian ports seem to have been marginal⁸. Not only were they rebels to His Catholic Majesty, but they also faced harsh competition

⁵ Quite curiously, Flemish merchants active in Sicily during the Seventeenth Century have been so far studied by art historians only: see Abbate, 1999 and Gozzano, 2011.

⁶ Notaries have been identified according to the methodology suggested by Vigiano, 2004. For some researches in maritime history for the early modern period based on notarial sources, see Cingari, 1979 and Tenenti, 1985. See also Lentini, 2004.

⁷ For an outline of wheat production and trade in Sicily in the early modern period, see Aymard, 1976 and Cancila, 1983.

⁸ Before 1608, the only "Dutch" (and he could have been a German as well) I have found in notarial records was a Paul Pitresen, whose ship had been wrecked near Vendicari in 1595 (ASP, ND I, v. 8541, ff. 965r-6v, 20 march 1596).

from other maritime actors such as the French and the Ragusans. Moreover, some factors made Sicilian trade less dependent on big carriers, and therefore on the Dutch, for some years. The first and foremost of these was the dearth in 1604-1608, which caused wheat exports to cease for a while. However, as it also prevented the English from entering such a rich sector of maritime transports, the Dutch might have benefited from it.

Two more factors, however, were far more important and would require some years to be successfully overcome. By 1609, Sicily's main ports lacked Flemish, or even German, merchants⁹ or craftsmen who could be of help to the Dutch and this, even if did not eventually prove too big an obstacle, would hamper Dutch presence in the Truce's first years. English masters could also not rely on their fellow-countrymen before 1609¹⁰, but this did not apply to the Ragusans, and even more crucially to the French, whose consular network covered Messina, Palermo and Trapani. Moreover, language was not a problem for Mediterranean sailors. Some French masters even resided in Sicily, and acquired Sicilian citizenship by marriage. On other hand, Genoese, Florentine and Catalan merchants did not show a definite preference for masters of any nationality, and the Dutch did enjoy (together with the Germans) an excellent reputation as sailors¹¹. However, this did not entail that the Dutch should obtain more freights, or more easily, than their Mediterranean competitors. On the contrary, available evidence suggests that they entered the Sicilian market for charter-parties quite late, and even then very slowly: the first charter-party drawn in Sicily which has been found in Sicilian archives dates to 17 September 1611¹². Surviving evidence also shows that for some years Dutch ships were chartered for Sicilian cargoes in ports they had been free to enter long before 1609: Livorno, Genoa and Venice¹³.

Last but not least, the Dutch would find their ships were not very fit for voyages to and from Sicily. Salt apart, big ships were not well suited for Sicilian products, which were mostly exported in small lots to Italy, Mallorca and Barcelona. The same applied to imports from all places but Venice and, to some extent, Spain and

⁹ For thorough (albeit quite outdated) studies on foreign merchants in Sicily in the first half of the Seventeenth Century, see Gotteri, 1969; Trasselli, 1978; Cancila 1978; 2001.

¹⁰ There is no evidence of English merchants active in Sicily before 1610, when one can find the first traces left by a Robert Chin (King?) in Trapani and a Henry Campiore (Champion?) in Messina (ASTp, Notai, v. 10275, f. 601r, 24 July 1610; v. 10276, ff. 53r-v, 28 September 1610). Besides, Robert Chin never chartered English ships, usually giving his preference to French and German masters.

¹¹ Unlike, it would appear, the English. Even an Englishman, Robert Chin, once gave a French master a power of attorney to charter for his account in Livorno one or two vessels under the command of Dutch or German masters («fiamenghi alemanni olandesi o tudeschi et non di altra nactione») for a voyage to the Levant or the Black Sea (ASTp, Notai, v. 10275, ff. 622r-3r, 5 August 1610).

¹² ASP, ND II, v. 757/b, ff. 21r-2v, 17 September 1611.

¹³ See also Pagano, 1996; Engels, 1997 and van Gelder, 2009a.

the Levant. Even if big ships did offer lower freight rates¹⁴, small ones widely won the race for transports of light commodities such as textiles. Nor were the Dutch able, for some time, to enter the spice trade: by 1622, nearly all of Sicily's imports in spices would still arrive at Messina from Alexandria¹⁵, usually on board of Ragusan, French and Genoese ships. The Dutch seemed thus eligible for bulky goods only, such as staves, ropes and hoop iron from Barcelona and Alicante where, however, they had to face Spanish embargoes until 1609. Of course, smuggling would have allowed them to come to Sicily and sell their cargoes. Even then, finding a return cargo would be hard. Highly valued commodities would require either waiting too long in the ports, or filling a small portion of the hold, while the exportation of cheaper goods such as wheat and barley was so tightly controlled by State authorities, that trying to fool them would have been very dangerous. As a consequence, the only good which Dutch ships could load in substantial quantities, either on their own account or on freight, was salt¹⁶. Unsurprisingly, Dutch ships could be found since at least 1608 just in Trapani¹⁷, where they could even rely on a consul for assistance: a Captain Emmanuel de Andrada, who was able to speak Dutch and German¹⁸, and whom Dutch masters would soon learn to trust and esteem. Trapani was Sicily's third most important market place, and the one exporting most of Sicily's salt while also offering a wide range of goods which could be bought to complete a cargo, even on master's account: tuna fish, cheese, wine, vinegar, coral works and hoop iron (Benigno, 1982; Cancila 1972)¹⁹. Given these circumstances, it is no wonder that after April 1609 Dutch ships would prosper in Trapani. Very soon, their masters also showed their stubbornness and mistrust of Italians²⁰, often refusing to comply to their requests unless they were assisted by *their* consul, de Andrada²¹. In 1612, their presence in Trapani was even noticed by State authorities and the duke of Osuna, His Majesty's Viceroy, decided to sanction the state of things by appointing de Andrada as the official «consul general de las naciones flamenga y alemaña» in the

¹⁴ In 1619, the freight paid for a bale of Flemish textiles from Genoa to Palermo to frigates and feluccas was more than twice that asked by ships (ASP, ND I, v. 17614, ff. 1136v-40r, 23 March 1620).

¹⁵ AST, *Sicilia*, n. 15, f. 5r.

¹⁶ Another prominent Sicilian export, which the Dutch could have bought in great quantities in Messina, was raw silk. However, it was also very expensive, costing about 3 Spanish dollars per Sicilian pound (0,317 kg) in the early decades of the Century.

¹⁷ For an interesting study on salt trade between Trapani and the Kingdom of Naples, see De Stefano, 1982.

¹⁸ ASTp, Notai, v. 10274bis, ff. 41v-2r, 9 September 1608.

¹⁹ Unfortunately, there is an almost complete lack of researches of this kind on Palermo. One can only refer to Vigiano 2004, which however focuses more on the mid-Sixteenth Century, and to Ago 1998 whose description of Rome in the early Seventeenth Century is quite similar to what can be detected for Palermo from notarial sources.

²⁰ On this topic, see also van Gelder 2009a.

²¹ ASTp, Notai, v. 10276, ff. 35r-v, 13 September 1610, and ff. 68r-9r, 12 October 1610.

whole Kingdom, though he ordered him to reside in Trapani²².

However, this did not mean that Dutch shipping was flourishing in Sicily as a whole. There is no evidence at all of Dutch involvement in transports of other Sicilian goods except wheat – and even then, their role in Sicily’s most important export was small. There were few Dutch ships in Palermo, and even fewer charter-parties: in most cases, charter-parties were drawn in Genoa or Livorno, and the master called at Palermo just to receive instructions on where to load his cargo. The first registered transport on board a Dutch ship took place in April 1610, and even after then, it took some years for the Dutch to become prominent actors in this sector, as the table below (Table 1) clearly shows²³:

Tab. 1. *Transports, quantities and destinations of the cargo mentioned in the paper.*

Indictional Year	Wheat transports	Quantities (in salms)	Of which: for foreign destinations
1609/10	6	9000	9000 (100%)
1610/11	5	7000	7000 (100%)
1611/12	5	6700	1800
1612/13	3	3924,5	3924,5
1613/14	5	6012	2504
1614/15	7	8800	7800
1616/17	5	11400	11400
1617/18	19	27900 + ?	21700
1618/19	27	43950	43950

Two middling harvest in 1611-1612 may explain the reduction of wheat transports, but there are good reasons to suspect that this was not the true cause of such a phenomenon: transports by French and Genoese ships did not show a similar decrease, and even Sicilian and Neapolitan ones were able to keep their shares in those (quite) bad years. Actually, the Dutch were newcomers on the Sicilian scene, even more than five and more years after the Truce. This could not be crucial in salt transports, in which a charter-party drawn in Genoa or Venice, or just having some cash to buy a cargo would be enough²⁴, since the salt trade was not subject to restrictions or control. This was not true for wheat. Export licenses (*tratte*) were one of the main sources of revenue for the Kingdom of Sicily and an ad hoc magistrate, the *Maestro Portulano*, was charged of controlling wheat exportations. Wheat could be exported from some ports (*caricatori*) only, a few of

²² ASP, RS, v. 1, ff. 75r-6r, 12 May 1612.

²³ Only masters clearly identified as Dutch, either by the source or from other information, have been included; however, even adding the dubious cases would not alter the picture.

²⁴ Salt was a very cheap commodity. A salm (Its 275.088 or kgs 550 ca) never stood higher than 8 taris first cost, and most often lower than 7 taris.

them being part of some aristocratic families' demesne. Moreover, exportation to His Majesty's enemies was strictly forbidden. An exporter had to buy as many *tratte* as were the salms of wheat – or barley – he wished to load, and then get permission to export. This could be had in two ways: by means of a second license (*littera* or *licentia extrahendi*) issued in his name, or by having the master promise to consign, within a given period²⁵, a receipt stating that the cargo had been unloaded in an authorized destination (*responsale*)²⁶. At least two persons had to stand guarantee for the master. Quite obviously, merchants usually preferred a *responsale*, as these mentioned the master and his guarantees only. However, as the latter were subject to heavy fines whenever the master failed to fulfil his promise, a *responsale* must have been expensive for a master, the more so for a newcomer. Some petty merchants, shopkeepers, craftsmen and notaries were used to stand guarantee many times a year and even made a business out of this. Some of them focused on their fellow-countrymen, while others did not show any preference. In July 1611, de Andrada stood guarantee for a Dutch master²⁷, but he then relinquished this role for six years²⁸. Since 1611, Dutch masters could rely on two more guarantees, Simon Le Maire and Cornelis de Guglielmo (Engels, 1997; Tihon, 1938)²⁹. Le Maire was appointed Flemish and German consul in Palermo by the Viceroy in 1613³⁰.

Matters, however, did change only from 1617 onwards. By then, both de Andrada and Le Maire had been confirmed as consuls, the former in 1616 by the new Viceroy, the count of Castro, who cancelled the condition that he reside in Trapani, and the latter by the Staten-Generaal in 1617. Both were very active as guarantees, but that was not all. After 1617, there were important arrivals in Palermo boosting Dutch involvement in wheat transports. Jérôme Ratton, who acted as Le Maire's consul deputy, came to Palermo in early 1618. He had strong ties with the Flemish community in Naples, and was very active as a merchant in clothes, textiles and salted fish. Hendrick Dych (Dijch), who arrived in March 1619³¹, could also rely on links with Mark Moens in Venice and (perhaps more

²⁵ From two months for destinations in the Kingdom of Naples, to eight for the Iberian Peninsula. *Responsali* seldom mentioned destinations, except for voyages to the Papal States.

²⁶ Unlike *licentiae extrahendi*, *responsali* were also needed for domestic transports. *Licentiae* did not mention the master's name; they were normally issued for one or more ships («una vel pluribus navibus seu barcis»). This is of course a major issue about the reliability of the *responsali* as the source signaling all wheat transports on board Dutch ships.

²⁷ ASP, MP, v. 565 f. 136r, 8 July 1611.

²⁸ ASP, MP, v. 570, f. 153v, 15 June 1617.

²⁹ Simon Le Maire is also known as the first Staten-Generaal appointed consul in Palermo. Cornelis de Guglielmo was perhaps Cornelis Willemsz van Vinckeraet, who would later be one of the main correspondents of the Livorno-based Dutch firm van den Broecke & co. (Engels 1997).

³⁰ ASP, RS, v. 1, ff. 133r-v, 18 July 1613.

³¹ ASP, ND I, v. 17613, ff. 1330v-5v, 12 June 1619. His arrival nearly coincided with Le Maire's departure for Livorno; Dijch immediately took his role as guarantee for Dutch masters, and three years later would have been appointed Flemish and German consul. De Andrada, who became the Viceroy's Treasurer by 1618, was not mentioned after November 1621 (ASP, MP, v. 574 f. 67r, 29

crucially) with the Catalans. That year, Jan de Potter established himself as a merchant in staves and fish in Trapani. Much less is known about Messina, but some years later (1624) that city would host a Flemish community, not just a few merchants. By then, the same applied to Palermo as well. These arrivals meant that the Dutch were no longer newcomers. This, together with the slow but steady decline of the Ragusans, would help them to become the main carriers of Sicilian wheat to foreign destinations. The *responsali* series gives no data for the two last years of the Truce, but it would appear that the growth begun in 1617 continued. In just four months (December 1619-April 1620) underwritings for insurances on wheat on board of Dutch ships, such as can be detected from the deeds of four notaries active in Palermo, amounted to over 60.000 onze (slightly less than 180.000 Spanish dollars). Nor was wheat the only commodity in which the Dutch were successful. Since 1617, they were also involved in transports of more expensive goods such as tuna fish, sugar and currants. As it also had happened elsewhere, wheat (and to a lesser extent salt) had been the *moedernegotie* for the Dutch who, after 1617, were becoming more and more attracted by Sicily, as the same names (and ships) occurred more than once in a few months.

This dramatic growth also reflected an increased ease of the Dutch, who were now much more ready to claim their rights against Palermo-based merchants, something which had previously been true for Trapani only³². Charter-parties also became much more advantageous for them. Freight rates were equal to those paid to other masters, but the Dutch were now able to claim primages and demurrages. At the same time, both the portion of Dutch ships coming to Palermo directly from the North Sea and that of masters unable to speak Italian grew substantially higher, as well as the number of charter-parties drawn in Palermo rather than outside Sicily. It appears that, as Palermo became quite less dependent on foreign ports such as Genoa and Livorno, the role of the latter as “Dutch-providers” greatly decreased. What really mattered, however, was that by 1620 the Dutch were about to become the masters of the maritime routes connecting Sicily to most of the Mediterranean shores. Ragusans and Catalans were slowly withdrawing. The Genoese, though important, were not serious competitors. The English had never been a real threat: there is no evidence whatever of their involvement (even marginal) in corn transports before 1620. Only before 1609 were (a few) English ships able to get salt charter-parties. It looks like the English could somehow reach Sicily, but finding a return cargo was hard, not to say irksome. This must have been due to some extent to the Dutch superior techniques and skills, which even the

November 1621), nor was Cornelis de Guglielmo, who died in Palermo sometime before October 1626 (ASP, ND I, v. 17621, ff. 751v-5r, 9 January 1627).

³² This did not mean, however, that Dutch masters preferred a wheat cargo to a salt one; on the contrary, salt remained their first choice. In many cases, wheat charter-parties were drawn in Palermo after the master had been unable to find a salt voyage in Trapani (where the ship was at berth). In 1620, a Dutch master gave up a wheat transport he had already struck with a Genoese firm in order to load salt in Trapani (ASP, ND II, v. 1083, ff. 1148v-9r, 22 May 1620).

English were willing to acknowledge, and to the lack of English merchants of consequence in Sicily, but also and perhaps more crucially to their being perceived, unlike the Dutch, as the “public enemy number two” just after the Turks: ruthless corsairs just like the Turks³³, unholy (and wicked) slaughterers of catholic martyrs just like the Turks (Galioto, 1597).

Thus, the only and last competitors of the Dutch were, by the end of the Truce, the French who, as regards wheat and voyages to and from Spain, enjoyed an enviable position: not only were they the main carriers of Catalan hoop iron, but also the only ones whom the Spanish crown employed for very well paid transports of troops and ammunition from Spain to Sicily, where they could find a return cargo to Spain (wheat) or another one to Venice (salt). In Spain, they could also load barilla for Sicily or Venice, or wool for Venice only. Besides commodities and troops, they also did other services to the Spanish authorities in Sicily: between 1611 and 1616, the duke of Osuna had employed six Marseillais vessels, headed by Vinciguerra, for piracy against the infidels (Barbe, 1992)³⁴. However, by 1620 the Dutch were firmly established among the most prominent carriers of goods to and from Sicily. The end of the Truce would pose a serious threat to the Dutch. Some factors, however, would eventually help them to survive the storm unharmed, and prosper in the following years.

3. Setbacks, perseverance and growth (1621-1635)

The end of the Truce was no doubt a heavy blow for the Dutch in Sicily. Some were taken by surprise and fell into the hands of State authorities who promptly seized their ships. Still early in 1622, some masters tried to fool the new embargo declaring they were unaware the Truce had expired³⁵. Most of them, however, preferred avoiding Sicily. In the indictional year 1621-1622, consequently, the number of Ragusan ships involved in wheat transports suddenly grew³⁶. It also appears that Dutch ships became slightly less numerous even in Trapani.

It was a setback, not a disaster. Although many ships were seized, masters and crews were never jailed and could freely demand their ships back. Dijch, though not always unselfishly, cooperated loyally and most ships were usually given back in a few months³⁷. His appointment as general consul in May 1622 strengthened his

³³ «Qui si fa grandissima preda da Turchi, et Inglesi, quali con tartanei, navi, e bertoni rovinano il mondo» (ASP, ARC, v. 566, unnumbered sheets, Tunis 11 December 1608).

³⁴ This caused some friction the Granduchy of Tuscany: see Martelli & Galasso, 2007.

³⁵ ASP, ND I, v. 17616, ff. 1222r-4v, 15 April 1622.

³⁶ ASP, MP, v. 574.

³⁷ In May-June 1624, seven “Flemish” masters whose ships were then at berth in Palermo declared that thanks to Dych «quest’anno mediante sua diligenza sono salvati e liberati dalle mani del fisco quatro vascelli» (ASP, ND I, v. 17619, ff. 1144v-6r, 30 July 1625: Italian translation of a petition dated 22 May to 29 June 1624; this document also shows that by 1625 the Flemish community in Palermo numbered six at least). However, in 1621 Dijch had taken advantage of the

position. The Ragusan surge proved short-lived, and after 1624 their decline sped up. The English did not arrive in any significant number³⁸. Since 1624, many Germans and Scandinavians would appear in Sicilian ports: some of them, however, were actually Dutch under disguise. The French, who could have profited of the end of the Truce, began on the contrary to disappear from the scene in favour of the Dutch. The French would remain among the most prominent carriers to and from Sicily until 1635, but after 1620 all French ships would actually be small ones – and even frigates and feluccas – while the big ones almost suddenly disappeared. The end of troop transports from Spain to Sicily was perhaps a reason for this. This withdrawal meant that the Dutch and the French were no longer competitors, at least not to the same extent as the Dutch and the Ragusans were. Notaries willingly helped the Dutch: all the *flamenghi de Orno* or *de terra nominata Ancusa* (Enkhuizen) were now *de Amburgh*, *de Danimerca* or *de Dansich in regno Polonie*. Some State officials went even further: a master labelled as *de Hamborgo* in May 1625 became, eight months later, a Ragusan³⁹. Moreover, new arrivals had enriched the Flemish communities in Palermo and Messina, while Naples was home to many big merchants and ship-owners such as Gaspar de Roomer. Ratton had left Palermo for Naples in 1620, but artists and craftsmen such as Jan Baskens, Jeroen Gerardi⁴⁰ and Gerrard Theodoro had arrived the same year. In 1622, it was the turn of Hector van Achthoven, Andreas Rademacher and a Hector de Cornelio in Palermo, while Rudolf Oloffs and others were active in Messina⁴¹. Even more important, however, was the establishment of Jan Reijnst & Abraham Heijermans, a Venice-based firm which after 1625 became the salt supplier for the Duchy of Milan and Savoy (Engels, 1997). In order to achieve this, they needed to control salt production in Ibiza, Augusta and Trapani. For the latter they had recourse to Dijch, who by 1627 would manage four of the main salt pans of Trapani⁴², where from 1626 onwards the number of Dutch ships rose again⁴³.

embargo to buy a sequestered ship of 800 salms (about 80 lasts) from her master for less than 250 onze, an incredibly low price (ASP, ND I, v. 17616, ff. 551r-3r, 15 December 1621).

³⁸ The first, and for some years to come only, wheat transport attested in the *responsali* series dates to 1624 (ASP, RC, v. 639, f. 6r, 29 June 1624: the *responsale* has been included in a volume of the *Real Cancelleria* fund, apparently without reason). In 1623 Walter Colle (Hill?), an English merchant active in Messina since 1618, petitioned the Viceroy, His Most Serene Highness Filiberto of Savoy, asking that the clauses of the 1604 London Peace Treaty regarding English commerce be respected and enforced (ASP, RS, v. 4, ff. 149v-50v, 25 October 1623).

³⁹ ASP, MP, v. 579, f. 228r, 19 May 1625, and v. 580, f. 204r, 13 January 1626.

⁴⁰ On Baskens and Gerardi, see Abbate, 1999.

⁴¹ Van Achthoven was mentioned for the first time in ASP, MP, v. 574, f. 172v, 9 April 1622; see also Gozzano, 2011. For Rademacher, ASP, ND I, v. 17616, ff. 1224v-5v, 15 April 1622. In 1625, Rademacher went almost bankrupt and had to leave Palermo in haste: ASP, ND I, v. 17619, ff. 752r-4v, 26 March 1625.

⁴² ASP, ND I, v. 17621, ff. 1055r-6v, 10 March 1627. Dijch was the manager of the prince of Paceco's salt pans since 1623.

⁴³ ASTp, Notai, v. 10349, passim. Reijnst and Heijermans had been chartering ships for voyages from Venice to Sicily and back since 1625 (ASP, ND I, v. 8098, ff. 34r-v, 11 September 1625). For further information on this firm, see Ruspio, 2007 and van Gelder, 2009a.

Another factor was perhaps even more important for Dutch masters' perseverance: a dramatic shift in the flow of wheat exports. Until 1620, Spanish ports had received a fair share of the Sicilian harvests by means of direct exportations but, from that year on, things changed completely⁴⁴. As more and more charter-parties were agreed on in Sicily providing for Livorno and Genoa to be the only destinations, transports to Mallorca and Barcelona dramatically declined, and those to other destinations as Valencia or Cartagena completely disappeared. So big was this change that by 1622 the city of Valencia petitioned King Philip IV, complaining that in the last year importing corn direct from Sicily had been impossible⁴⁵. It is hard to determine whether the shift was caused by the end of the Truce or not⁴⁶, but there can be no doubt that it was highly beneficial to the Dutch, who did not have to be afraid of embargoes in Livorno and even in Spain-friendly Genoa⁴⁷.

This does not mean, however, that the Dutch enjoyed the same situation as in the last years of the Truce, nor were the years after 1621 ideal at any rate. Primages and demurrages had to be dropped, ships' seizures often forced masters to undertake long and expensive journeys to Palermo, and transports of other commodities than salt and wheat greatly decreased, as far as can be judged. A plague pandemic struck Palermo and most of the *caricatori* in 1624-1626, and all proveniences from Sicily were liable to long quarantines or could be denied pratique⁴⁸. After the plague, harvests in 1626-1627 were quite bad and caused exports almost to cease. And this was not the worst. In late summer 1628, after a good harvest promising many wheat charters, five ships were suddenly seized in Trapani: their cargoes were sequestered, and the crews were jailed. In December, Dijch was discharged as Flemish and German consul, and his place was given to a Spanish officer, Juan Ratteo.

It is unclear whether this chain of events was due to the Spanish officials' zeal,

⁴⁴ In the indictional year 1619-1620, charter-parties drawn by notaries public Sebastiano Brocco, Vincenzo Passigi and Francesco Sergio provided for 14.600 salms of wheat to be consigned in various Spanish ports, mainly Barcelona and Valencia. Over the following year, no charter-parties for wheat transports to Spain were drawn (ASP, ND I, vv. 17614-5; ND I, vv. 763-4, 1083-4).

⁴⁵ ASP, RC, v. 631, ff. 211v-3r, 6 September 1622. In 1614, Valencia had obtained from Philip III the right to import up to 8.000 salms of wheat a year from Sicily, free of *tratta*, for ten years.

⁴⁶ It is also plausible, corn being a bulky commodity just like salt, that increased arrivals of corn to Genoa "forced" the relocation of Ibizan salt to Venice. Abraham Heijermans resided in Genoa for some years before he moved to Venice where he struck his partnership with Reijnst (ASP, ND I, v. 17592, unnumbered sheets, 21 July 1638). For further information on salt trade between Genoa and Spain, see Kellenbenz, 1972 and Engels, 1997.

⁴⁷ Even if most charter-parties permitted to choose the destination between Livorno and Genoa, evidence suggests that most of the times the cargo was consigned in Genoa only. In those years, there was a fierce competition between the two ports for Dutch ships and merchants: see Engels, 1997. On the extent to which embargoes were enforced in Spanish ports after 1621, see Israel, 1989; 1990. For a different view, see de Vries & van der Woude, 1997.

⁴⁸ As experienced by the ship *San Paolo*, Jacob Zelandier master, in Genoa in April 1626 (ASP, ND I, v. 17621, ff. 83v-5r, 17 September 1626).

or to a combination of circumstances. Even if the first move was deliberately made by Captain Francisco de Hurtado, commander of the Royal artillery in Trapani, it appears that the Viceroy, the duke of Alburquerque, was taken by surprise. Even de Hurtado's zeal could have been self-interested⁴⁹. Given that, it is no wonder in October 1628 Giacomo Brignone, who was the official supplier of Sicilian galleys and as such a prominent importer of Norwegian wood and masts, decided to have a ship of 2.000 salms bought in Amsterdam, and he also appointed Jacob Janssen Vuron as her master (Engels, 1997)⁵⁰. In September 1629, he chartered one more Dutch ship to sail from "Flanders", take a cargo there and in Norway and proceed to Sicily⁵¹. Furthermore, state authorities soon discovered that while seizing some Dutch ships was one matter, being able to dispense from their services was another. The Dutch had almost become the only big carriers, and moreover, Spain was then at war with England, France and Denmark⁵². Wheat exporters had now to rely on medium and small ships under Genoese, Catalan or Sicilian masters. As a consequence, freight rates began to rise swiftly. In early fall 1628, a salm of wheat bound for Genoa or Livorno paid 9 Castilian reales, but by April 1629 the rate was an unprecedented 15 reales. Between April and June, some Ragusan ships were chartered in haste in Genoa and this helped to calm waters for some months, but in October 1629 freights were again on the rise: by December, a salm of wheat paid 16 reales for Savona, and even 15½ for Civitavecchia. The peak was reached in February 1630, when 19 reales were agreed for a voyage from Girgenti to Genoa.

As remarked by J. de Vries and A. van der Woude, Spanish embargoes were unlikely to last long if strictly enforced, and vice versa (De Vries & van der Woude, 1997). In Sicily the embargo did not last long after 1628. It is more very likely that, by late fall 1629, state authorities were under growing pressure from wheat exporters – who were also the King's main lenders – to allow Dutch ships in Sicilian ports, turning a blind eye on them once again. This was done and in December 1629-January 1630 the first charter-parties were agreed on – in all but one case, between exporters and the ship owners' attorney, a Francesco Barzellini from Bologna, active in Palermo since 1620 if not earlier. Since 1623-1624, he had had some business contacts with Dijch and by 1627-1628 he was perhaps the most trusted correspondent of the Flemish merchants of Naples and Venice⁵³. However,

⁴⁹ No doubt, de Hurtado took profit of his zeal, being appointed a senator of Trapani in 1629 (ASTp, Notai, v. 10352, unnumbered sheets, 12 September 1630). However, the real motive in his action could have been another. Dijch had moved to Trapani in May 1627 and, as the consul and his substitutes received a fee of 1 onza for every vessel entering Sicilian ports (ASP, ND I, v. 17619, ff. 1144v-6r, 30 July 1625), the sea of Trapani was a very lucrative one since 1626. In April 1629 a brother-in-law of de Hurtado's was appointed sub consul in Trapani (ASP, RS, v. 7, f. 104v, 12 April 1629).

⁵⁰ ASP, ND II, v. 1091, ff. 238v-40r, 14 October 1628. Brignone gave the commission to buy the ship to Willem Muilman, who had been a director of the *Directie van Levantse Handel* in 1627.

⁵¹ ASP, ND I, v. 17587, unnumbered sheets 3 December 1629.

⁵² However, war did not prevent French ships and boats calling at Sicilian ports in large numbers. The English, on the contrary, did not materialize before 1630.

⁵³ He even bought the ships sequestered in Trapani and had them sent to Naples (ASP, RS, v. 7, f. 104v, 1 September 1628).

it very soon became apparent that informal assurances were not enough for most Dutch masters, who were often unwilling to sail for Sicily: they still feared mistreatment⁵⁴, and knew moreover that they could obtain good freights in other parts of Western Mediterranean (Engels, 1997). In January, freight rates had ceased growing, but in February tensions rose again and this was reflected on the freighting market. It is unclear what may have passed in Palermo, between the biggest merchant-bankers and the Viceroy, and whether (and how long) the latter may have resisted suggestions to make the embargo completely void; however, the duke of Albuquerque gave in at last. On 7 March 1630, van Achthoven replaced Ratteo as general consul of the Flemish and the Germans. He was to keep this office except for a brief interlude until 1649, when a Staten-Generaal appointed consul replaced him. In August 1632, the newly appointed Viceroy, the duke of Alcalà, tried to reverse his predecessor's policy by appointing a new consul who was a Sicilian. This, however, very soon caused strong reactions from the Flemish communities in Venice and Naples, the latter nearly threatening to let their ships desert Sicilian ports, thus harming wheat exports and State revenues⁵⁵. The duke of Alcalà had no choice but to surrender: van Achthoven was reinstated *de facto* on 3 March 1633⁵⁶. Aiming at strengthening his position, van Achthoven asked for and obtained a patent confirming him as consul from Archduchess Isabella Clara Eugenia, General Governess of the Spanish Netherlands on 20 May. By the time this was acknowledged by Sicilian authorities, Archduchess Isabella had died⁵⁷, but his consulship was never challenged again.

The failure of the Spanish official to turn the tide or at least control Dutch ships entering Sicilian ports had long-lasting consequences. Available evidence suggests that, after 1630, no ship was seized by state authorities, as if the war between Spain and the "rebels" had ended. This was not all. Since the early phases of their return to Sicily, Dutch masters showed the same stubbornness which had characterized them up to 1621. Primages and demurrages were included again in wheat charter parties and, for the first time, it fell to the charterers to pay most expenses and in particular the *responsali*. As a consequence, the choice between these and the *licentiae extrahendi* became far less important for exporters – and, as the Dutch were still (officially) rebels to His Majesty whose nationality had to be hidden, they found much more convenient to have recourse to the *licentiae* most of the times.

⁵⁴ ASTp, Notai, v. 10719, unnumbered sheets, 2 July 1630.

⁵⁵ «Non remediando in ciò saranno forzati mandare in altre parti le loro navi in grave danno di S[ua] M[ajestà]» (ASP, ND I, v. 17625, ff. 545v-6v, 10 December 1632). The petition of the Venice community was much milder. It was drawn by notary public Giovanni Piccini and confirmed by Jaime Cardoso, consul for Spain and Portugal in Venice (v. 17625, ff. 543v-4v, date as above). On Piccini and Cardoso, see Ruspio 2007. For a broader study on petitions from the Flemish community in Venice, see van Gelder 2009b.

⁵⁶ This information has not been found in institutional sources (the volume which should have contained it has been lost) but in notarial ones, the first reference to this appointment is in ASP, ND I, v. 17625, ff. 1269r-72r, 5 April 1633.

⁵⁷ ASP, RS, v. 8, ff. 188v-90r, 16 January 1634.

The volumes collecting *responsali* became much thinner, while notarial records were now full of a new type of deed: the creation of attorneys «ad extrahendum seu extrahi faciendum» in some of the Kingdom's main *caricatori*. As had been (and, albeit to a lesser extent, still was) the case for guarantees on *responsali*, such novelty also called for professionals: in nearly all these deeds for exportations from Sciacca in years 1633-1645, the nominee was a Nicola Cappellano⁵⁸.

Van Achthoven spent part of his time in Messina since at least 1627, and settled there in 1629-1630, when he took over Rudolf Oloffs' business activities⁵⁹. Messina, however, was no market for wheat charters, nor was Trapani. As the Flemish residing in Palermo were craftsmen and artists, van Achthoven chose as his sub consul Francesco Barzellini, who in turn appointed many sub consuls for minor ports where Dutch presence was normal. Within end of April 1633, the "Flemish" consular network had sees (besides Messina and Palermo) in Trapani, Milazzo, Agrigento, Sciacca and Castellammare del Golfo, to which Mazara del Vallo and Terranova were added over the following years. Apart from Milazzo⁶⁰, all seats were main loading ports for corn or salt transports. Some omissions are indeed striking: Termini, Licata and Pozzallo were among the most active *caricatori*, and after 1637 also such ports as Catania and Acireale would see frequent callings of Dutch ships. Augusta was just slightly less important than Trapani as a salt producing center. For Termini, it can easily be conceived that its closeness to Palermo made the presence of a sub consul unnecessary. For all other locations, however, one can only think that the institution of sub consulates there must have been van Achthoven's work⁶¹. Apart from Trapani, where sub consuls were appointed quite often⁶², no subconsul was Flemish and probably none of them was able to speak or understand Dutch⁶³. In June 1634, Francesco Barzellini suddenly died. He had named his brother Giovanni Battista, who at that time was living in Messina, as his only heir, and less than a fortnight after his death van Achthoven duly appointed him as the new sub consul in Palermo. As van Achthoven, he would last as Flemish and German consul in Palermo until 1648.

The consular network which the "Flemish" were able to build up, and which included many more sees than other networks in Sicily, can be taken as a clear proof of the status attained by Dutch navigation in Sicily by the fourth decade of

⁵⁸ ASP, ND I, vv. 3400-14 and 17626-35; ND II, vv. 4318-21, 4324 and 4330-1.

⁵⁹ See Engels, 1997; van Gelder, 2009a. For further information on van Achthoven, see Gozzano, 2011.

⁶⁰ What makes this appointment even more remarkable is that it shortly followed the choice of the sub consul for Trapani and preceded those for the seats of Sciacca, Agrigento and Castellammare.

⁶¹ Van Achthoven's most trusted notary public in Messina was Francesco Testananti, whose production has been entirely lost during World War II. It must be reported that "Flemish" sub consuls were active in Siracusa by 1626 (ASP, ND I, v. 17620, ff. 838v-9v, 20 March 1626) and in Malta by 1629 (ASP, ND II, v. 1091, ff. 1632v-5v, 16 July 1629).

⁶² The sub consulship was filled by Simone Vento, a patrician who also was Dijch's brother-in-law, in 1633-1634, then by Flemish people such as Jan Baptist Nicolais in 1634-1636, Jan Gelcopf in 1636-1637 and Jeroen Gerardi in 1637-1638, who in the following years would be sub consul, alternating, with Giovanni Battista Viali, a Genoese, and Pietro Antonio Galvano.

⁶³ This was also true of the Barzellinis, who needed an interpreter to deal with Dutch masters.

the Seventeenth Century, though official sources still gave a trifling representation of the phenomenon. In 1634-1635, just two *responsali* were issued for wheat transports on board of Flemish ships for a sum total of 5.400 salms, but in the same year the notary public Francesco Sergio drew wheat charter-parties for a sum total of 50.850 salms. Furthermore, Dutch masters were more and more respected and their opinion was asked for a wide range of questions. In March 1635 Gilles Bischof, master of the *Concordia* coming from Amsterdam on her first *Straatvaart*, was asked to settle a disagreement regarding a parcel of wood sold by Baskens although he himself was involved in a dispute with Giacomo Brignone and unable to speak Italian⁶⁴. Yet, in 1635 a single event marked the beginning of a new and even more prosperous time for the Dutch in Sicily. It was France's declaration of war to Spain on 17 May 1635.

4. Supremacy achieved (1635-1648)

Few events appear to have been as momentous for Sicily in the first half of the Seventeenth Century as the entry of France into the Thirty Years' War. The end of the Twelve Years' Truce had certainly been a blow to the Kingdom's finances, but until then war had been fought outside the Mediterranean and the strain had not been too heavy. Money remittances to Northern Italy (mainly through Genoa) grew and became even more expensive for Sicily, because the merchant-bankers who drew bills payable in Genoa, Milan or Florence asked for much higher agios (Trasselli, 1972). Meanwhile harvest failures became more frequent, and revenue from the sale of aristocratic titles dramatically fell. As a consequence, some of the Crown's most prized assets had to be sold as well. New taxes had to be levied, only to be sold to (mostly Genoese) merchant-bankers as the only way of paying for their remittances. Gambling licenses were released, and general pardons became a more and more recurring way to raise further sums.

As regards maritime matters, a new embargo against French merchants and seamen was immediately decreed and, unlike previous ones, was strictly enforced for a long time. Some French traders and masters had been residing in Sicily for years, and had often married Sicilian women – thereby acquiring Sicilian nationality. Others had settled in Malta and could therefore claim to be Maltese⁶⁵. Spanish officials were aware of this and, even if petitions by the Order of St. John forced them to turn a blind eye on the latter, they tried to keep these French under disguise out of Sicily as much as they could⁶⁶. Until then, the French had been the main carriers of most goods between Sicily, the Balearic Islands and mainland Spain: their sudden disappearance left a big hole open to others. The Dutch were not in the best position to exploit it, as medium and small sized vessels took a

⁶⁴ ASP, ND I, v. 17627, ff. 1182v-6r, 3-3-1635, and ff. 1349r-v, 24 March 1635.

⁶⁵ See also Brogini, 2011; 2006.

⁶⁶ ASP, RC, v. 667, f. 194v, 5-25-1637, and v. 669, ff. 230r-v, 23 February 1638.

major share in transports between Sicily and Spain. However, when the French (both merchantmen and men-of-war) resorted to piracy even in Sicilian waters, and most seriously near Sardinia and Corsica, routes to and from Spain became too dangerous for most vessels⁶⁷. After 1637-1638, fewer and fewer Catalan or Balearic vessels were to be found in Sicily and, since Sicilian and Neapolitan merchantmen were in no better position, only the Genoese and the Dutch could profit from this situation. Of course, the latter made much bigger gains than the former. This is also witnessed by insurance premia which, from 1639, became much lower for bigger ships even for longer voyages. After 1635 (and even more since 1637-1638) the Dutch began loading an unprecedentedly wide range of commodities: olive oil, wine, tuna fish, dry fruit, shumac, sugar, liquorice paste and argols⁶⁸. Some of these had been loaded on Dutch ships a few times in 1617-1621, but after the Truce had ended the Dutch had given up all light goods. From 1640 onwards, they also took on freight raw silk for Genoa and Livorno. At first, silk was not more significant than shumac or currants, but by 1642 it ranked as the third most important commodity exported on board Dutch ships⁶⁹. Furthermore, silk (unlike wheat and salt) could be loaded in huge quantities in Palermo. Since silk production was not subject to yearly oscillations so wide as those typical of all grains, this novelty entailed that Dutch ships could be found in Palermo even after bad or middling wheat harvests.

One more factor which boosted Dutch navigation to and from Sicily was the growth of direct trade with Northern Europe, and in particular with Amsterdam. Although this must not be overemphasized, it was an important shift in trade flows. This was not the consequence of war between France and Spain, but rather of the Thirty Years' War raging in Germany, which made overland trade to Genoa and Venice much more difficult. Brignone had made some attempts to export Sicilian wine to Amsterdam back in 1624-1625, but he must not have been successful. By 1631, other merchants active in Palermo began trying shipments of argols⁷⁰ which rapidly became the most important export from Palermo to Amsterdam. By 1634, some Palermo merchants had built strong ties with Amsterdam firms, and some years later Giovanni Battista Bensi, who had been active in Palermo in previous years, established himself in Amsterdam⁷¹. After 1635, exports included liquorice paste, rice, sesame and raw silk, while green and dry fruit was exported from Messina⁷². Salt was exported from Trapani⁷³. Imports were far more important and ranged from lead to cheese, from textiles to books and engravings. This meant that Dutch ships

⁶⁷ ASP, ND I, v. 17630, ff. 944r-5v, 20 February 1638.

⁶⁸ See, for instance, ASP, ND I, v. 17657.

⁶⁹ ASP, ND I, vv. 3406 and 17658; ND II, v. 4324

⁷⁰ ASP, ND I, v. 8125, vv. 1148r-9r, 23 July 1631.

⁷¹ According to Bicci, 1990, he arrived in July 1640 on board *De Hoop*. However, archival evidence suggests that he must have been there since late 1638 at latest (ASP, ND I, v. 17631, ff. 952v-4r, 10 January 1639).

⁷² ASP, ND I, v. 17631, ff. 1664r-6r, 11 April 1639.

⁷³ ASTp, Notai, v. 10721, ff. 248r-9r, 22 March 1635.

calling at Palermo and Trapani would come from Amsterdam or Danzig more frequently than before. Voyages to Sicily must have been coveted by Dutch masters. Cornelis Jacobsz Huc, master of the *Santo Joseph* (2.000 salms deadweight tonnage) struck a deal for a wheat transport to either Livorno and Genoa or a port in Spain, which would have fetched nearly the same sum he had received for his voyage from Texel if to the former destinations, and much more if to the latter⁷⁴. It is no wonder that the number of Dutch masters in Palermo grew dramatically. When silk transports became a regular option, calling at Palermo (or, as in previous years, at Trapani and then travelling to Palermo) became even more advantageous. This oversupply of Dutch ships caused a dramatic fall in freight rates, which by 1642-1625 were about 40% lower than in 1634-1639 for nearly all goods to be shipped from Sicily. In 1644, a Dutch ship was even chartered for the first recorded voyage from Sicily to the New World, with a cargo composed of wine, dry fruit and currants⁷⁵.

Commerce was not the only success of Dutch navigation, nor perhaps the one in which its gains were biggest. As the Mediterranean was a new theater of war, the Spanish Monarchy had an urgent need of transports of troops, as well as of ships to be employed against French and Moorish piracy – or in piracy actions against the Turks⁷⁶. Fighting along the Spanish-French border, and from 1640 onwards the Catalan revolt, also called for supplies of Sicilian barley to Barcelona and Valencia. For all this demands arising from the Crown, the Dutch happened to be the only ones whose services were worth acquiring. As a consequence, Spanish officials soon became important customers of the Dutch, still (in theory) rebels to His Catholic Majesty. At first the Dutch were requested on account of the King⁷⁷, but after some time Viceroys began chartering their ships for private matters as well⁷⁸. The Crown and its officials were usually willing to pay high freight rates. However, they were not always ideal customers, often causing considerable delay in consignments and seldom paying demurrages when required. In those cases, Genoese merchant-bankers could be of help to force the Crown to pay its dues, but dealing with them could also be dangerous. After Willem Cornelisz, master of *L'Angelo Gabriele*, discovered that putting too much emphasis on his requests against Camillo Pallavicini would be at best useless⁷⁹, Dutch masters would take a quieter attitude. Moreover, some of them proved to prefer trade to “war”⁸⁰, i. e. wheat or silk charter-parties to anti-French (or anti-Turk) sea patrolling. Nonetheless, “war” was one more option for Dutch ships coming to Sicily in search of employ, and their masters were highly regarded and well treated. To some extent, notaries perceived this change: all reference to *flamenghi de Dansich* or *de*

⁷⁴ ASP, ND I, v. 3407, ff. 108r-9r, 10-9-1642, and v. 17634, ff. 185r-7v, 14 October 1642.

⁷⁵ ASP, ND I, v. 3409, ff. 277r-8v, 21 November 1644.

⁷⁶ ASP, ND I, v. 17631, ff. 235r-6v, 2 October 1638.

⁷⁷ ASP, ND I, v. 3435, ff. 539r-40r, 26 August 1640. See also Aymard, 1972.

⁷⁸ ASP, ND I, v. 3408, ff. 660r-v, 19 April 1644.

⁷⁹ ASP, ND I, v. 17631, ff. 968r-71v, 12 January 1639.

⁸⁰ ASP, ND II, v. 4348, ff. 607r-8r, 3 June 1645.

Amburgh disappeared. From 1638 onwards Dutch ports and cities were cited again: *Oorn*, *Medeblich*, *Ancusa* (Enkhuizen) and *Astradam* (Amsterdam) above all.

The Dutch were not alone, but competitors from other nationalities were not in a position to challenge their supremacy. The Genoese had smaller vessels, and even when they commanded big ships, these belonged to Flemish ship-owners such as Gaspar de Roemer. The Maltese were too few, and this applied also to the Germans, now labelled *alemanni* or *amburghenses* to distinguish them from the Dutch. The English were no doubt more numerous than in previous years – their growth had indeed started around 1630. However, the Dutch by far outnumbered them. As Sicily had much stronger ties to Genoa than to Livorno, where English presence was stronger⁸¹, it is no wonder that just a few English ships were involved in wheat transports. Salt exports to Venice were a matter for the Dutch only, as besides Reijnst and Heijermans, other merchants settled in the Serenissima such as Jakob Strijcker became interested in that commodity after 1638⁸². Moreover, the English lacked a consular network of their own, and in Palermo and Trapani there still were no English merchants (Pagano, 2007)⁸³. This meant that, unlike the Dutch, they could be harassed from state and local authorities⁸⁴. Furthermore, the Dutch were far more efficient than the English in terms of crew/deadweight tonnage ratio. In May 1644, the English *Campo Verde*, Henry Pavul master, had a crew of 48 for a deadweight tonnage of 1.800 salms, while the Dutch *Tre Valenti di David*, Adriaan Nicola master, was manned by 40 hands for a deadweight tonnage of about 3.000 salms⁸⁵.

When peace between Spain and the United Provinces was signed in 1648, Dutch masters in Palermo or Trapani were not affected by the event. One can even suppose that, as 1646-1650 was a period of ruinous dearth in Sicily, they must have thought of 1642-1645 as a prosperous time. However, even if wheat was missing, there was plenty of salt, raw silk and Spanish officials in want of Dutch ships. Peace had not changed the state of things: The Dutch had won the race for supremacy in Sicilian waters long before the Treaty of Münster.

References

- Abbate, V. (1999). *Porto di Mare 1570-1670: Pittori e Pittura a Palermo tra Memoria e Recupero*. Naples: Electa.
- Ago, R. (1998). *Economia Barocca: Mercato e Istituzioni nella Roma del Seicento*. Rome: Donzelli.
- Aymard, M. (1972). Il Bilancio d'una Lunga Crisi Finanziaria. *Rivista Storica Italiana*, 84(4), 988-1021.

⁸¹ See Engels, 1997, Grendi, 2004 and Ghezzi, 2007.

⁸² ASTp, Notai, v. 10724/a, ff. 220r-1r, 5 May 1640.

⁸³ English merchants are attested in Messina since 1647 at latest (Pagano, 2007). However, available evidence strongly suggests that English masters heavily relied on fellow-countrymen active in Naples up to 1643, if not later.

⁸⁴ ASP, ND I, v. 3406, ff. 613r-4r, 31 August 1642

⁸⁵ ASP, ND I, v. 17598, unnumbered sheets, 2 May 1644 and 11 May 1644. For comparisons with Livorno and Genoa, see Ghezzi 2007 and Felloni 2001.

- Aymard, M. (1976). Il Commercio dei Grani nella Sicilia del Cinquecento. *Archivio Storico per la Sicilia Orientale*, 72(1-3), 7-40
- Barbe, L. (1992). *Don Pedro Tèllez Girón Duc d'Osuna Vice-roi de Sicile 1610-1616*. Grenoble: Erlug.
- Benigno, F. (1982). *Il Porto di Trapani nel Settecento. Rotte, Traffici, Esportazioni (1674-1800)*. Trapani: Camera di Commercio.
- Bicci, A. (1990). Mercanti Italiani ad Amsterdam nel Seicento. *Rivista Storica Italiana*, 102(3), 899-934.
- Braudel, F. (1967). *La Méditerranée et le Monde Méditerranéen à l'Époque de Philippe II*. Paris: Colin.
- Braudel, F., & Romano, R. (1951). *Navires et Marchandises à l'Entrée du Port de Livourne (1547-1611)*. Paris: Colin.
- Brogini, A. (2006). *Malte, Frontière de Chrétienté (1530-1670)*. Rome: École Française de Rome.
- Brogini, A. (2011). "Malte et les Marseillais au début de l'Époque Moderne", in Antonino G. et al. (Eds.), *Studi storici dedicati ad Orazio Cancila*, 7(16). 491-512.
- Brulez, W. (1965). *Marchands Flamands à Venise/1: 1568-1605*. Rome: Institut Historique Belge de Rome.
- Brulez, W. & Devos, G. (1986). *Marchands Flamands à Venise/2: 1606-1621*. Rome: Institut Historique Belge de Rome.
- Cancila, O. (1972). *Aspetti di un Mercato Siciliano. Trapani nei Secoli XVII-XIX*. Rome: Salvatore Sciascia.
- Cancila, O. (1978). Commercio Estero (Secc. XVI-XVIII). In R. Romeo (Ed.), *Storia della Sicilia* (vol VII). Palermo: Società Editrice Storia di Napoli e della Sicilia.
- Cancila, O. (1983). *Baroni e Popolo nella Sicilia del Grano*. Palermo: Palumbo.
- Cancila, O. (2001). El Tráfico del Puerto de Palermo en la Primera Midad del Siglo XVII. In L. A. Ribot Garcia, & L. De Rosa (Eds.), *Naves, Puertos e Itinerarios Maritimos en la Época Moderna*. Madrid: Actas.
- Cingari, G. (1979). *Scilla nel Settecento: «Feluche» e «Venturieri» nel Mediterraneo*, Reggio Calabria: Casa del Libro.
- De Stefano, R. (1982). Il Sale Siciliano e l'Arrendamento dei Quattro Fondaci nella Seconda Metà del XVII Secolo. In G. Motta (Ed.), *Studi Dedicati a Carmelo Trasselli*. Soveria Mannelli: Rubbettino.
- Engels, M. C. (1997). *Interlopers, Seamen and Corsairs. The "Flemish" Community in Livorno and Genoa 1615-1635*. Hilversum: Verloren.
- Felloni, G. (2001). Organización Portuaria, Navegación y Tráfico en Génova: un Sondeo entre las Fuentes de la Edad Moderna. In L. A. Ribor Garcia., & L. De Rosa (Eds.), *Naves, Puertos e Itinerarios Maritimos en la Época Moderna*. Madrid: Actas.
- Galioto, A. (1597). *Relatione dello Scisma Anglicano, e del Glorioso Martirio del B.P.F. Giouanni Foresta Francescano Osseuante: e di Altri Santi Martiri d'Inghilterra nella Persecutione d'Enrico Ottauo. Breuemente Raccolta dal R.P.F. Angelo da Sciacca del Medesimo Ordine*. Palermo: Gio Antonio de Franceschi.
- Gelder, M. van. (2004). Supplying the *Serenissima*. The role of Flemish Merchants in the Venetian Grain Trade during the First Phases of the *Straatvaart*. *International Journal of Maritime History*, 16(2), 39-60.
- Gelder, M. van. (2009a). *Trading Places: The Netherlandish Merchants in Early Modern Venice*. Boston, MA: Brill.
- Gelder, M. van. (2009b). How to Influence Venetian Economic Policy: Collective Petitions of the Netherlandish Merchant Community in the Early Seventeenth Century. *Mediterranean Historical Review*, 24(1), 29-47.
- Ghezzi, R. (2007). *Livorno e il Mondo Islamico nel XVII Secolo (1612-1678)*. Bari: Cacucci
- Gotteri, N. (1969). Gens, Navires et Marchandises à la Douane de Palerme (1600-1605). *Mélanges d'Archeologie et d'Historie*, 81(2), 783-860.
- Gozzano, N. (2011). Mercanti Fiamminghi in Italia nel Seicento: Agenti, Artisti, Consoli. *Bollettino Telematico dell'Arte*, 595. Retrieved 22 February 2011 from <http://www.bta.it/txt/a0/05/bta00595.html>.
- Greene, M. (2002). Beyond the Northern Invasion: The Mediterranean in the Seventeenth Century. *Past and Present*, 174, 42-71.

- Grendi, E. (1968). Traffico Portuale, Naviglio Mercantile e Consolati Genovesi nel Cinquecento. *Rivista Storica Italiana*, 80(3), 593-638.
- Grendi, E. (1971). I Nordici e il Traffico del Porto di Genova: 1590-1666. *Rivista Storica Italiana*, 83(1), 23-71.
- Grendi, E. (2004). Gli Inglesi a Genova (Secoli XVII-XVIII). *Quaderni Storici*, 39(1), 241-278.
- Israel, J. I. (1989). *Dutch Primacy in World Trade 1585-1740*. Oxford: Clarendon.
- Israel, J. I. (1990). *Empires and Entrepôts – The Dutch, the Spanish Monarchy and the Jews, 1585-1713*. London: Hambledon.
- Kellenbenz, H. (1972). Cristoph Furtembach a Genova e il Suo Testamento. *Rivista Storica Italiana*, 84(4), 1102-1113.
- Koenigsberger, H. (1947). English Merchants in Naples and Sicily in the Seventeenth Century. *English Historical Review*, 62(3), 304-326.
- Lentini, R. (2004). Dal Commercio alla Finanza: i Negozianti-banchieri Inglesi nella Sicilia Occidentale tra XVIII e XIX Secolo. *Mediterranea. Ricerche Storiche*, 1(2), 105-122.
- Martelli, F., & Galasso, C. (2007). *Istruzioni agli Ambasciatori e Inviati Medicei in Spagna e nell' "Italia Spagnola" (1536-1648)/II (1587-1648)*. Rome: Ministero per i Beni e le Attività Culturali, Direzione Generale per gli Archivi.
- Pagano de Divitiis, G. (1990). *Mercanti Inglesi nell'Italia del Seicento. Navi, Traffici, Egemonie*. Venice: Marsilio.
- Pagano de Divitiis, G. (1996). Grano del Nord e Carestie in Italia tra Fine Cinquecento e Inizio Seicento. *Miscellanea di Studi Storici*, 9. Soveria Mannelli: Rubettino.
- Pagano de Divitiis, G. (2007). An English Merchant in the Mediterranean: Arthur Penington (1621-1677). In C. Vassallo & M. D'Angelo (Eds.), *Anglo-Saxons in the Mediterranean: Commerce, Politics and Ideas (XVII-XX Centuries)*. Malta: Malta University Press.
- Ruspio, F. (2007). *La Nazione Portoghese: Ebrei Ponentini e Nuovi Cristiani a Venezia*. Turin: Zamorani.
- Simoncini, G. (Ed.), (1997). *Sopra i Porti di Mare. III: Sicilia e Malta*. Florence: Leo S. Olschki.
- Tenenti, A., & B. (1985). *Il Prezzo del Rischio: l'Assicurazione Mediterranea Vista da Ragusa (1563-1591)*. Rome: Jouvence.
- Tihon, C. (1938). Un Consulat Belge à Palerme au XVIIème Siècle. *Bulletin de l'Institut Historique Belge de Rome*, 19, 77-82.
- Trasselli, C. (1962). Les Sources d'Archives pour l'Histoire du Trafic Maritime en Sicilie. In Michel M. et al (Eds.), *Les Sources de l'Histoire Maritime en Europe, du Moyen Âge au XVIIIème Siècle*. Paris: S.E.V.P.E.N.
- Trasselli, C. (1967). Sul Naviglio Nordico in Sicilia nel XVII Secolo. In Juan M. de M. (Ed.), *Homenaje a Jaime Vicens Vives/2*. Barcelona: Universidad de Barcelona, Facultad de Filosofia y Letras.
- Trasselli, C. (1978). Mercanti Forestieri in Sicilia nell'Età Moderna. In R. Romeo (Ed.), *Storia della Sicilia/VII*. Palermo: Società Editrice Storia di Napoli e della Sicilia.
- Vigiano, V. (2004). *L'Esercizio della Politica: la Città di Palermo nel Cinquecento*. Rome: Viella.
- de Vries, J., van der Woude, A. (1997). *The First Modern Economy: Success, Failure and Perseverance of the Dutch Economy, 1500-1800*. Cambridge: Cambridge University Press.

Archives

- ASP. Archivio di Stato di Palermo.
MP. Fondo Mastro Portulano.
ND. (I, II). Fondo Notai Defunti (stanza I, II).
RC. Fondo Real Cancelleria.
RS. Fondo Real Segreteria.
- AST. Archivio di Stato di Torino.
- ASTp. Archivio di Stato di Trapani.
Notai. Notai del distretto di Trapani.

Özlem ÇAYKENT – Luca ZAVAGNO
Editors

This edited volume resulted from an interdisciplinary effort to examine the diverse social, political, economic and religious aspects engrossing the matrix of communications across the Mediterranean basin from the early Medieval to the Modern era. It includes papers on different aspects of the commercial dynamics- from historical to archaeological, from political to sociological- and it aims at illustrating the important interactive role trade played within different Mediterranean societies stressing the continuity emanated from people (traders and other actors) and used spaces (trade routes) from the seventh to the seventeenth century.

Divided into two parts, Medieval and Modern Mediterranean, the book brings together a constellation of articles that explore the politics and economics of trade across the Medieval and Modern Mediterranean with an emphasis on the tangible and intangible aspects of commercial relationship across political, religious and cultural frontiers of the Great Sea.

978-88-99662-02-8



9 788899 662028